

McLaren Artura eMotor Cooling Pump

This document is uncontrolled when printed. Before use, check the Knowledge Base within the McLaren Retailer Portal to verify that this is the current version.

Document Information

Location: Powertrain / Electrical

Topic: E-motor cooling pump LIN fault

Condition: E-motor overheating faults/cooling pump no function

Diagnostic Trouble Codes: N/A

Measure

If there are e-motor cooling faults stored or e-motor cooling issues

1. Manually confirm cooling pump function by listening/feeling for pump noise/vibration during activation.
2. If no pump function is determined check for any DTC's for the rear parking sensors. If rear sensor faults are present please troubleshoot these first as they can affect cooling pump function as they are on the same LIN bus (see diagram below).

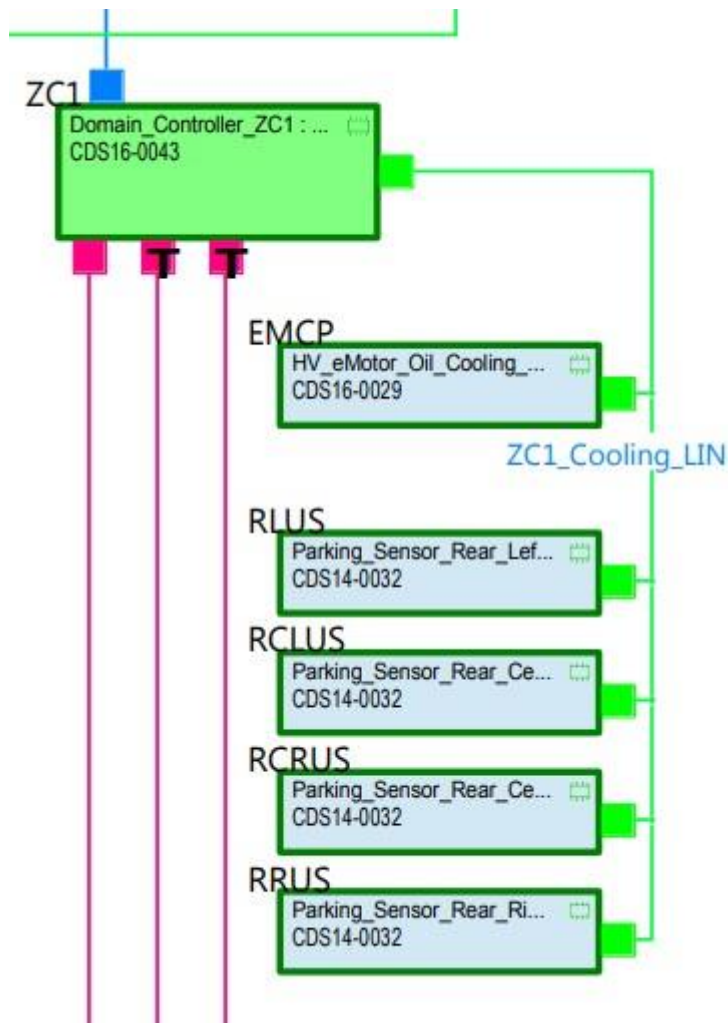

Parts Information

N/A

Attachments

N/A

This document is uncontrolled when printed. Before use, check the Knowledge Base within the McLaren Retailer Portal to verify that this is the current version.

RESTRICTED