

**WPS1 - Checking Pressure Sensors and Replacing them if Necessary (Workshop Campaign)**

**Important:** **CRITICAL WARNING** -This campaign includes steps where control unit(s) in the vehicle will be programmed with the PIWIS Tester. The vehicle voltage must be maintained between 13.5 volts and 14.5 volts during this programming. Failure to maintain this voltage could result in damaged control unit(s). Damage caused by inadequate voltage during programming is not a warrantable defect. The technician must verify the actual vehicle voltage in the PIWIS Tester before starting the campaign and also document the actual voltage on the repair order.

**Change overview:**

Release	Date	Change
1	07/26/2024	• First publication
2	08/10/2024	• Update of TUs

**Model Year:** As of 2020 up to 2023

**Vehicle Type:** Panamera Turbo S E-Hybrid (971)

**Concerns:** Air conditioning system pressure sensors

**Cause:** Due to a manufacturing error at the supplier, pressure sensors for the refrigerant circuit that do not meet the required specifications were installed in the affected vehicles.

The failure of one or both pressure sensors in the refrigerant circuit therefore cannot be ruled out over the lifetime of the vehicle. As a result, there is a possibility that the air conditioning and battery cooling system are not functioning properly.

This can lead to an increased temperature of the high-voltage battery.

**Action:** Check pressure sensors and replace them if necessary.

**Affected Vehicles:** Only vehicles assigned to the campaign (see also PCSS Vehicle Information).

## Installation

## Position:

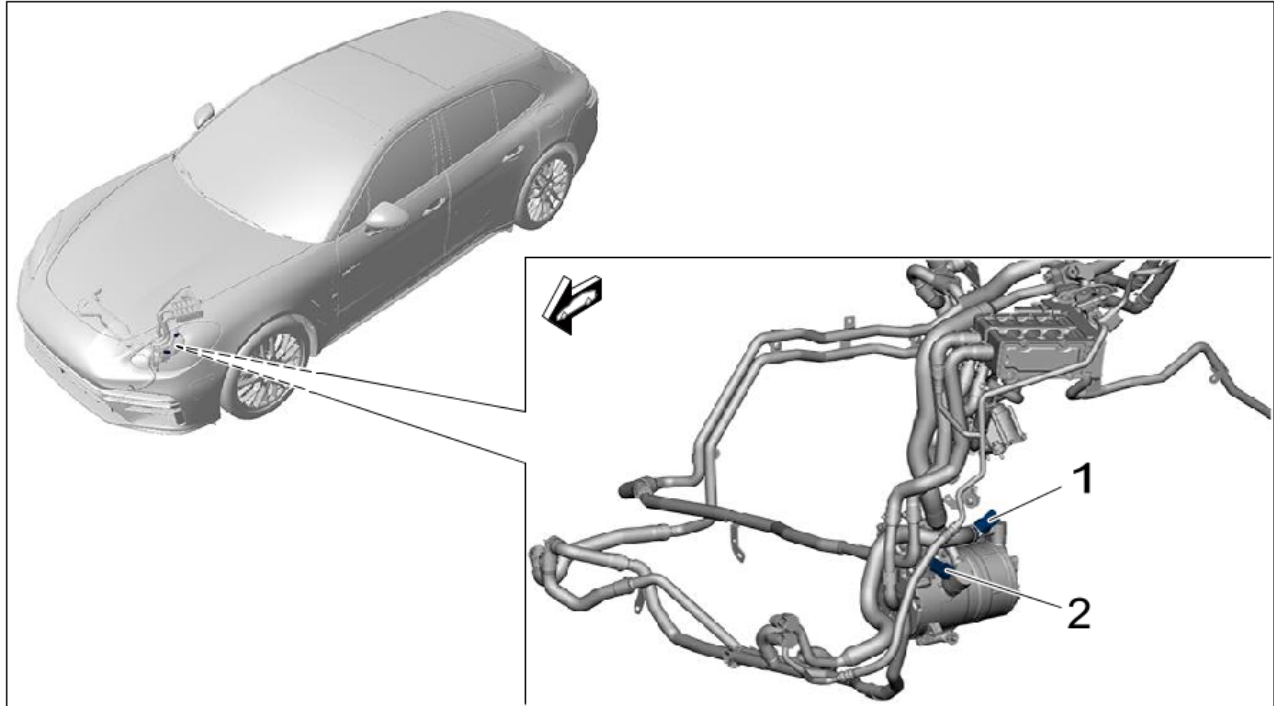

*Installation position of pressure sensors*

- 1 – Pressure sensor (PT1) on high-pressure side **(check and replace if necessary)**
- 2 – Pressure sensor (PT2) on low-pressure side **(check and replace if necessary)**

### Required parts and materials

The **part numbers** of the **parts and materials required** for the respective vehicle can be seen in the **assigned scope**. For an overview of the campaign scopes, see: ⇒ *Technical Information 'Warranty processing'*.

For materials (lubricants) required for carrying out the action, see the corresponding Workshop Manual in PCSS. These lubricants are usually available in the Porsche Center.

### Required tools

## Tools:

**Tools required for testing pressure sensors:**

- Torque wrench, 2-10 Nm (1.5-7.5 ftlb.), e.g., **V.A.G 1783 - torque wrench, 2-10 Nm (1.5-7.5 ftlb.)**
- Torque wrench, 6-50 Nm (4.5-37 ftlb.), e.g. **V.A.G 1331A - torque wrench, 6-50 Nm (4.5-37 ftlb.)**
- Torque wrench, 40-200 Nm (30-148 ftlb.) e.g., **V.A.G 1332A - torque wrench, 40-200 Nm (30-148 ftlb.)**

- Threaded bolts for installing wheel
- **VAS 6883A - Insulated tool set**
- **T40262 - T40262 - Locking cap**
- **VAS 6410 - Contact surface cleaning set**
- **VAS 6558/9-6A - High-voltage test adapter**
- **VAS 6558A - High-voltage measuring module**
- **WE 1383 - Hybrid warning signs**

**Tools additionally required for replacement of pressure sensor (PT1) and/or pressure sensor (PT2)**

- Battery charger with a current rating of **at least 90 A**, e.g., **VAS 5908 - battery charger 90 A**
- **P90999 - PIWIS Tester 4**
- Socket wrench, a/f 24, e.g., **T40363 - socket wrench, a/f 24**
- **Air conditioning servicing equipment** for refrigerant **R134a** or **R1234yf** recommended by Porsche (depending on the refrigerant used). For recommended service equipment, see the Workshop Equipment and Special Tools Manual.

### Preparatory work

- Work Procedure: 1 Deactivation of high-voltage system.  
 ⇒ *Workshop Manual '2X00IN Deactivating/starting high-voltage system'*
- 2 Remove the front left wheel.  
 ⇒ *Workshop Manual '440519 Removing and installing wheel'*
- 3 Remove the front section of the wheel housing liner.  
 For procedure, see:  
 ⇒ *Workshop Manual '505619 Remove and install the wheel housing liner front'*
- 4 Remove the front air guide at the left side (behind charge-air cooler).  
 For procedure, see:  
 ⇒ *Workshop Manual '211019 Removing and installing front air guide at the side (behind charge-air cooler)'*

- 5 Loosen the protective plate on air-conditioning compressor ⇒ *Loosening protective plate on air-conditioning compressor -1-*.
  - 5.1 Unscrew nut ⇒ *Loosening protective plate on air-conditioning compressor -3-*.
  - 5.2 Only loosen screws ⇒ *Loosening protective plate on air-conditioning compressor -2-*.
  - 5.3 Turn protective plate ⇒ *Loosening protective plate on air-conditioning compressor -1-* downwards in ⇒ *Loosening protective plate on air-conditioning compressor -Arrow direction-* until the pressure sensor (PT2) is accessible.

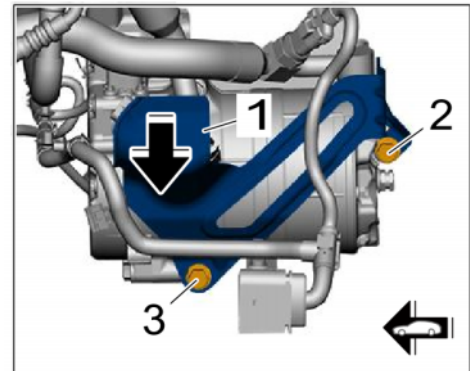

*Loosening protective plate on air-conditioning compressor*

### Checking pressure sensors and replacing them if necessary

Work  
Procedure:



#### Information

The installed pressure sensors must be checked using the spare part number and the production date.

All pressure sensors with spare part number 4M0.959.603.**C** are **not OK** and must be **replaced**.

Pressure sensors with spare part number 4M0.959.603.**E** must also be checked from the applied production date.

Pressure sensors with spare part number 4M0.959.603.**E** and applied production date:

- **up to** \_41921 are **not OK** and must be replaced.
- **from** \_42921 are **OK** and do **not** need to be replaced.



*New type of pressure sensor*

- 1 – Spare part index
- 2 – Production date from \_42921 (S / D / CW / YY · Shift / Weekday / Calendar Week / Year). Shown in the image: 1st place not relevant / weekday **6** / calendar week **08** / year**2022**

- 1 Check whether **pressure sensor PT1** corresponds to the new component status.

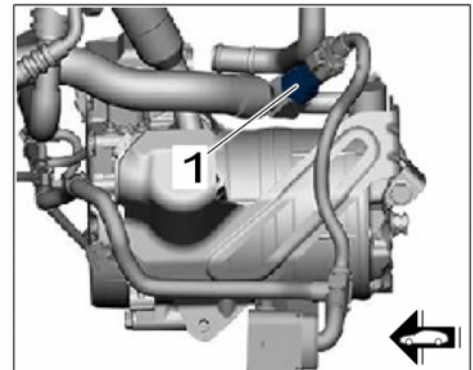

*Checking pressure sensor PT1*

- 2 Check whether **pressure sensor PT2** corresponds to the new component status.

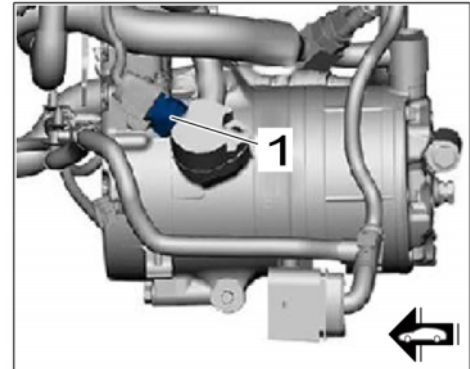

Checking pressure sensor PT2

Assessment		Action
(x)	Pressure sensor with spare part number 4M0.959.603.C	Pressure sensors with spare part index <b>C</b> are <b>not OK</b> and must be replaced.  Replace the relevant pressure sensors. ⇒ Continue with Step 3 ⇒  [ Scope 14 to Scope 16]
(x)	Pressure sensor with spare part number 4M0.959.603.E and production date <b>up to</b> _41921	Pressure sensor is <b>not OK</b> due to production date (up to _41921) and must be replaced.  Replace the relevant pressure sensors. ⇒ Continue with Step 3 ⇒  [ Scope 14 to Scope 16]
(✓)	Pressure sensor with spare part number 4M0.959.603.E and production date <b>from</b> _42921	Pressure sensor is <b>OK</b> due to spare part index E <b>and</b> production date (from _42921) and does <b>not</b> have to be replaced.  <b>End of action.</b> Continue with ⇒ <i>Technical Information '211019 follow-up actions'</i>  [ Scope 13]



**Information**

When replacing pressure sensors, it is essential to ensure that the pressure sensors have the same spare part index. If one of the pressure sensors has a different spare part index, the corresponding pressure sensor must also be replaced. The spare part index is visible on the pressure sensor. (Example 4M0.959.603.E)

- 1 – Spare part index for pressure sensor
- 3 Replace pressure sensors **with old component status**.  
For procedure, see:  
⇒ *Workshop Manual '878319 Removing and installing pressure sensor (PT1 and PT2)'*



*Spare part index for pressure sensor*

**Follow-up actions**

- 1 Fasten the protective plate on air-conditioning compressor ⇒ *Fastening protective plate on air-conditioning compressor -1-*.
  - 1.1 Turn protective plate ⇒ *Fastening protective plate on air-conditioning compressor -1-* upwards in ⇒ *Fastening protective plate on air-conditioning compressor -Arrow direction-* and align it with the stud on nut ⇒ *Fastening protective plate on air-conditioning compressor -3-*.
  - 1.2 Tighten screw ⇒ *Fastening protective plate on air-conditioning compressor -2-* on the **with tightening torque 20 Nm (14.8 ftlb.)**.
  - 1.3 Install nut ⇒ *Fastening protective plate on air-conditioning compressor -3-* and tighten the **with tightening torque 20 Nm (14.8 ftlb.)**.
- 2 Install the front air guide at the left side (behind charge-air cooler).  
For procedure, see: ⇒ *Workshop Manual '211019 Removing and installing front air guide at the side (behind charge-air cooler)'*

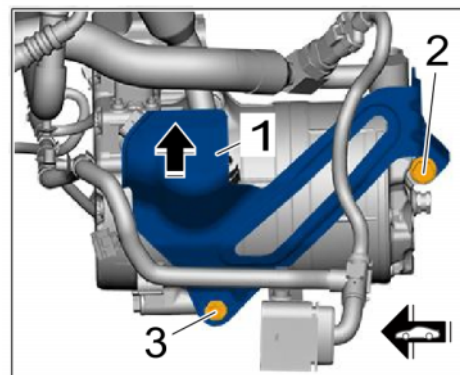

*Fastening protective plate on air-conditioning compressor*

- 3 Install the front section of the wheel housing liner.  
For procedure, see: ⇒ *Workshop Manual '505619 Remove and install the wheel housing liner front'*
- 4 Install the front left wheel. ⇒ *Workshop Manual '440519 Removing and installing wheel'*
- 5 Start the high-voltage system.  
⇒ *Workshop Manual '2X00IN Deactivating/starting high-voltage system'*
- 6 Enter the campaign in the Warranty and Maintenance booklet.

### Warranty processing

Scope 1 to  
Scope 12: **Not relevant for this vehicle type.**

Scope 13: **Checking pressure sensors**

#### Labor time:

Checking pressure sensors

Labor time: **113 TU**

Includes:

- Deactivating/starting high-voltage system
- Removing and installing front left wheel
- Removing and installing front section of front wheel housing liner
- Removing and installing front air guide at the left side (behind charge-air cooler)
- Loosening and fastening protective plate on air-conditioning compressor

⇒ **Damage number WPS1 066 000 1**

Scope 14: **Checking pressure sensors and replacing pressure sensor PT1**

#### Labor time:

Checking pressure sensors and replacing pressure sensor PT1

Labor time: **225 TU**

Includes:

- Deactivating/starting high-voltage system
- Removing and installing front left wheel
- Removing and installing front section of front wheel housing liner
- Removing and installing front air guide at the left side (behind charge-air cooler)
- Loosening and fastening protective plate on air-conditioning compressor
- Draining and filling refrigerant

Connecting and disconnecting battery charger  
 Connecting and disconnecting PIWIS Tester  
 Teaching pressure sensor using PIWIS Tester

**Required parts:**

Part No.	Designation – Location	Quantity
V04015959	Pressure sensor – Air-conditioning system	1 piece

**Required materials** (usually already available in the Porsche Center):

WPS10000001 <sup>1)</sup>	Refrigerant oil SP-A2 (250 ml/ 8.45 fl oz container)	1 piece
WPS10000002 <sup>2)</sup>	Refrigerant R134a	1 piece
<b>or</b>		
WPS10000003 <sup>3)</sup>	Refrigerant R1234yf	1 piece

<sup>1)</sup> For warranty processing, enter the corresponding part number with the designation 'Refrigerant SP-A2' **as an external component** in the warranty claim; maximum cost: \$6.51

<sup>2)</sup> For warranty processing, enter the corresponding part number with the designation 'Refrigerant R134a' **as an external component** in the warranty claim; maximum cost: \$5.42

<sup>3)</sup> For warranty processing, enter the corresponding part number with the designation 'Refrigerant R1234yf' **as an external component** in the warranty claim; maximum cost: \$16.26

⇒ **Damage number WPS1 066 000 2**

Scope 15:

**Checking pressure sensors and replacing pressure sensor PT2**

**Labor time:**

Checking pressure sensors and replacing pressure sensor PT2 Labor time: **222 TU**

- Includes:
- Deactivating/starting high-voltage system
  - Removing and installing front left wheel
  - Removing and installing front section of front wheel housing liner
  - Removing and installing front air guide at the left side (behind charge-air cooler)
  - Loosening and fastening protective plate on air-conditioning compressor
  - Draining and filling refrigerant
  - Connecting and disconnecting battery charger
  - Connecting and disconnecting PIWIS Tester

Teaching pressure sensor using PIWIS Tester

**Required parts:**

Part No.	Designation – Location	Quantity
V04015959	Pressure sensor – Air-conditioning system	1 piece

**Required materials** (usually already available in the Porsche Center):

WPS10000001 <sup>1)</sup>	Refrigerant oil SP-A2 (250 ml/ 8.45 fl oz container)	1 piece
WPS10000002 <sup>2)</sup>	Refrigerant R134a	1 piece
<b>or</b>		
WPS10000003 <sup>3)</sup>	Refrigerant R1234yf	1 piece

<sup>1)</sup> For warranty processing, enter the corresponding part number with the designation 'Refrigerant SP-A2' **as an external component** in the warranty claim; maximum cost: \$6.51

<sup>2)</sup> For warranty processing, enter the corresponding part number with the designation 'Refrigerant R134a' **as an external component** in the warranty claim; maximum cost: \$5.42

<sup>3)</sup> For warranty processing, enter the corresponding part number with the designation 'Refrigerant R1234yf' **as an external component** in the warranty claim; maximum cost: \$16.26

⇒ **Damage number WPS1 066 000 2**

Scope 16:

**Checking pressure sensors and replacing pressure sensor PT1 and pressure sensor PT2**

**Labor time:**

Checking pressure sensors and replacing pressure sensor PT1 and pressure sensor PT2 Labor time: **251 TU**

Includes:

- Deactivating/starting high-voltage system
- Removing and installing front left wheel
- Removing and installing front section of front wheel housing liner
- Removing and installing front air guide at the left side (behind charge-air cooler)
- Loosening and fastening protective plate on air-conditioning compressor
- Draining and filling refrigerant
- Connecting and disconnecting battery charger
- Connecting and disconnecting PIWIS Tester

Teaching pressure sensor using PIWIS Tester

**Required parts:**

Part No.	Designation – Location	Quantity
V04015959	Pressure sensor – Air-conditioning system	2 pieces

**Required materials** (usually already available in the Porsche Center):

WPS10000001 <sup>1)</sup>	Refrigerant oil SP-A2 (250 ml/ 8.45 fl oz container)	1 piece
WPS10000002 <sup>2)</sup>	Refrigerant R134a	1 piece
<b>or</b>		
WPS10000003 <sup>3)</sup>	Refrigerant R1234yf	1 piece

<sup>1)</sup> For warranty processing, enter the corresponding part number with the designation 'Refrigerant SP-A2' **as an external component** in the warranty claim; maximum cost: \$6.51

<sup>2)</sup> For warranty processing, enter the corresponding part number with the designation 'Refrigerant R134a' **as an external component** in the warranty claim; maximum cost: \$5.42

<sup>3)</sup> For warranty processing, enter the corresponding part number with the designation 'Refrigerant R1234yf' **as an external component** in the warranty claim; maximum cost: \$16.26

⇒ **Damage number WPS1 066 000 2**

**Important Notice:** Technical Bulletins issued by Porsche Cars North America, Inc. are intended only for use by professional automotive technicians who have attended Porsche service training courses. They are written to inform those technicians of conditions that may occur on some Porsche vehicles, or to provide information that could assist in the proper servicing of a vehicle. Porsche special tools may be necessary in order to perform certain operations identified in these bulletins. Use of tools and procedures other than those Porsche recommends in these bulletins may be detrimental to the safe operation of your vehicle, and may endanger the people working on it. Properly trained Porsche technicians have the equipment, tools, safety instructions, and know-how to do the job properly and safely. Part numbers listed in these bulletins are for reference only. The work procedures updated electronically in the Porsche PIWIS diagnostic and testing device take precedence and, in the event of a discrepancy, the work procedures in the PIWIS Tester are the ones that must be followed.

© 2024 Porsche Cars North America, Inc.