

WPS1 - Checking Pressure Sensors and Replacing them if Necessary (Workshop Campaign)

Important: **CRITICAL WARNING** -This campaign includes steps where control unit(s) in the vehicle will be programmed with the PIWIS Tester. The vehicle voltage must be maintained between 13.5 volts and 14.5 volts during this programming. Failure to maintain this voltage could result in damaged control unit(s). Damage caused by inadequate voltage during programming is not a warrantable defect. The technician must verify the actual vehicle voltage in the PIWIS Tester before starting the campaign and also document the actual voltage on the repair order.

Change overview:

Release	Date	Change
1	07/26/2024	• First publication
2	08/10/2024	• Update of TUs

Model Year: As of 2020 up to 2023

Vehicle Type: Cayenne Turbo S E-Hybrid (9YA / 9YB)

Concerns: Air conditioning system pressure sensors

Cause: Due to a manufacturing error at the supplier, pressure sensors for the refrigerant circuit that do not meet the required specifications were installed in the affected vehicles.

The failure of one or both pressure sensors in the refrigerant circuit therefore cannot be ruled out over the lifetime of the vehicle. As a result, there is a possibility that the air conditioning and battery cooling system are not functioning properly.

This can lead to an increased temperature of the high-voltage battery.

Action: Check pressure sensors and replace them if necessary.

Affected Vehicles: Only vehicles assigned to the campaign (see also PCSS Vehicle Information).

Installation

Position:

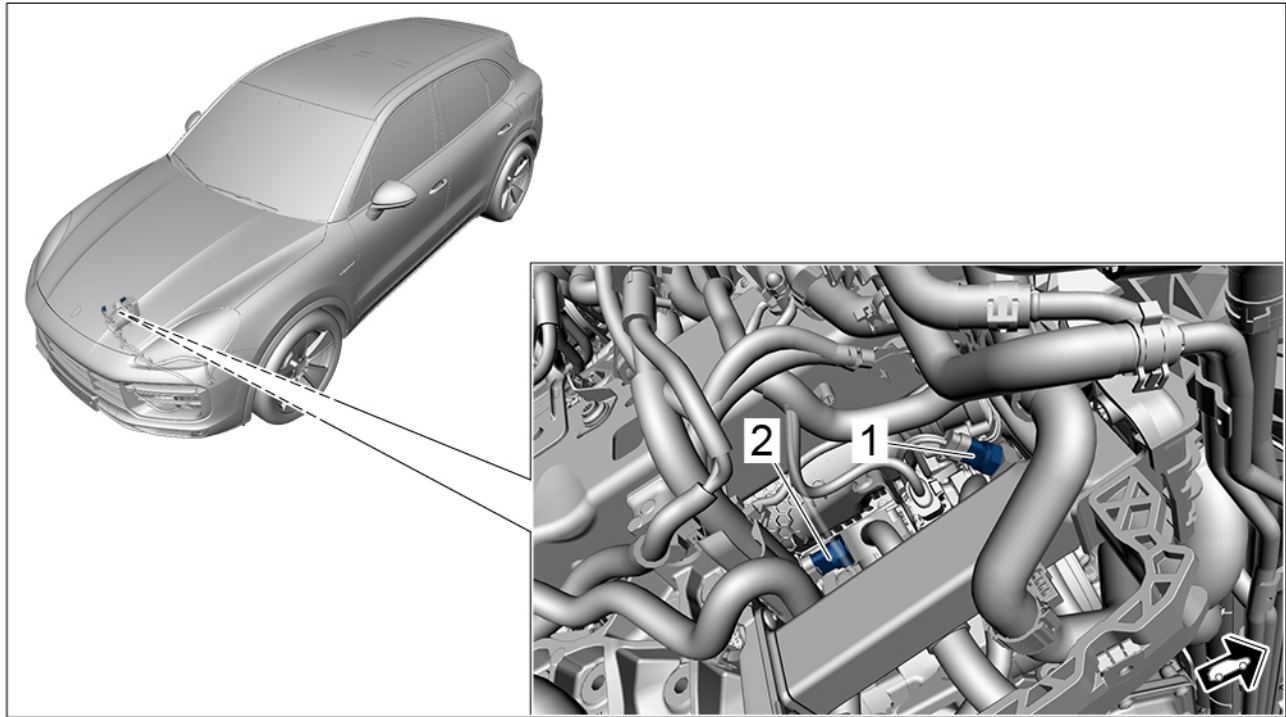

Installation position of pressure sensors

- 1 – Pressure sensor (PT1) on high-pressure side (**check and replace if necessary**)
- 2 – Pressure sensor (PT2) on low-pressure side (**check and replace if necessary**)

Required parts and materials

The **part numbers** of the **parts and materials required** for the respective vehicle can be seen in the **assigned scope**. For an overview of the campaign scopes, see: ⇒ *Technical Information 'Warranty processing'*.

For materials (lubricants) required for carrying out the action, see the corresponding Workshop Manual in PCSS. These lubricants are usually available in the Porsche Center.

Required tools

Tools: **Tools required for testing pressure sensors:**

- Torque wrench, 2-10 Nm (1.5-7.5 ftlb.), e.g., **V.A.G 1783 - torque wrench, 2-10 Nm (1.5-7.5 ftlb.)**
- Torque wrench, 6-50 Nm (4.5-37 ftlb.), e.g. **V.A.G 1331A - torque wrench, 6-50 Nm (4.5-37 ftlb.)**

- Torque wrench, 40-200 Nm (30-148 ftlb.) e.g., **V.A.G 1332A - torque wrench, 40-200 Nm (30-148 ftlb.)**
- Threaded bolts for installing wheel

Tools additionally required for replacement of pressure sensor (PT1) and/or pressure sensor (PT2)

- Battery charger with a current rating of **at least 90 A**, e.g., **VAS 5908 - battery charger 90 A**
- **P90999 - PIWIS Tester 4**
- **VAS 6935 - Pole terminal puller**
- Socket wrench, a/f 24, e.g., **T40363 - socket wrench, a/f 24**
- **Air conditioning servicing equipment** for refrigerant **R134a** or **R1234yf** recommended by Porsche (depending on the refrigerant used). For recommended service equipment, see the Workshop Equipment and Special Tools Manual.

Preparatory work

- Work Procedure: 1 Remove the front underbody cover.
⇒ *Workshop Manual '519219 Removing and installing front underbody cover'*
- 2 Remove the front right wheel housing liner.
⇒ *Workshop Manual '505619 Remove and install the wheel housing liner front'*
- 3 Remove lower moulded hose at the bottom.
For procedure, see:
⇒ *Workshop Manual '213919 Removing and installing moulded hose (V8 Biturbo)'*
- 4 Disconnect coolant line ⇒ *Coolant line on longitudinal member -1-* from longitudinal member.
- 4.1 Open line clip ⇒ *Coolant line on longitudinal member -2-*.
- 4.2 Remove coolant line ⇒ *Coolant line on longitudinal member -1-*.
- 5 Remove longitudinal member ⇒ *Removing longitudinal member (shown on left side of vehicle) -1-* at the right.

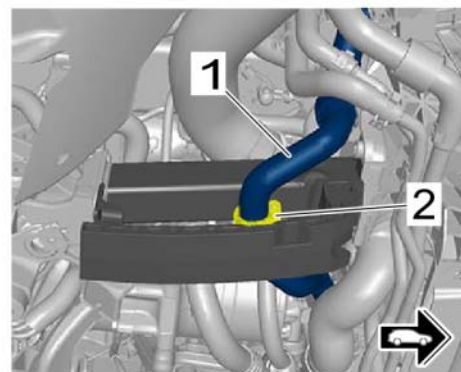

Coolant line on longitudinal member

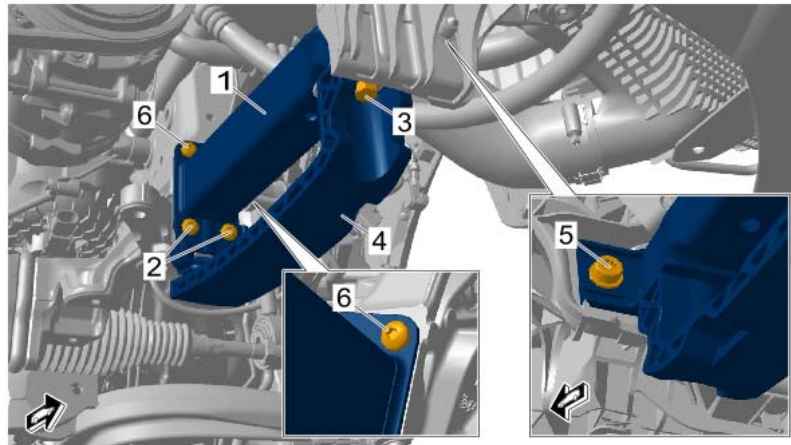

Removing longitudinal member (shown on left side of vehicle)

- 5.1 Unscrew screws ⇒ *Removing longitudinal member (shown on left side of vehicle)-2-*.
- 5.2 Unscrew screw ⇒ *Removing longitudinal member (shown on left side of vehicle)-3-* and remove slide ⇒ *Removing longitudinal member (shown on left side of vehicle)-4-*.
- 5.3 Unscrew screw securing lock support panel to longitudinal member ⇒ *Removing longitudinal member (shown on left side of vehicle)-5-*.
- 5.4 Unscrew screws ⇒ *Removing longitudinal member (shown on left side of vehicle)-6-* and remove longitudinal member ⇒ *Removing longitudinal member (shown on left side of vehicle)-1-*.

Checking pressure sensors and replacing them if necessary

Work
Procedure:



Information

The installed pressure sensors must be checked using the spare part number and the production date.

All pressure sensors with spare part number 4M0.959.603.**C** are **not OK** and must be **replaced**.

Pressure sensors with spare part number 4M0.959.603.**E** must also be checked from the applied production date.

Pressure sensors with spare part number 4M0.959.603.**E** and applied production date:

- **up to** _41921 are **not OK** and must be replaced.
- **from** _42921 are **OK** and do **not** need to be replaced.



New type of pressure sensor

- 1 – Spare part index
- 2 – Production date from _42921 (S / D / CW / YY · Shift / Weekday / Calendar Week / Year). Shown in the image: 1st place not relevant / weekday **6** / calendar week **08** / year**2022**

- 1 Check whether **pressure sensor PT1** ⇒ *Checking pressure sensor PT1 and pressure sensor PT2 -1-* and **pressure sensor PT2** correspond to ⇒ *Checking pressure sensor PT1 and pressure sensor PT2 -2-* the new component status.

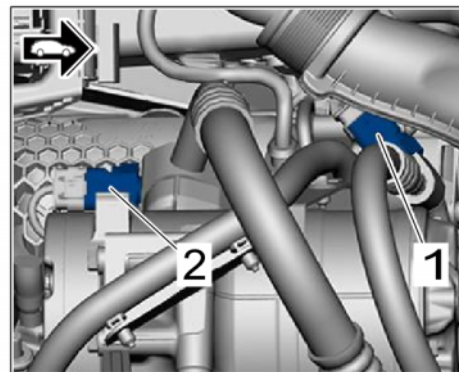

Checking pressure sensor PT1 and pressure sensor PT2

	Assessment	Action
(X)	Pressure sensor with spare part number 4M0.959.603.C	Pressure sensors with spare part index C are not OK and must be replaced. Replace the relevant pressure sensors. ⇒ Continue with Step 2 ⇒ [Scope 6 to Scope 8]
(X)	Pressure sensor with spare part number 4M0.959.603.E and production date up to _41921	Pressure sensor is not OK due to production date (up to _41921) and must be replaced. Replace the relevant pressure sensors. ⇒ Continue with Step 2 ⇒ [Scope 6 to Scope 8]
(✓)	Pressure sensor with spare part number 4M0.959.603.E and production date from _42921	Pressure sensor is OK due to spare part index E and production date (from _42921) and does not have to be replaced. End of action. Continue with ⇒ <i>Technical Information '213919 follow-up actions'</i> [Scope 2]



Information

When replacing pressure sensors, it is essential to ensure that the pressure sensors have the same spare part index. If one of the pressure sensors has a different index, the corresponding pressure sensor must also be replaced. The index is visible on the pressure sensor.

- 1 – Spare part index for pressure sensor
- 2 Replace pressure sensors **with old component status**.
For procedure, see:
⇒ *Workshop Manual '878319 Removing and installing pressure sensor (PT1 and PT2)'*



Spare part index for pressure sensor

Follow-up actions

- 1 Install longitudinal member ⇒ -1- at the right.

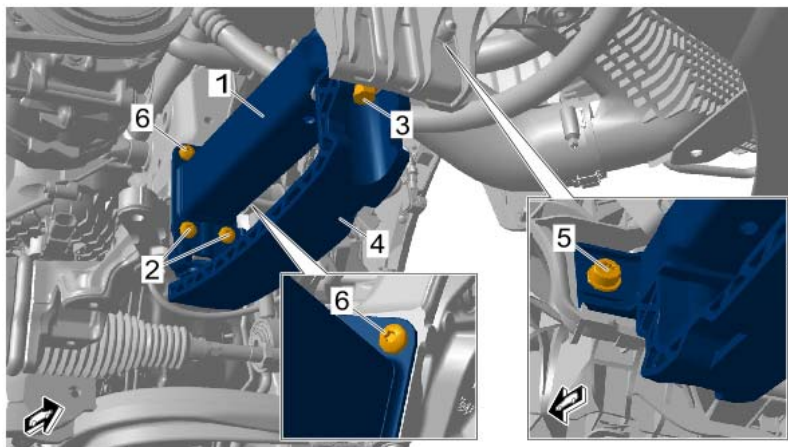

Longitudinal member

- 1.1 Position longitudinal member ⇒ -1-.
- 1.2 Screw in and tighten screws ⇒ -6- for the **with tightening torque 10 Nm (7.4 ftlb.)**.
- 1.3 Screw in and tighten screws ⇒ -5- for the **with tightening torque 23 Nm (17 ftlb.)**.
- 1.4 Position slide ⇒ -4-.
- 1.5 Screw in and tighten screws ⇒ -3- for the **with tightening torque 25 Nm (18.4 ftlb.)**.
- 1.6 Screw in and tighten screws ⇒ -2- for the **with tightening torque 10 Nm (7.4 ftlb.)**.

- 2 Tighten coolant line ⇒ *Tightening coolant line on longitudinal member -1-* on longitudinal member.

- 2.1 Position coolant line ⇒ *Tightening coolant line on longitudinal member -1-* in line clip.
- 2.2 Close line clip ⇒ *Tightening coolant line on longitudinal member -2-*.

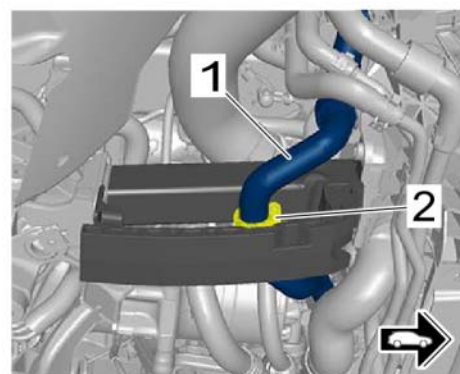

Tightening coolant line on longitudinal member

- 3 Install moulded hose.
⇒ *Workshop Manual '213919 Removing and installing moulded hose (V8 Biturbo)'*
- 4 Install the front right wheel housing liner.
⇒ *Workshop Manual '505619 Remove and install the wheel housing liner front'*
- 5 Install the front underbody cover.
⇒ *Workshop Manual '519219 Removing and installing front underbody cover'*
- 6 Enter the campaign in the Warranty and Maintenance booklet.

Warranty processing**Information**

The specified labor times were determined specifically for carrying out this campaign and include all necessary preliminary and subsequent rework. The labor times may differ from the labor times published in the Labor Operation List in PCSS.

**Information**

Depending on usage and environmental influences, approx. 10% of the refrigerant can escape from the refrigerant circuit per year. This corresponds to 66 g for refrigerant R134a and 70 g for refrigerant R1234yf during a service life of two years.

If significantly more refrigerant has escaped the refrigerant circuit, the refrigerant circuit must be checked and the cause for the refrigerant loss eliminated. This work **cannot** be invoiced under the workshop campaign number.

Scope 1: **Not relevant for this vehicle type.**

Scope 2: **Checking pressure sensors**

Labor time:

Checking pressure sensors

Labor time: **173 TU**

Includes:

- Removing and installing front underbody cover
- Removing and installing front right wheel housing liner
- Removing and installing moulded hose at the bottom
- Loosening and fastening coolant line
- Loosening and fastening longitudinal member with sliding piece

Required parts:

Part No.	Designation – Location	Quantity
PAF00072900	M8 x 20 hexagon socket head bolt – Front underbody cover	3 pieces

⇒ **Damage number WPS1 066 000 1**

Scope 3,
Scope 4,
Scope 5:

Not relevant for this vehicle type.

Scope 6:

Checking pressure sensors and replacing pressure sensor PT1

Labor time:		
Checking pressure sensors and replacing pressure sensor PT1		Labor time: 336 TU
Includes:	<ul style="list-style-type: none"> Removing and installing front underbody cover Removing and installing front right wheel housing liner Removing and installing moulded hose at the bottom Loosening and fastening coolant line Loosening and fastening longitudinal member with sliding piece Draining and filling refrigerant Connecting and disconnecting battery charger Connecting and disconnecting PIWIS Tester Teaching pressure sensor using PIWIS Tester 	
Required parts:		
Part No.	Designation – Location	Quantity
V04015959	Pressure sensor – Air-conditioning system	1 piece
PAF00072900	M8 x 20 hexagon socket head bolt – Front underbody cover	3 pieces
Required materials (usually already available in the Porsche Center):		
WPS10000001 ¹⁾	Refrigerant oil SP-A2 (250 ml container)	1 piece
WPS10000002 ²⁾	Refrigerant R134a	1 piece
or		
WPS10000003 ³⁾	Refrigerant R1234yf	1 piece
<p>¹⁾ For warranty processing, enter the corresponding part number with the designation 'Refrigerant SP-A2' as an external component in the warranty claim; maximum cost: \$6.51</p> <p>²⁾ For warranty processing, enter the corresponding part number with the designation 'Refrigerant R134a' as an external component in the warranty claim; maximum cost: \$5.42</p> <p>³⁾ For warranty processing, enter the corresponding part number with the designation 'Refrigerant R1234yf' as an external component in the warranty claim; maximum cost: \$16.26</p>		
⇒ Damage number WPS1 066 000 2		

Scope 7:

Checking pressure sensors and replacing pressure sensor PT2**Labor time:**

Checking pressure sensors and replacing pressure sensor PT2

Labor time: **332 TU**

Includes:

- Removing and installing front underbody cover
- Removing and installing front right wheel housing liner
- Removing and installing moulded hose at the bottom
- Loosening and fastening coolant line
- Loosening and fastening longitudinal member with sliding piece
- Draining and filling refrigerant
- Connecting and disconnecting battery charger
- Connecting and disconnecting PIWIS Tester
- Teaching pressure sensor using PIWIS Tester

Required parts:

Part No.	Designation – Location	Quantity
V04015959	Pressure sensor – Air-conditioning system	1 piece
PAF00072900	M8 x 20 hexagon socket head bolt – Front underbody cover	3 pieces

Required materials (usually already available in the Porsche Center):

WPS10000001 ¹⁾	Refrigerant oil SP-A2 (250 ml container)	1 piece
WPS10000002 ²⁾	Refrigerant R134a	1 piece
or		
WPS10000003 ³⁾	Refrigerant R1234yf	1 piece

¹⁾ For warranty processing, enter the corresponding part number with the designation 'Refrigerant SP-A2' **as an external component** in the warranty claim; maximum cost: \$6.51

²⁾ For warranty processing, enter the corresponding part number with the designation 'Refrigerant R134a' **as an external component** in the warranty claim; maximum cost: \$5.42

³⁾ For warranty processing, enter the corresponding part number with the designation 'Refrigerant R1234yf' **as an external component** in the warranty claim; maximum cost: \$16.26

⇒ **Damage number WPS1 066 000 2**

Scope 8: **Checking pressure sensors and replacing pressure sensor PT1 and pressure sensor PT2**

Labor time:

Checking pressure sensors and replacing pressure sensor PT1 and pressure sensor PT2 Labor time: **350 TU**

- Includes:
- Removing and installing front underbody cover
 - Removing and installing front right wheel housing liner
 - Removing and installing moulded hose at the bottom
 - Loosening and fastening coolant line
 - Loosening and fastening longitudinal member with sliding piece
 - Draining and filling refrigerant
 - Connecting and disconnecting battery charger
 - Connecting and disconnecting PIWIS Tester
 - Teaching pressure sensors using PIWIS Tester

Required parts:

Part No.	Designation – Location	Quantity
V04015959	Pressure sensor – Air-conditioning system	2 pieces
PAF00072900	M8 x 20 hexagon socket head bolt – Front underbody cover	3 pieces

Required materials (usually already available in the Porsche Center):

WPS10000001 ¹⁾	Refrigerant oil SP-A2 (250 ml container)	1 piece
WPS10000002 ²⁾	Refrigerant R134a	1 piece
or		
WPS10000003 ³⁾	Refrigerant R1234yf	1 piece

¹⁾ For warranty processing, enter the corresponding part number with the designation 'Refrigerant SP-A2' **as an external component** in the warranty claim; maximum cost: \$6.51

²⁾ For warranty processing, enter the corresponding part number with the designation 'Refrigerant R134a' **as an external component** in the warranty claim; maximum cost: \$5.42

³⁾ For warranty processing, enter the corresponding part number with the designation 'Refrigerant R1234yf' **as an external component** in the warranty claim; maximum cost: \$16.26

⇒ **Damage number WPS1 066 000 2**

Important Notice: Technical Bulletins issued by Porsche Cars North America, Inc. are intended only for use by professional automotive technicians who have attended Porsche service training courses. They are written to inform those technicians of conditions that may occur on some Porsche vehicles, or to provide information that could assist in the proper servicing of a vehicle. Porsche special tools may be necessary in order to perform certain operations identified in these bulletins. Use of tools and procedures other than those Porsche recommends in these bulletins may be detrimental to the safe operation of your vehicle, and may endanger the people working on it. Properly trained Porsche technicians have the equipment, tools, safety instructions, and know-how to do the job properly and safely. Part numbers listed in these bulletins are for reference only. The work procedures updated electronically in the Porsche PIWIS diagnostic and testing device take precedence and, in the event of a discrepancy, the work procedures in the PIWIS Tester are the ones that must be followed.

© 2024 Porsche Cars North America, Inc.