



Subject: CX-50 FRONT SEAT CUSHION AND FRONT SEAT BACK REMOVAL/INSTALLATION	Service Alert No.: SA-049/24
	Last Issued : 08/01/2024

BULLETIN NOTES

APPLICABLE MODEL(S)/VINS

2023-2025 CX-50

DESCRIPTION

The removal and installation procedures for front seat components are missing from MGSS. Please follow these two procedures in this SA until the WSM is updated.

REPAIR PROCEDURE

AIRBAG WARNINGS AND CAUTIONS: Handling a seat equipped with a side air bag improperly can accidentally operate (deploy) the air bag, which may seriously injure you. Read the service warnings and cautions in MGSS before handling a front seat that is equipped with a side airbag.

- AIR BAG SYSTEM SERVICE WARNINGS [TWO-STEP DEPLOYMENT CONTROL SYSTEM - US/CANADA SPEC.]
- AIR BAG SYSTEM SERVICE CAUTIONS [TWO-STEP DEPLOYMENT CONTROL SYSTEM - US/CANADA SPEC.]
- AIR BAG SYSTEM SERVICE WARNINGS [STANDARD DEPLOYMENT CONTROL SYSTEM - MEXICO SPEC.]
- AIR BAG SYSTEM SERVICE CAUTIONS [STANDARD DEPLOYMENT CONTROL SYSTEM - MEXICO SPEC.]

MANUAL SEAT WARNINGS AND CAUTIONS:

WARNING: If the sliding mechanisms on both sides are not locked after assembling the front seat, it may move unexpectedly while the vehicle is driven, which could result in serious injury. After assembling the front seat, try moving it back and forth to verify that the sliding mechanism on both sides is locked.

CAUTION:

CONSUMER NOTICE: The information and instructions in this bulletin are intended for use by skilled technicians. Mazda technicians utilize the proper tools/ equipment and take training to correctly and safely maintain Mazda vehicles. These instructions should not be performed by "do-it-yourselfers." Customers should not assume this bulletin applies to their vehicle or that their vehicle will develop the described concern. To determine if the information applies, customers should contact their nearest authorized Mazda dealership. Mazda North American Operations reserves the right to alter the specifications and contents of this bulletin without obligation or advance notice. All rights reserved. No part of this bulletin may be reproduced in any form or by any means, electronic or mechanical--including photocopying and recording and the use of any kind of information storage and retrieval system ---without permission in writing.

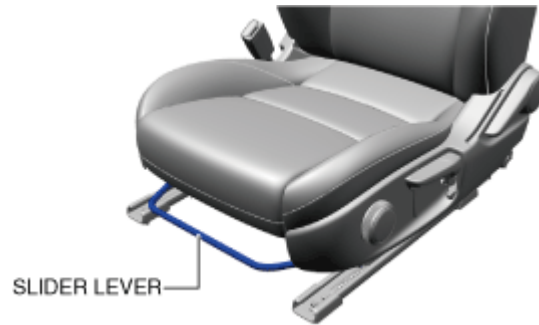

- After removing the front seat, do not operate the slider lever.
- After the front seat has been removed, if the slider lever is operated and the front seat is reinstalled with the left/right slide positions deviated, the adjuster unit could be damaged.
- Verify that there are no malfunctions in the forward/back slide of the seat and in the adjuster unit after installing a front seat.

FRONT SEAT CUSHION TRIM REMOVAL/INSTALLATION

1. Prepare a clean cloth so as not to damage or soil the seat when performing the procedure with the front seat removed from the vehicle.
2. Prepare C-rings and bands for use during reassembly. 4-6 of each may be required. (See the Parts Information for details.)
3. Remove the front seat belt lower anchor. (See FRONT SEAT BELT REMOVAL/INSTALLATION.)
4. Remove the front seat installation bolts. (See FRONT SEAT REMOVAL/INSTALLATION.)
5. Switch the ignition off.
6. Disconnect the negative battery terminal and wait for 1 minute or more. (See NEGATIVE BATTERY TERMINAL DISCONNECTION/CONNECTION.)
7. Remove the front seat. (See FRONT SEAT REMOVAL/INSTALLATION.)
8. Remove both front seat side covers. (See FRONT SEAT SIDE COVER REMOVAL/INSTALLATION.)
9. Move the hooks in the order of arrows (1) and (2) shown in the figure to detach the hooks from the springs.

CONSUMER NOTICE: The information and instructions in this bulletin are intended for use by skilled technicians. Mazda technicians utilize the proper tools/ equipment and take training to correctly and safely maintain Mazda vehicles. These instructions should not be performed by "do-it-yourselfers." Customers should not assume this bulletin applies to their vehicle or that their vehicle will develop the described concern. To determine if the information applies, customers should contact their nearest authorized Mazda dealership. Mazda North American Operations reserves the right to alter the specifications and contents of this bulletin without obligation or advance notice. All rights reserved. No part of this bulletin may be reproduced in any form or by any means, electronic or mechanical---including photocopying and recording and the use of any kind of information storage and retrieval system ---without permission in writing.

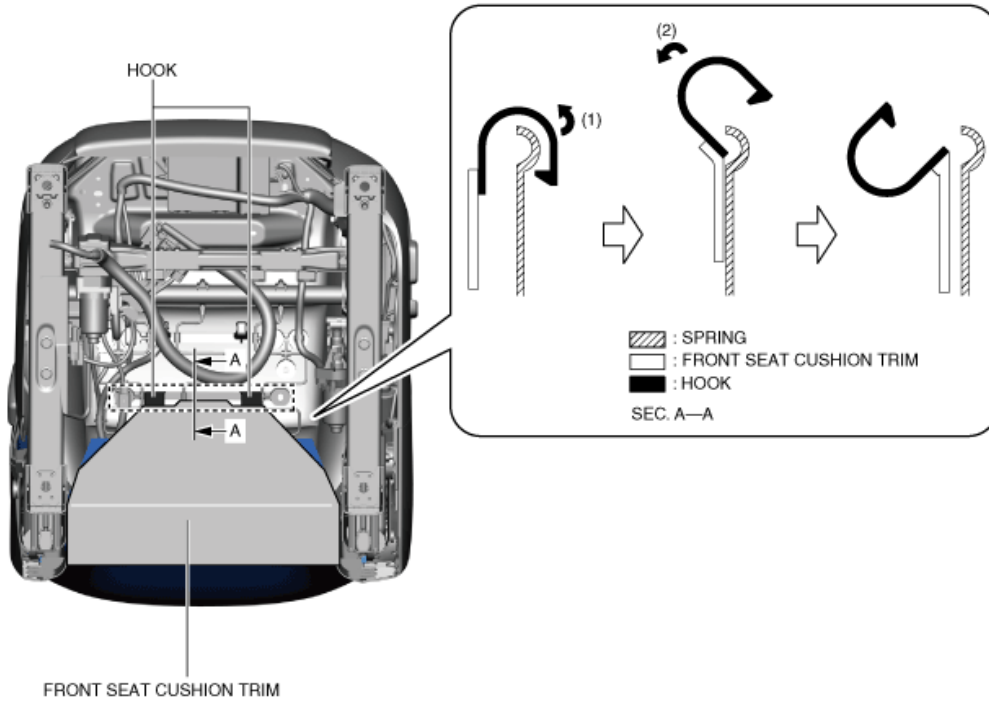

10. Disconnect the connectors shown below.

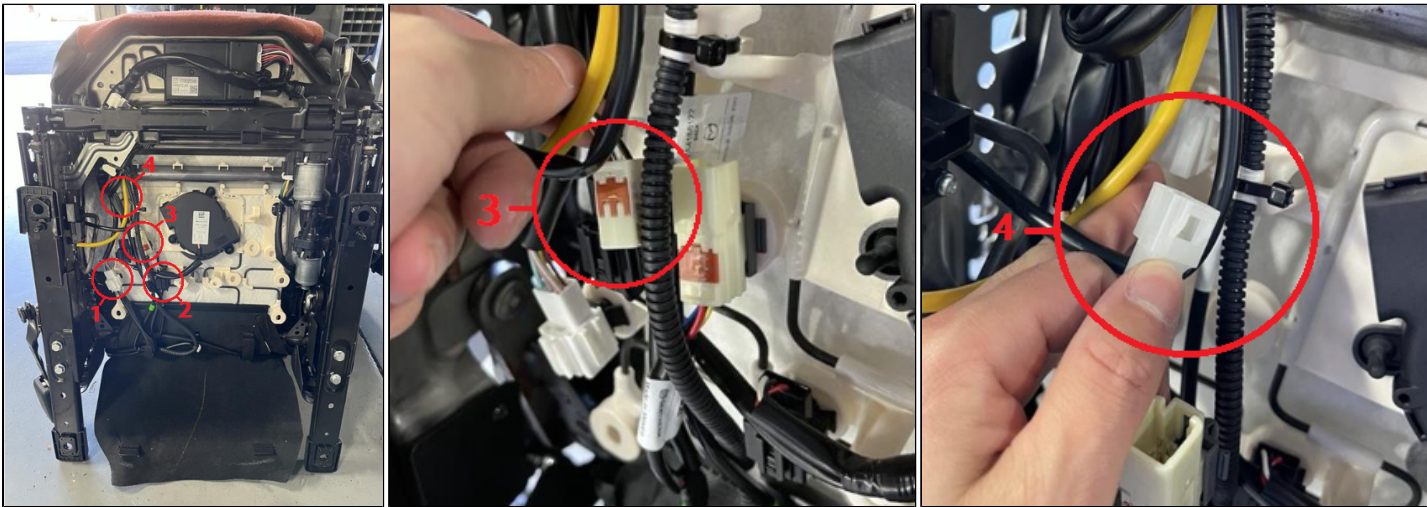

11. Remove the wiring harness clips.

CONSUMER NOTICE: The information and instructions in this bulletin are intended for use by skilled technicians. Mazda technicians utilize the proper tools/ equipment and take training to correctly and safely maintain Mazda vehicles. These instructions should not be performed by "do-it-yourselfers." Customers should not assume this bulletin applies to their vehicle or that their vehicle will develop the described concern. To determine if the information applies, customers should contact their nearest authorized Mazda dealership. Mazda North American Operations reserves the right to alter the specifications and contents of this bulletin without obligation or advance notice. All rights reserved. No part of this bulletin may be reproduced in any form or by any means, electronic or mechanical---including photocopying and recording and the use of any kind of information storage and retrieval system ---without permission in writing.

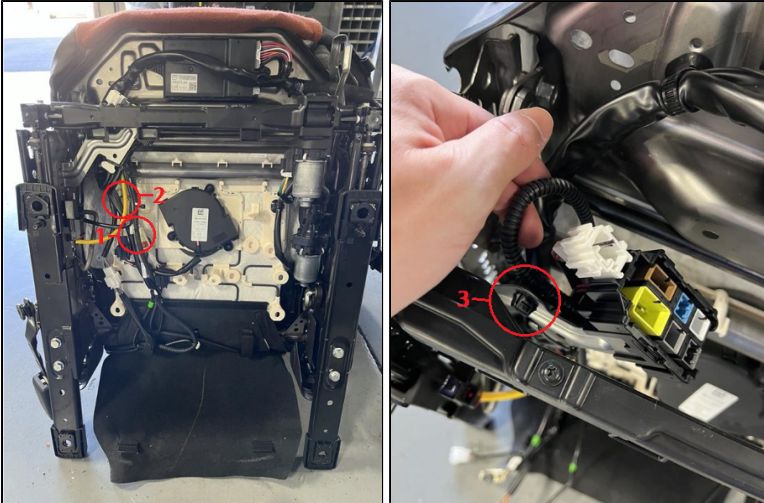

12. Cut the bands.

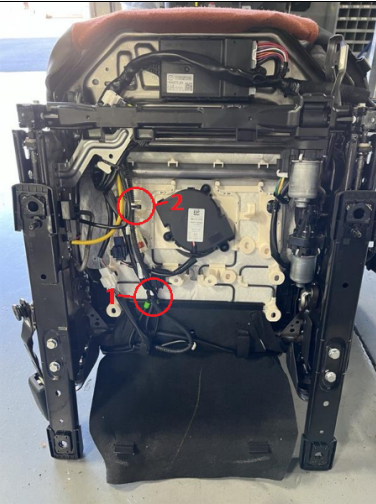

13. Move the hooks in the order of arrows (1) and (2) shown in the figure to detach the hooks from the front seat cushion frame. (See Front Seat Cushion Installation Note.)

CONSUMER NOTICE: The information and instructions in this bulletin are intended for use by skilled technicians. Mazda technicians utilize the proper tools/ equipment and take training to correctly and safely maintain Mazda vehicles. These instructions should not be performed by "do-it-yourselfers." Customers should not assume this bulletin applies to their vehicle or that their vehicle will develop the described concern. To determine if the information applies, customers should contact their nearest authorized Mazda dealership. Mazda North American Operations reserves the right to alter the specifications and contents of this bulletin without obligation or advance notice. All rights reserved. No part of this bulletin may be reproduced in any form or by any means, electronic or mechanical---including photocopying and recording and the use of any kind of information storage and retrieval system ---without permission in writing.

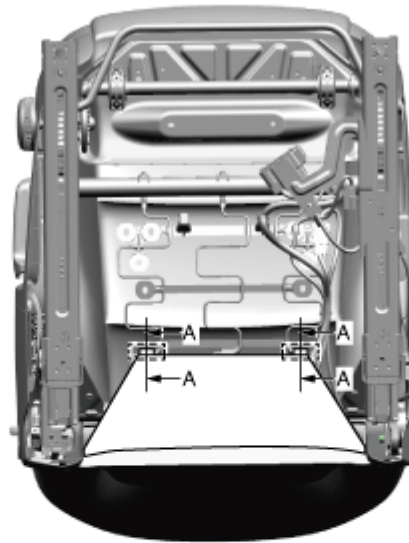

□ : HOOK

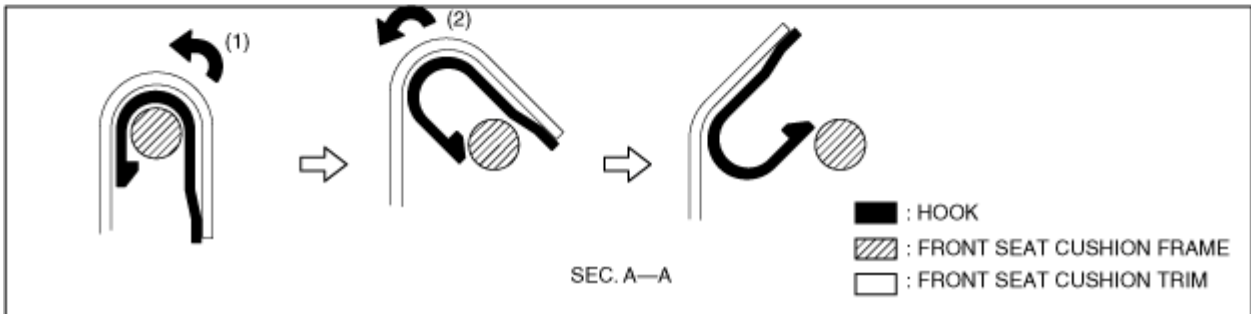

am3zzw00036719

14. Disconnect hooks between the seat cushion and the seat frame as shown below.

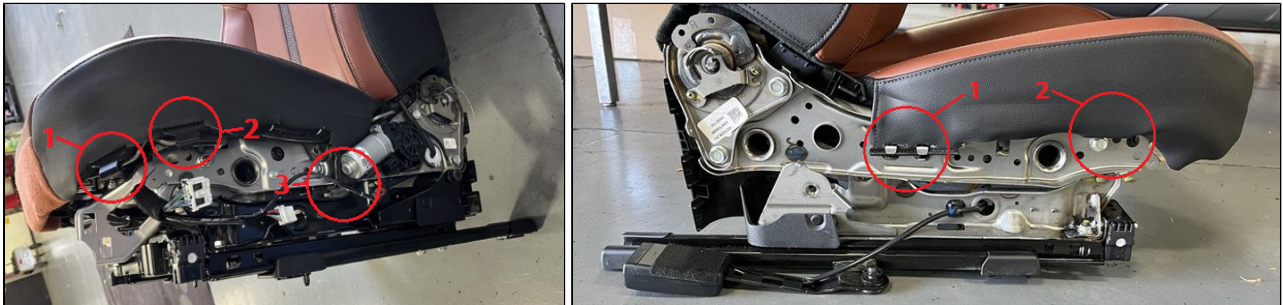

15. Move the hooks in the order of arrows (1) and (2) shown in the figure to detach the hooks from the front seat cushion frame.

CONSUMER NOTICE: The information and instructions in this bulletin are intended for use by skilled technicians. Mazda technicians utilize the proper tools/ equipment and take training to correctly and safely maintain Mazda vehicles. These instructions should not be performed by "do-it-yourselfers." Customers should not assume this bulletin applies to their vehicle or that their vehicle will develop the described concern. To determine if the information applies, customers should contact their nearest authorized Mazda dealership. Mazda North American Operations reserves the right to alter the specifications and contents of this bulletin without obligation or advance notice. All rights reserved. No part of this bulletin may be reproduced in any form or by any means, electronic or mechanical--including photocopying and recording and the use of any kind of information storage and retrieval system ---without permission in writing.

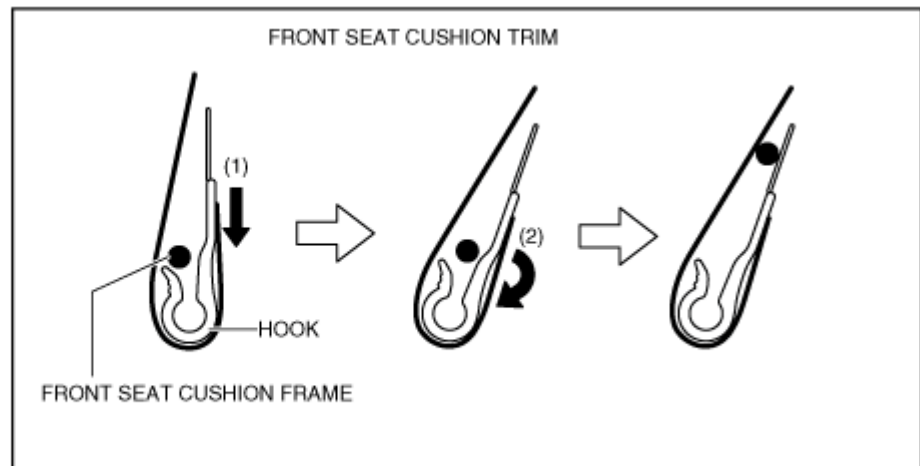
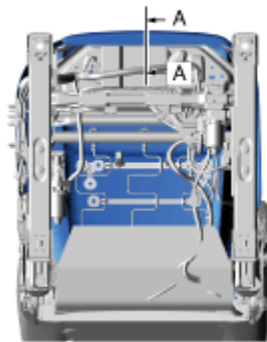

SEC. A—A

ac30zw00005523

16. Install in the reverse order of removal.

17. If the passenger seat was repaired, follow the appropriate weight sensor procedure:

- Passenger's seat is *removed*:
Perform the seat weight sensor inspection using the M-MDS after installing the passenger's seat. (See SEAT WEIGHT SENSOR INSPECTION [TWO-STEP DEPLOYMENT CONTROL SYSTEM - US/ CANADA SPEC.])
- Passenger's seat components are *replaced with a new one*:
Perform the seat weight sensor calibration using the M-MDS. (See SEAT WEIGHT SENSOR CALIBRATION [TWO-STEP DEPLOYMENT CONTROL SYSTEM - US/ CANADA SPEC.])

18. Check for wrinkles. If there are wrinkles, see the section titled "SEAT WRINKLES".

FRONT SEATBACK TRIM REMOVAL/INSTALLATION

1. Prepare a clean cloth so as not to damage or soil the seat when performing the procedure with the front seat removed from the vehicle.
2. Prepare C-rings and bands for use during reassembly. 4-6 of each may be required. (See the Parts Information for details.)
3. Remove the head restraint.
4. Remove the front seat installation bolts. (See FRONT SEAT REMOVAL/INSTALLATION.)
5. Remove the front seat belt lower anchor. (See FRONT SEAT BELT REMOVAL/INSTALLATION.)
6. Perform the following procedure.
 - a. Switch the ignition off.
 - b. Disconnect the negative battery terminal and wait for 1 minute or more. (See NEGATIVE BATTERY TERMINAL DISCONNECTION/CONNECTION.)
7. Remove the front seat. (See FRONT SEAT REMOVAL/INSTALLATION.)
8. Move the hook in the order of arrows (1) and (2) shown in the figure and set the front seat cushion trim away from the front seat cushion frame.

CONSUMER NOTICE: The information and instructions in this bulletin are intended for use by skilled technicians. Mazda technicians utilize the proper tools/ equipment and take training to correctly and safely maintain Mazda vehicles. These instructions should not be performed by "do-it-yourselfers." Customers should not assume this bulletin applies to their vehicle or that their vehicle will develop the described concern. To determine if the information applies, customers should contact their nearest authorized Mazda dealership. Mazda North American Operations reserves the right to alter the specifications and contents of this bulletin without obligation or advance notice. All rights reserved. No part of this bulletin may be reproduced in any form or by any means, electronic or mechanical--including photocopying and recording and the use of any kind of information storage and retrieval system ---without permission in writing.

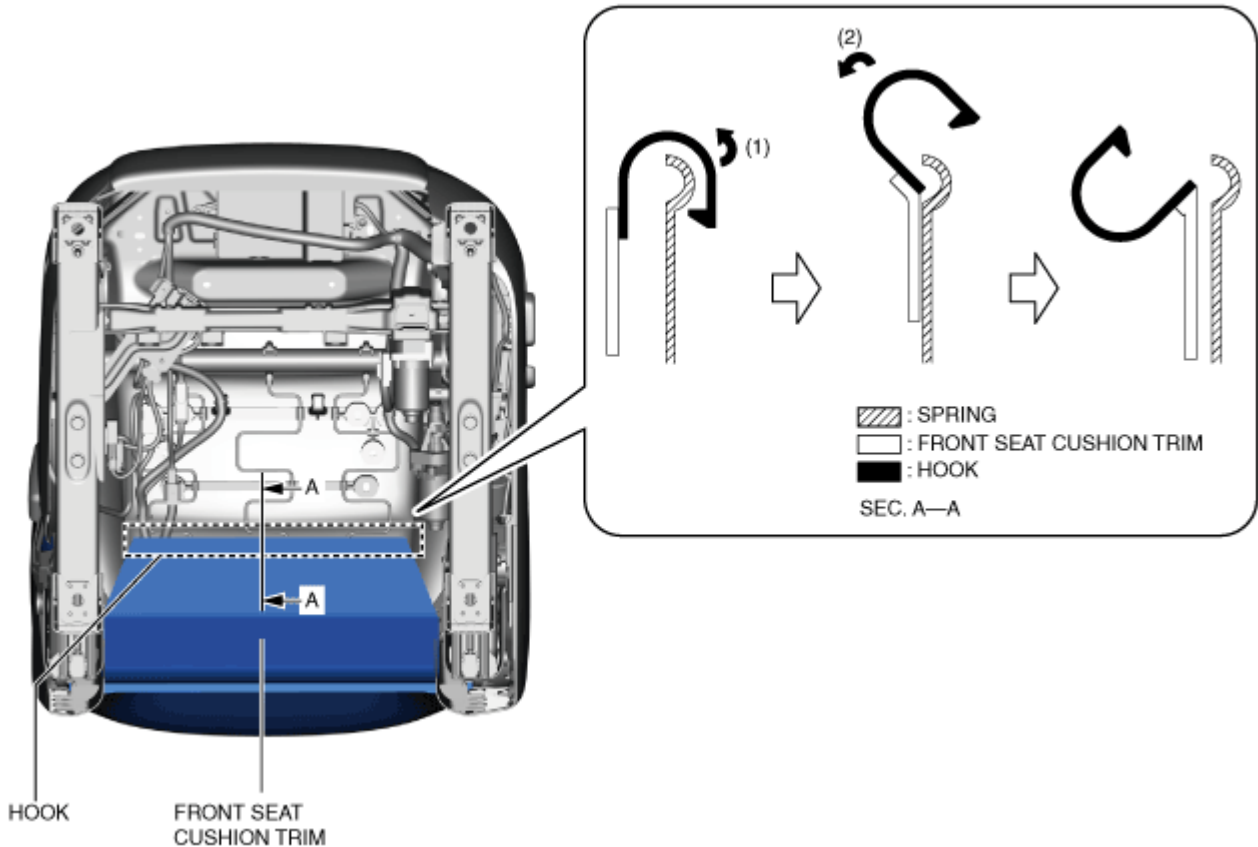

ac30zw00002625

9. Remove the wiring harness clip. (See FRONT SEAT REMOVAL/INSTALLATION.)
10. Disconnect the connectors. (See FRONT SEAT REMOVAL/INSTALLATION.)
11. Remove the bands. (See FRONT SEAT REMOVAL/INSTALLATION.)
12. Move hook A in the order of arrows (1) and (2) shown in the figure and detach it from hook B.

CONSUMER NOTICE: The information and instructions in this bulletin are intended for use by skilled technicians. Mazda technicians utilize the proper tools/ equipment and take training to correctly and safely maintain Mazda vehicles. These instructions should not be performed by "do-it-yourselfers." Customers should not assume this bulletin applies to their vehicle or that their vehicle will develop the described concern. To determine if the information applies, customers should contact their nearest authorized Mazda dealership. Mazda North American Operations reserves the right to alter the specifications and contents of this bulletin without obligation or advance notice. All rights reserved. No part of this bulletin may be reproduced in any form or by any means, electronic or mechanical--including photocopying and recording and the use of any kind of information storage and retrieval system ---without permission in writing.

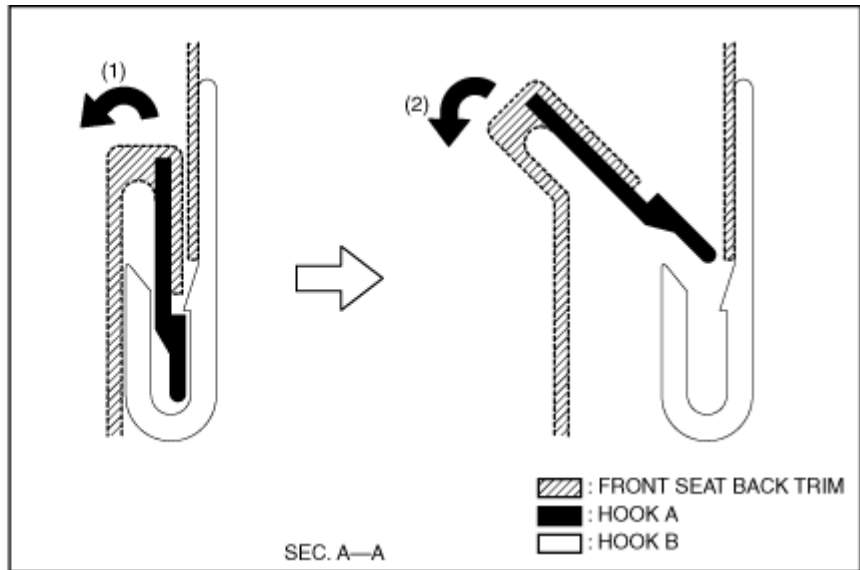
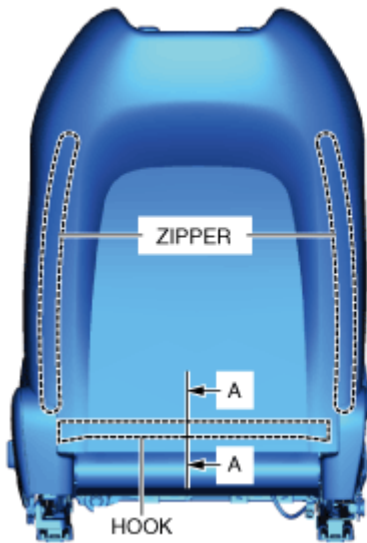

am3zzw00025789

13. Unzip the zippers.

CAUTION:

- If a C-ring is damaged while removing or installing the front seat cushion trim and front seat cushion frame, it may not be possible to install the front seat cushion trim and front seat cushion frame normally. When removing or installing the front seat cushion trim and front seat cushion frame, be careful not to damage the C-rings.
- If a C-ring is damaged, replace it with a new one.

14. Remove the C-rings.

15. While pressing the tabs in the direction of arrows (1) shown in the figure, pull the pole guides in the direction of arrow (2) and remove the pole guides from the front seat back frame.

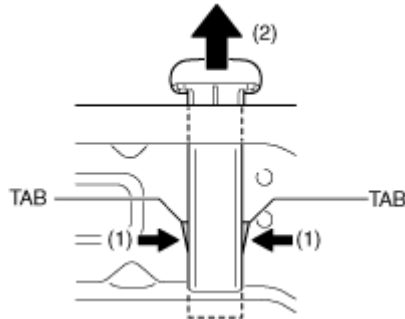

ac30zw00002735

16. Remove the nut.

CONSUMER NOTICE: The information and instructions in this bulletin are intended for use by skilled technicians. Mazda technicians utilize the proper tools/ equipment and take training to correctly and safely maintain Mazda vehicles. These instructions should not be performed by "do-it-yourselfers." Customers should not assume this bulletin applies to their vehicle or that their vehicle will develop the described concern. To determine if the information applies, customers should contact their nearest authorized Mazda dealership. Mazda North American Operations reserves the right to alter the specifications and contents of this bulletin without obligation or advance notice. All rights reserved. No part of this bulletin may be reproduced in any form or by any means, electronic or mechanical--including photocopying and recording and the use of any kind of information storage and retrieval system ---without permission in writing.

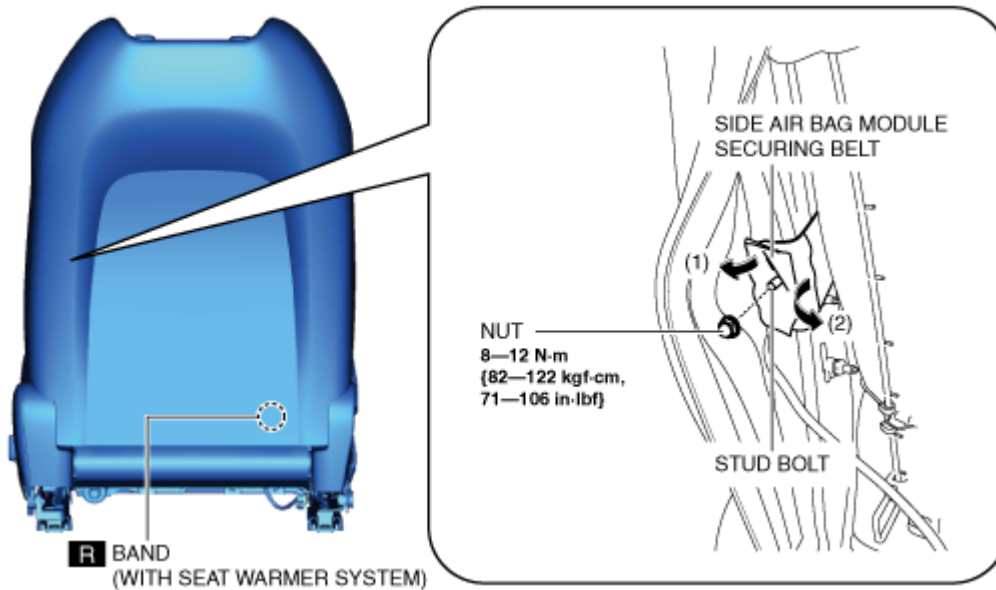

ac30zw00002734

17. Pull the side airbag module securing belt in the direction of arrows (1) and (2) and remove it from the front seat back frame stud bolt.
18. Remove the band.
19. Pull out the front seat back pad, the front seat back trim, and the front seat back warmer wiring harness (with seat warmer system) toward the front of the front seat.

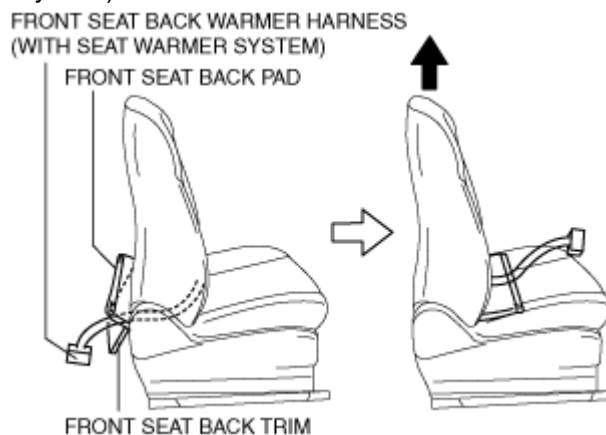

am3uuw00012969

20. Lift the front seat back trim and remove it from the front seat back frame.
21. Install in the reverse order of removal.
22. Check for wrinkles. If there are wrinkles, see the section titled "SEAT WRINKLES".

LEATHER SEAT WRINKLES

If the new **leather** seat trim has wrinkles, see TSB 09-036/24 - WRINKLES ON LEATHER SEAT SURFACE OF NEW (UNSOLD) VEHICLE for the procedure to remove the wrinkles.

CONSUMER NOTICE: The information and instructions in this bulletin are intended for use by skilled technicians. Mazda technicians utilize the proper tools/ equipment and take training to correctly and safely maintain Mazda vehicles. These instructions should not be performed by "do-it-yourselfers." Customers should not assume this bulletin applies to their vehicle or that their vehicle will develop the described concern. To determine if the information applies, customers should contact their nearest authorized Mazda dealership. Mazda North American Operations reserves the right to alter the specifications and contents of this bulletin without obligation or advance notice. All rights reserved. No part of this bulletin may be reproduced in any form or by any means, electronic or mechanical--including photocopying and recording and the use of any kind of information storage and retrieval system ---without permission in writing.

NOTE: DO NOT use the steam iron on areas made of leatherette (red areas in the image below) or the trim will be damaged and will not be covered under warranty.

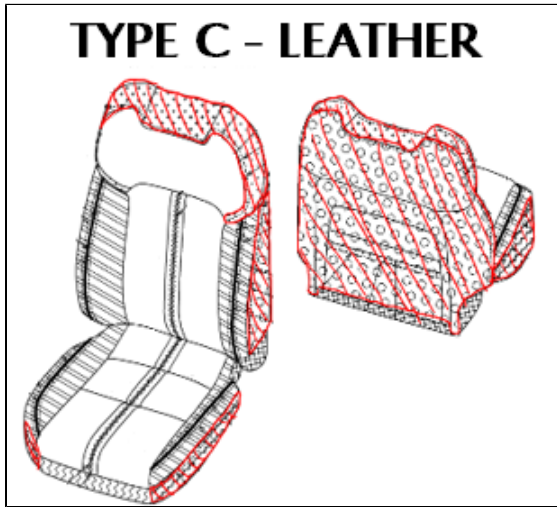

PARTS INFORMATION

Parts Number	Description	Qty.	Notes
KD7J-88-244	BAND	4-8	<ul style="list-style-type: none"> Quantity one per part number. Total quantity varies by manual/power seat and if you are removing the seat bottom, seatback, or both. Can be sourced locally. Also known in the US as cable tie, zip tie, wire tie, tie wrap, tie strap, hose tie, and other variations.
H430-67-C91	CLIP	4-6	<ul style="list-style-type: none"> Quantity one per part number. Total quantity varies by manual/power seat and if you are removing the seat bottom, seatback, or both. Can be sourced locally. Referred to as a "BAND" in the repair procedure. Also known in the US as cable tie, zip tie, wire tie, tie wrap, tie strap, hose tie, and other variations.
0824-88-049	CLIP	4-6	<ul style="list-style-type: none"> Quantity one is package of 90. Can be sourced locally. Referred to as a "C-RING" in the repair procedure.

CONSUMER NOTICE: The information and instructions in this bulletin are intended for use by skilled technicians. Mazda technicians utilize the proper tools/ equipment and take training to correctly and safely maintain Mazda vehicles. These instructions should not be performed by "do-it-yourselfers." Customers should not assume this bulletin applies to their vehicle or that their vehicle will develop the described concern. To determine if the information applies, customers should contact their nearest authorized Mazda dealership. Mazda North American Operations reserves the right to alter the specifications and contents of this bulletin without obligation or advance notice. All rights reserved. No part of this bulletin may be reproduced in any form or by any means, electronic or mechanical--including photocopying and recording and the use of any kind of information storage and retrieval system ---without permission in writing.

Parts Number	Description	Qty.	Notes
			<ul style="list-style-type: none">• Also known in the US as a "hog ring". Can be sourced locally.

CONSUMER NOTICE: The information and instructions in this bulletin are intended for use by skilled technicians. Mazda technicians utilize the proper tools/ equipment and take training to correctly and safely maintain Mazda vehicles. These instructions should not be performed by "do-it-yourselfers." Customers should not assume this bulletin applies to their vehicle or that their vehicle will develop the described concern. To determine if the information applies, customers should contact their nearest authorized Mazda dealership. Mazda North American Operations reserves the right to alter the specifications and contents of this bulletin without obligation or advance notice. All rights reserved. No part of this bulletin may be reproduced in any form or by any means, electronic or mechanical---including photocopying and recording and the use of any kind of information storage and retrieval system ---without permission in writing.