



Upper Radiator Hose Replacement (2.25 Crank Angle)

Service Category Service Department

Section Function Group 261

Technician Skill Level C

Market North America

Applicability

Mack

Model Years	Models
2023-2024	AN

Introduction

Mack trucks has determined that certain 2023 and 2024 model year AN vehicles could experience an issue with the upper radiator hose collapsing or deforming causing it to leak or interfere with the engine lifting bracket. To correct this issue, follow the instructions below to replace the upper radiator hose with a new one.

Production Change Information

This bulletin applies to vehicles built within the specified production changes below.

Brand	Engine	Emission Level	Starting Build Date	Ending Build Date
Mack	MP8	EM-EC01, EM-EU5, EM-USA21	31-May-2022	19-May-2023

Warranty Information

This repair is covered by an authorized Service Program. Reimbursement is obtained through the normal claim handling process.		
Claim Type (used only when uploading from the Dealer Bus. Sys.)		B
Main Labor Code	Description	Hours
2615-03-02-01	Radiator Hose, Replacement (Upper)	0.6
Causal Part	23278115	
SCC Authorization Code	S3586	
Expiration Date	December 31, 2024	

Parts Information

Part Numbers	Part Names	Quantity
24519036	Upper Radiator Hose	1

Required Tools & Equipment

N/A

Repair Procedure

1. Park the vehicle on a level surface.
2. Apply the parking brake.
3. Place the gear lever in neutral.
4. Install the wheel chocks.

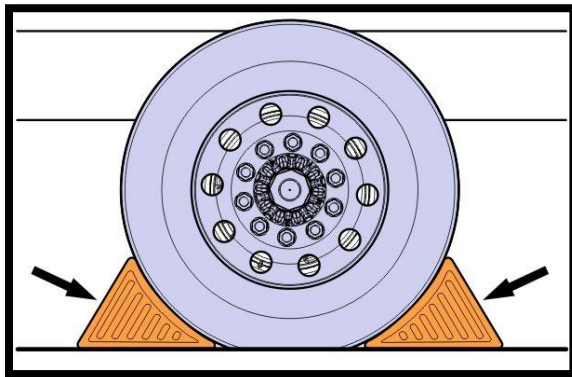

5. Unlatch and raise the hood.
6. Drain the coolant using either a coolant extractor or a drain hose and pan.

Required material	
Extractor	88870007
Drain Hose	9996049

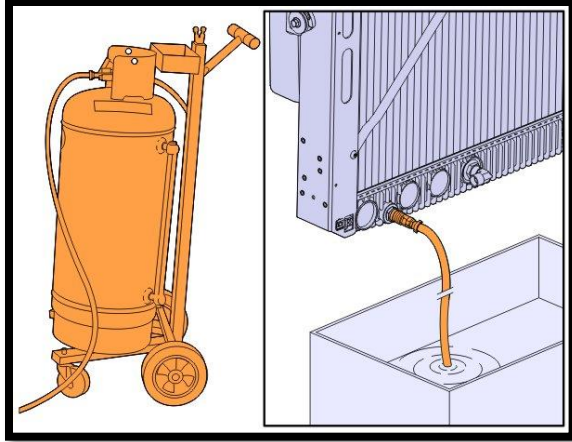

7. Loosen the hose clamp.

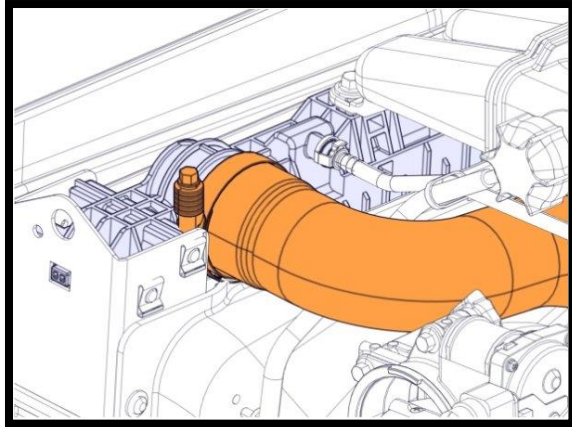

8. Remove the screws and clamp.

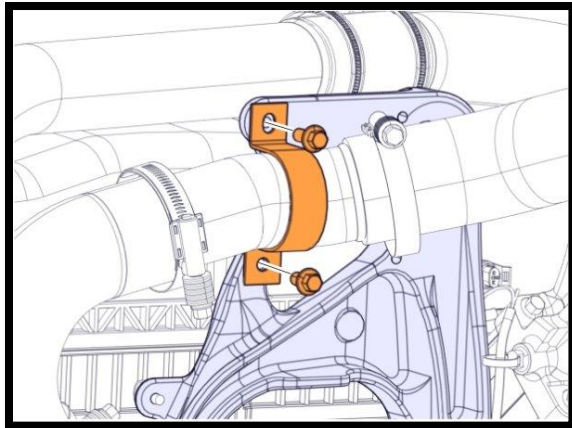

9. Remove the lower clamp.

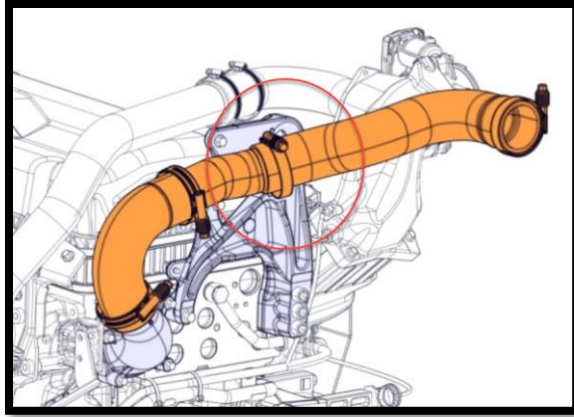

10. Remove the upper radiator hose and discard.
11. Install the new upper radiator hose **24519036**.
12. Install and align both clamps.
13. Tighten both hose clamps.

Tightening torque	
Radiator hose, clamp	5.5 ±0.8 Nm (4 ±1 lb _r -ft)

14. Install clamp and screws.

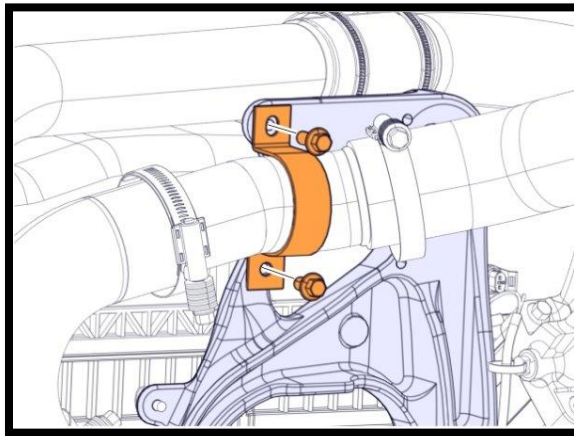

15. Tighten screws.

Tightening torque	
screws	24 ±4 Nm (18 ±3 lb _r -ft)

16. Fill the system with coolant.

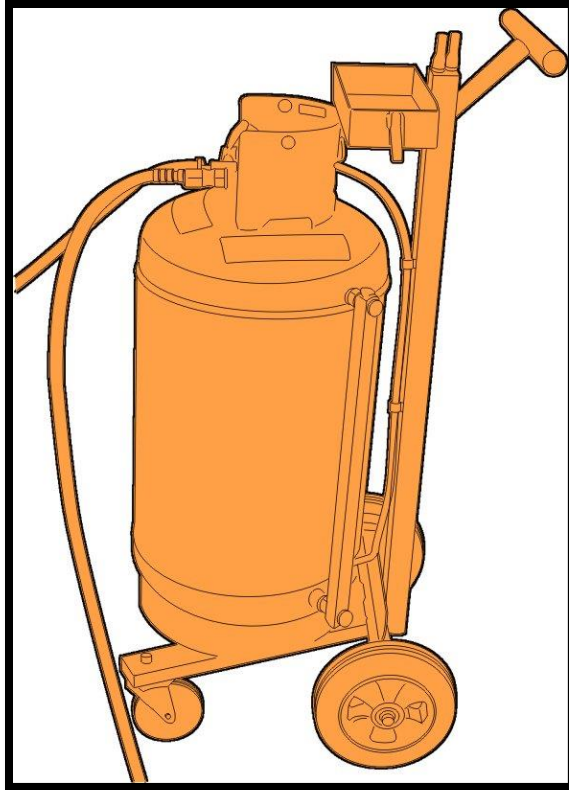

17. Connect the cable to the negative terminal.

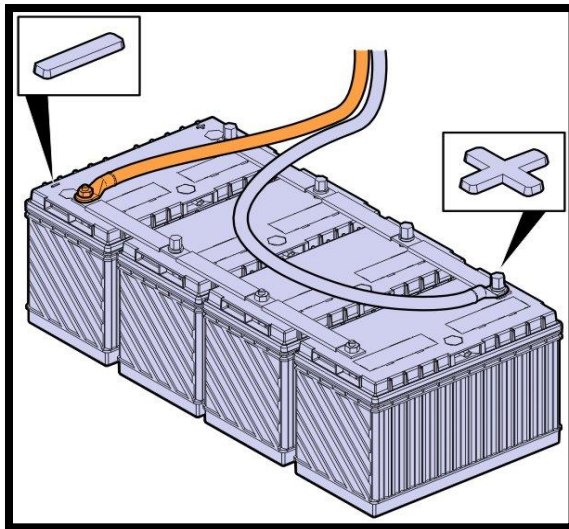

18. Start the engine and check for leaks.

19. Remove the wheel chocks.

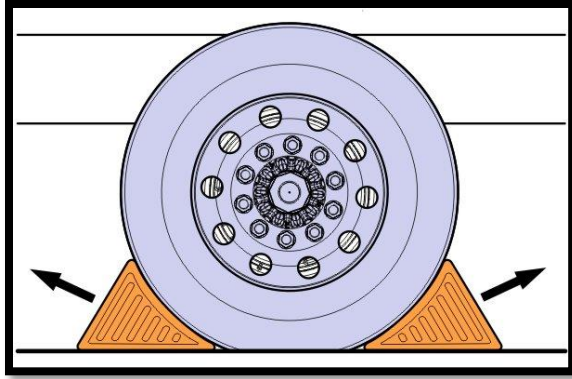

20. Return vehicle to service.