



Preliminary Information

PIP5926C Transmission Fluid Leak Between the Transmission and Transfer Case

Models

Brand:	Model:	Model Years:	VIN:		Engine:	Transmissions:
			from	to		
Chevrolet	Silverado 2500/3500	2020 - 2024	ALL	ALL	L5P L8T	MKM MGM MGU
GMC	Sierra 2500/3500	2020 - 2024	ALL	ALL	L5P L8T	MKM MGM MGU

Involved Region or Country	North America, Middle East, Israel and Australia/New Zealand.
Additional RPO	NQF NQH
Condition	Some customers or technicians may comment of a transmission fluid leak between the transmission and transfer case.
Cause	The Transmission Case Extension Seal (call out 1 second pic below) is leaking or the Transfer Case Input Shaft Seal (call out 1 third pic below).

Correction:

Replace the Transmission Case Extension Seal (call out 1 second pic below) and Transfer Case Input Shaft Seal (call out 1 third pic below).

Note: The cavity between the Transmission and Transfer Case is a wet cavity by design. The Transfer Case Input Shaft Seal is a double seal to prevent fluid transmission and transfer case fluid from intermixing with each. If either side of the seal leaks fluid will leak from the weep holes between the Transmission and Transfer Case.

Note: It is being reported that the t-case input seal may be installed backwards, as a two piece seal back to back, and the replacement seal may also come as two seals to be installed. Correct orientation if two seals are received is metal clad together, which may be rubber coated, garner springs need to facing opposite of each other, one spring facing the t-case input gear, and one spring facing towards the trans output shaft, additionally, each seal may have three tabs, one seal protruding tabs, and the other inverted tabs, those tabs are to be aligned for proper installation.

Adding dye to either the transfer case or transmission will help determine if the seal depth is incorrect.

If the seal is installed to deep the fluid leaking is transmission fluid.

If the seal is not installed deep enough the fluid leaking is transfer case fluid.

Either condition will cause fluid to leak out of the weep holes between the transmission and transfer case.

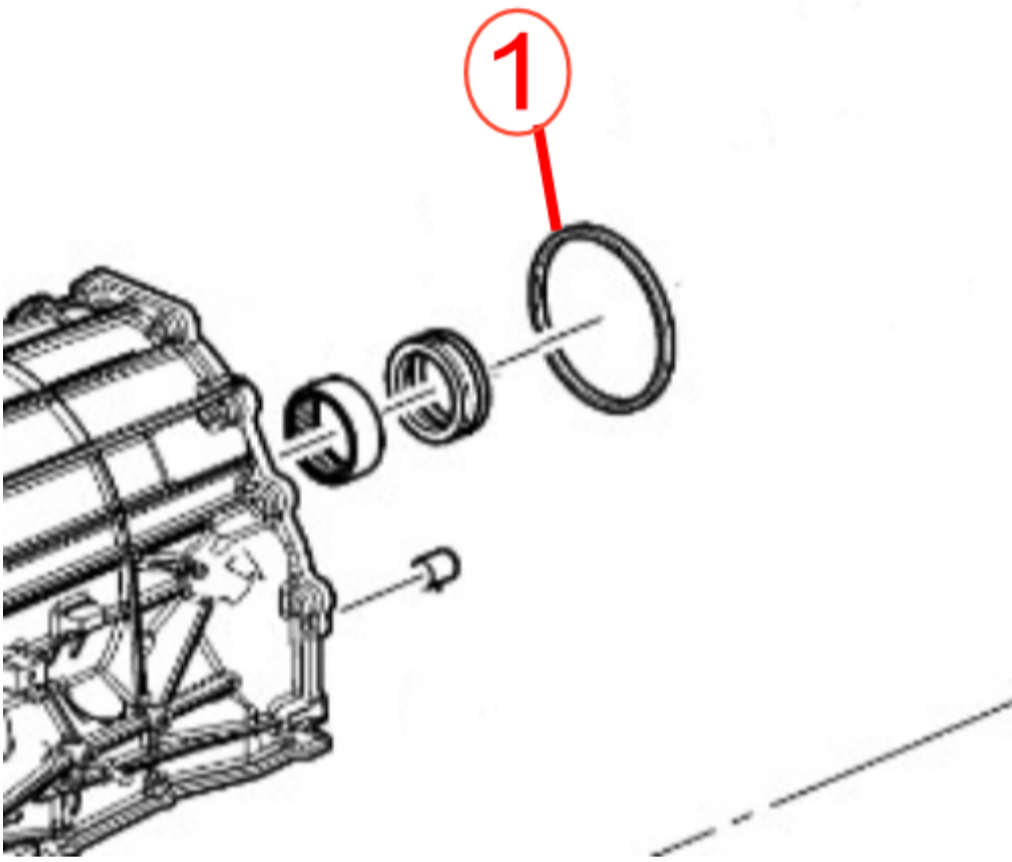

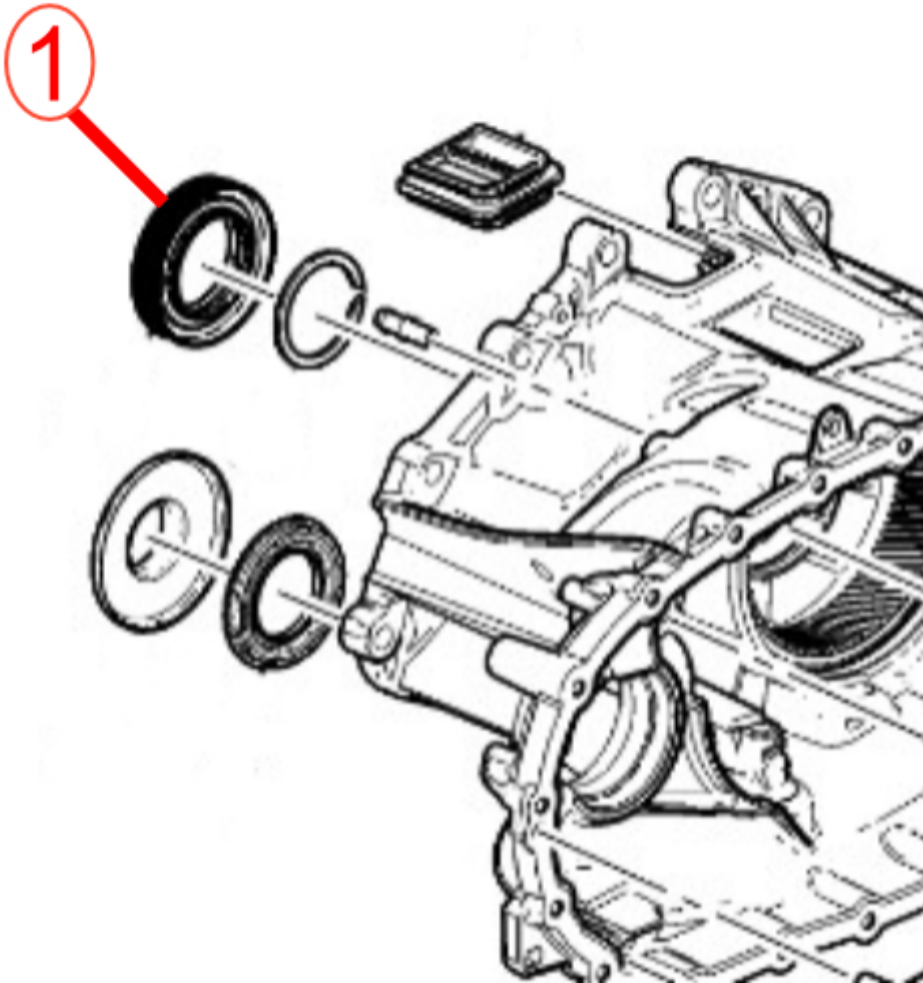

MKM MGM MGU NQF NQH

Note: Review the latest version of PIP5810 for proper Transfer Case Input Shaft Seal Installation Instructions. Improper Transfer Case Extension Seal installation will result in repeat leaks.

Note: Follow the published t-case alignment bolt torque and sequence pattern during the installation process, example reference in SI# 6283514, at the bottom of the page.

Note: For Model Year 2022 review the latest version of TSB 22-NA-137 for a possible Case Plug. Note the Case Plug issue should have presented itself at low mileage.

** This PI will be updated to a TSB as more information becomes available. **

Version History

Version	4
Modified	<p>06/07/2023 - Created.</p> <p>06/16/2023 - Updated to include note that the t-case input seal may be received as two separate seals, with information for proper orientation for installation.</p> <p>06/26/2023 - Updated to clarify reference documents.</p> <p>05/07/2024 - Removed PIP5857 and added TSB 22-NA-137.</p>



GENERAL MOTORS