



STAR ONLINE PUBLICATION



Case Number: S2423000030 Rev. A

Release Date: August 2024

Symptom/Vehicle Issue: Buzz Squeak Rattle (BSR) From Upper Left Dash Area.

Customer Complaint/Technician Observation: Customer may describe a noise that sounds like radio static or a light rattle. Noise could be intermittent and only on rough surface roads.

Discussion: This document discusses 2 possible causes. Please read through both before attempting repair.

1. Attempt to duplicate the noise with the radio off. If the condition is still there with no audio input, examine the heads-up display (HUD) fastener clips. The clips may be installed on vehicles without the HUD option. See Fig 1. Refer to Service Library 08 - Electrical / 8J - Instrument Cluster / DISPLAY, Heads Up / Removal and Installation. If the fasteners are ok and tight then continue to step 2.
2. Using a handheld plastic 0.50mm feeler gauge, see if it will fit between the rear edge (closest to driver) of the HUD Bezel and the HUD Screen. If the Plastic Feeler will not go in the space, then a repair is needed.

A. Using a Plastic Trim Stick remove the HUD Bezel

B. On the back side of the HUD Bezel at the Rear Edge add 3 pcs of flock tape (MOPAR 6823057AB 25mm x 25mm x 1mm thick) placed approximately 35mm from each other as shown in Fig 2. Tape application will be on the rearward side (facing occupants) of the bezel. After tape installation, install the bezel and verify condition is resolved.

This document does not authorize warranty repairs. This communication documents a record of past experiences. STAR Online does not provide any conclusions about what is wrong with the vehicle. Rather, it captures all previous cases known that appear to be similar or related to the vehicle symptom / condition. You are the expert, and you are responsible for deciding on the appropriate course of action.

Contact STAR Center, or your Technical Assistance Center Via TechConnect, eCONTACT or Service Library entry if no solution is found.



STAR ONLINE PUBLICATION

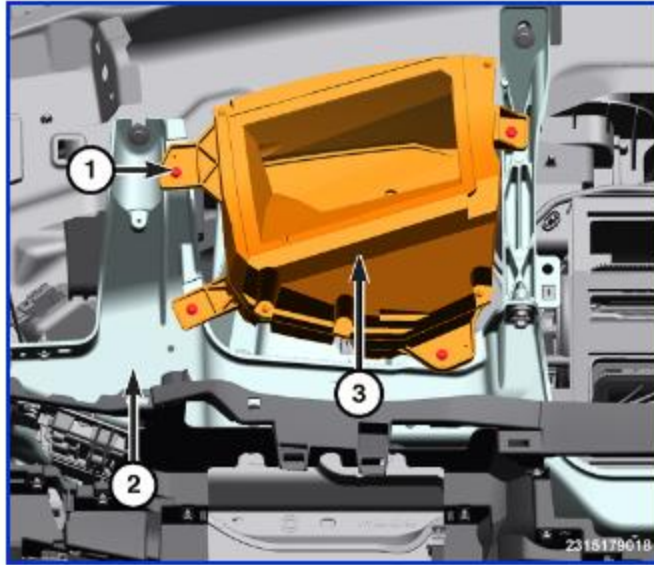

- 1 - Fasteners
- 2 - Instrument Panel Carrier
- 3 - Heads Up Display (HUD) Module

Fig 1

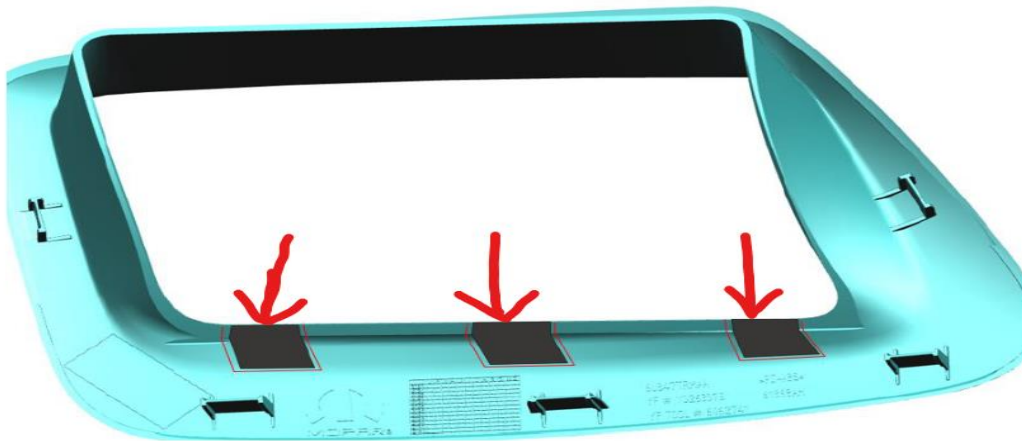

Fig 2.
68230057AB tape locations

This document does not authorize warranty repairs. This communication documents a record of past experiences. STAR Online does not provide any conclusions about what is wrong with the vehicle. Rather, it captures all previous cases known that appear to be similar or related to the vehicle symptom / condition. You are the expert, and you are responsible for deciding on the appropriate course of action.

Contact STAR Center, or your Technical Assistance Center Via TechConnect, eCONTACT or Service Library entry if no solution is found.