



Technical Service Bulletin

SUBJECT:		No: TSB-16-54-001REV	
FUSE HANDS FREE LINK SYSTEM: UNSTABLE BLUETOOTH® CONNECTION - REVISED		DATE: July 2024	
		MODEL: See below	
CIRCULATE TO:	<input type="checkbox"/> GENERAL MANAGER	<input checked="" type="checkbox"/> PARTS MANAGER	<input checked="" type="checkbox"/> TECHNICIAN
<input checked="" type="checkbox"/> SERVICE ADVISOR	<input checked="" type="checkbox"/> SERVICE MANAGER	<input checked="" type="checkbox"/> WARRANTY PROCESSOR	<input checked="" type="checkbox"/> SALES MANAGER

This bulletin supersedes TSB-16-54-001 dated January 2016 to update the procedures about how to obtain the USB flash drive software. Revisions are italicized and indicated by ◀

PURPOSE

Some customers may report that the connection between the FUSE Hands Free Link System (also called Hands Free Module / HFM) and iPhone is unstable, repeatedly connecting and disconnecting from the vehicle's Bluetooth when the iPhone's Wi-Fi is enabled. The condition does not occur when Wi-Fi is turned off.

During normal operation, the HFM sends signals searching for available devices to connect with via Bluetooth. Once it finds a device, the HFM establishes a connection.

If the device is an iPhone/iPod/iPad, and a Wi-Fi connection is in operation, the HFM sees the device as not available and ends the connection. After disconnecting, the HFM searches for available devices again, and reconnects.

This TSB instructs the dealer to update the HFM software to improve the Bluetooth connection with iPhone/iPod/iPad when the device is connected to Wi-Fi.

The new HFM software also improves the following conditions when using a USB cable connection:

- Music title is not displayed when playing music with iPhone/iPod/iPad via USB connection
- Music repeatedly stops playing after one song is completed when playing music with iPhone/iPod/iPad via Bluetooth
- If Fast-Forward is pressed while using the Repeat function, the music stops at the end of the song, and the Fast-Forward search is discontinued

NOTE:

- The new HFM software includes the latest database of music titles provided by Gracenote.
- With this update, music cannot be played with a USB connection if the Apple device iOS is version 4.0 or earlier.

AFFECTED VEHICLES

The following models equipped with FUSE Hands Free Link System and USB terminal

- 2012–2016 i-MiEV
- 2011–2015 Lancer
- 2011–2015 Lancer Ralliart
- 2011–2014 Lancer Sportback
- 2011 Lancer Sportback Ralliart
- 2011–2015 Lancer Evolution
- 2014–2015 Mirage (ES, Non-Navi)
- 2010–2016 Outlander
- 2011–2016 Outlander Sport/RVR

Copyright 2024, Mitsubishi Motors North America, Inc.

The information contained in this bulletin is subject to change. For the latest version of this document, go to the Mitsubishi Dealer Link, MEDIC, or the Mitsubishi Service Information website (www.mitsubishitechinfo.com).

ADDITIONAL INFORMATION

!! IMPORTANT !!

Updating the software will cause the following to be erased from the HFM. You **MUST** notify the customer of this before updating.

- Phonebook entry data
- Pairing data
- Voice training data

REQUIRED EQUIPMENT

When a vehicle diagnosis supports updating the Display Audio (SDA) software, please contact Techline. Techline will ship the thumb drive with the applicable software to you via FedEx.

The reprogramming software is intellectual property which belongs to the supplier. Please erase the program file from the USB memory once the reprogramming has been performed or securely store the software to use when customers ask about any of the conditions mentioned in the PURPOSE section.

CAUTION: Be sure to **ONLY** use the correct Software Version for the vehicle you are updating. Updating a vehicle with another model's software may affect model specific parameters, such as vehicle information not displaying correctly.

PROCEDURE

Check the Current Software Version

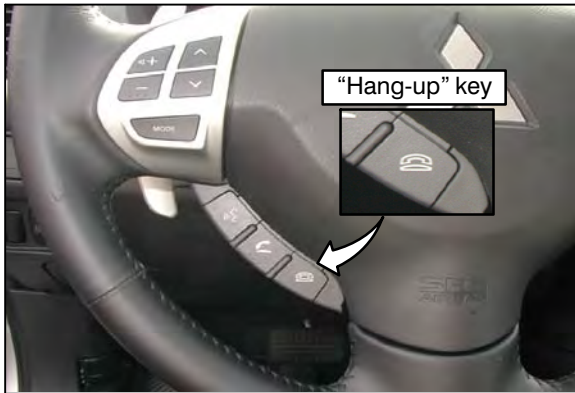

1. Wait at least 1 minute after starting the engine, then perform steps a – c within 10 seconds.
 - a. Press and hold the “hang-up” key (📞) on the steering wheel for 2 seconds or longer, then release (within 1 second).
 - b. Repeat step 1a.
 - c. Press and release 📞 for less than 1 second.
Voice guidance will announce the software version number.

For example: If the software version is 11.0.0, voice guidance announces “1,” “1,” “0,” “0.”

NOTE: If no response is heard, repeat steps a – c. It is not necessary to restart the engine.

If the software version is 9.0.0 or earlier, there will be no response.

For models with MMCS and Display Radio, it may be necessary to go to the Service Mode option to check the current version. Refer to the MMCS Navigation section later in this TSB for instructions.

2. Verify that the software version is 18.00.000 or earlier.
 - NG: Software version = 18.00.000 or earlier. Proceed with the procedure in this TSB.
 - OK: Software version = 19.00.000. Software is already updated.

A. Update the FUSE Hands Free Link System

!! IMPORTANT !!

This TSB provides three (3) separate procedures. One for MMCS Navigation, one for Display Audio, and one for single CD radios. Please make sure you use the correct procedure.

Click the link to be taken to the software update procedure for your audio system:

[MMCS Navigation](#)

[Display Audio](#)

[Single CD Audio](#)

SOFTWARE UPDATE PROCEDURES

The following information is updated with the new software:

- HFM part number
- HFM software version
- Gracenotes database version

!! IMPORTANT !!

Updating the software will cause the following to be erased from the HFM. You MUST notify the customer of this before updating.

- Phonebook entry data
- Pairing data
- Voice training data

Advise the customer to refer to the owner's instructions to re-enter this information.

MMCS Navigation

1. Start the engine and turn the radio ON. Wait several seconds until the OK button appears on the screen. Turn the volume down to a very low level.
2. Touch the OK button.
3. Plug the flash drive with the updated software into the USB connector on the vehicle.

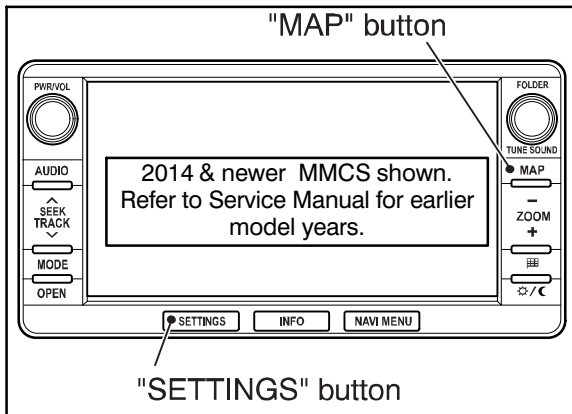

4. For 2014 and newer models: Simultaneously press and hold the MAP and SETTINGS buttons until the Service screen is displayed (approximately 3.5 seconds). For earlier model years, refer to the applicable Service Manual, Group 54A -> Chassis electrical -> Hands Free Module section.

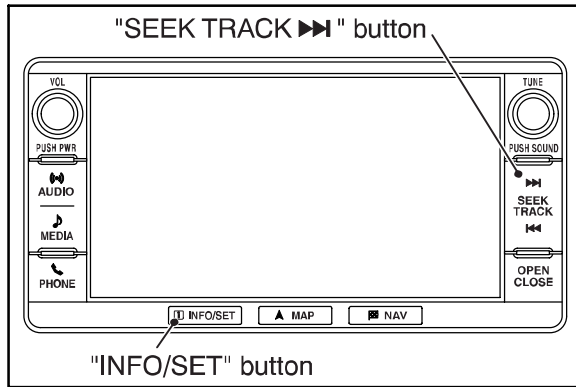

For 2016 Outlander:

Simultaneously press and hold the SEEK TRACK button (press forward arrows at top of button) and INFO/SET button until the Service screen is displayed (approximately 3.5 seconds).

!! IMPORTANT !!

Do NOT remove the flash drive or turn the engine off during the update.

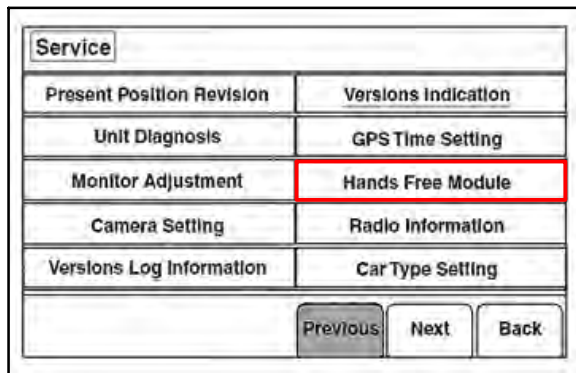

5. Touch "Hands Free Module."

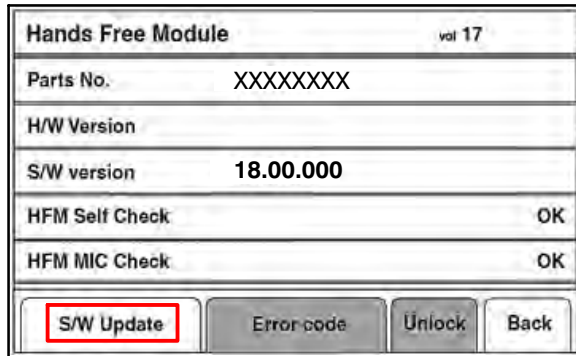

6. If update software is available the "S/W Update" button is displayed. Touch the button to continue.

If the "S/W Update" button is not displayed:

- The module is at the latest software version.
- The software on the flash drive is invalid or missing.
- Some flash drives are not compatible with this procedure, even though formatted to FAT 32. Obtain a flash drive from a reputable, quality brand and retry.

Recheck the software is present on the drive and download again if necessary.

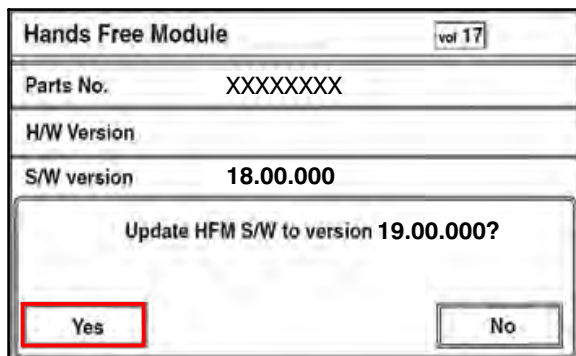

7. Touch the "Yes" button.

NOTE: The update version (19.00.000) may not be displayed during this procedure. If this occurs, touch the "Yes" button to continue. It will display when the system is rebooted.

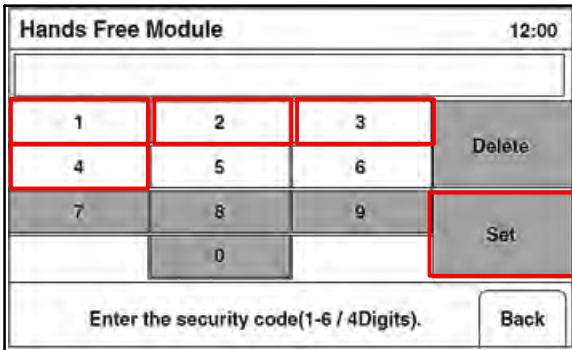

8. The Security Code Input screen is displayed. Enter the 4 digit code (1, 2, 3, 4) by touching the buttons, then touch Set.

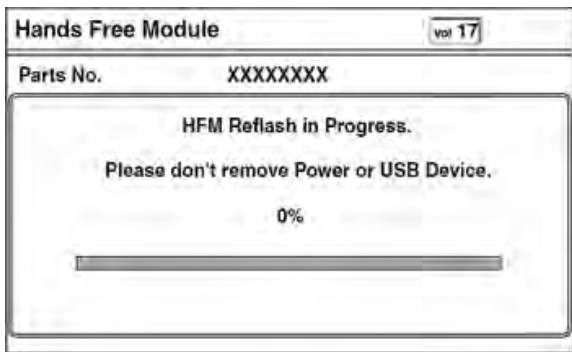

9. If you entered the correct code, a progress screen will display.

NOTE: This may take several minutes.

!! IMPORTANT !!

- Do NOT remove the flash drive.
- Do NOT turn the power off.

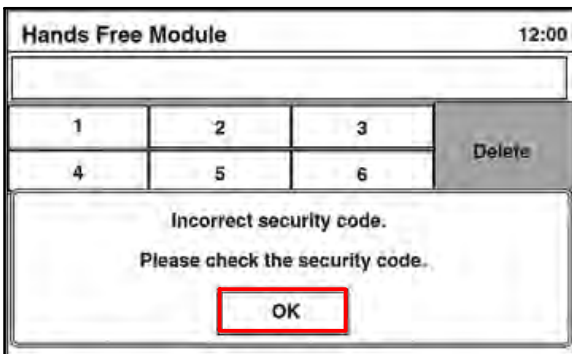

If an Incorrect Security Code screen is displayed, touch "OK."

The display will return to the Security Code Input screen (step 8).

NOTE: You must wait 5 minutes to re-enter the code.

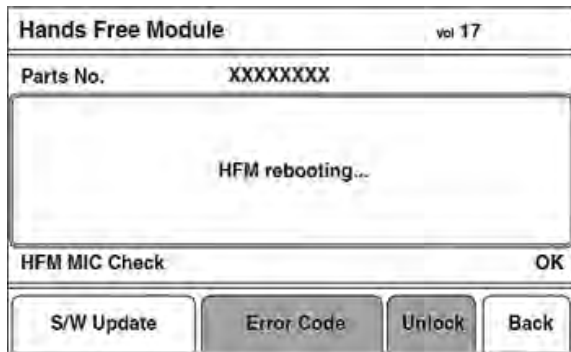

10. Do NOT press any audio control buttons while this screen is displayed.

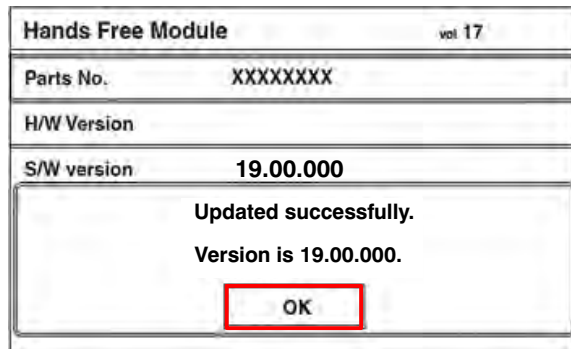

11. This screen will display if the HFM is updated successfully.

NOTE: The update version (19.00.000) may not be displayed during this procedure. If this occurs, touch the “Yes” button to continue. It will display when the system is rebooted.



12. Confirm the software version is 19.00.000.

13. Touch the Back button to return to the “Service” menu.

14. From the “Service” menu, touch the Back button to exit.

NOTE: If the new software version does not display, go back to Service mode after exiting (refer to step 4 at the beginning of this update procedure).

15. If the software update is unsuccessful:
 - a. Turn OFF the engine.
 - b. Redo step 3: Plug the flash drive with the updated software into the USB connector, then return to step 3

!! IMPORTANT !!

Do NOT remove the flash drive or turn the engine off during the update.

- c. Start the engine and turn the radio ON. Wait several seconds until the OK button appears on the screen. Turn the volume down to a very low level.
- d. Touch the OK button when it is displayed.
- e. The update process will start automatically. Wait 10 minutes.
- f. Redo step 4: Simultaneously press and hold the MAP and SETTINGS buttons until the Service screen is displayed (approximately 3.5 seconds) (2016 Outlander: hold SEEK TRACK and INFO/SET buttons).
- g. Redo step 5: Touch “Hands Free Module.”
- h. Redo step 13: Confirm the software version is 19.00.000.
- i. Redo step 14: Touch the Back button to return to the “Service” menu.
- j. Redo Step 15: From the “Service” menu, touch the Back button to exit.
- k. If the software fails to update after performing step 15a — 15i, try a USB flash drive from a different manufacturer. If the software still fails to update, replace the Hands Free ECU.

NOTE: If replacing the Hands Free ECU, you MUST call Visteon Corporation (previously Johnson Controls, Inc./JCI) at 888-702-4100 to obtain a case number, which must be entered on the warranty claim. (Does not apply to Mirage with MMES or port/dealer installed navigation system.)

16. Check the HFM version and update to 19.00.000 if necessary.

Display Audio

1. Start the engine and turn the radio ON. Wait several seconds until the radio begins playing. Turn the volume down to a very low level.
2. Plug the flash drive with the updated software into the USB connector.

!! IMPORTANT !!

Do NOT remove the flash drive or turn the engine off during the update.

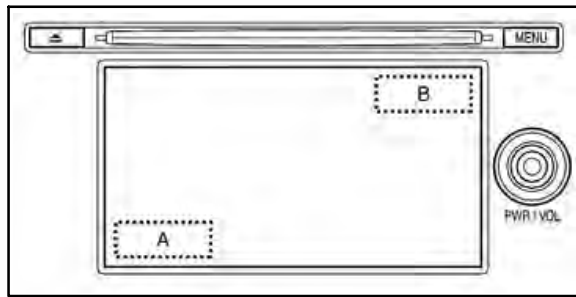

3. Press and hold the MENU button. While holding it, touch area "A," then touch and hold area "B" of the screen. The Service screen will display after 2 seconds. Release the MENU button.

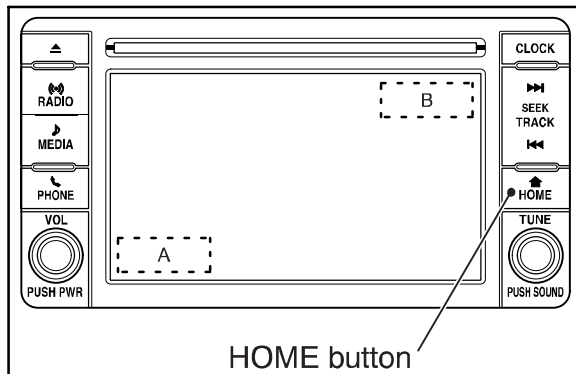

For 2016 Outlander: Press the HOME button instead of MENU.

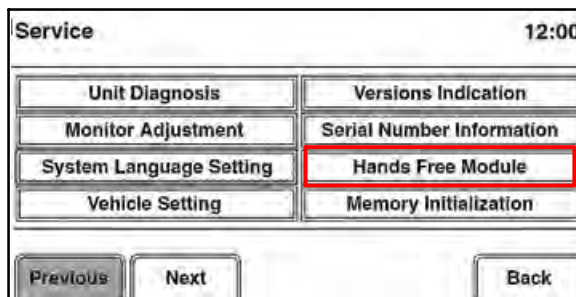

4. Touch "Hands Free Module."

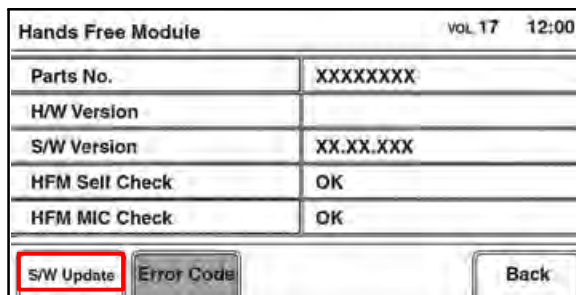

5. If update software is available the "S/W Update" or "S/W" button becomes "active." Touch the button to continue.

NOTE: Display may be different than shown, depending on model.

If the "S/W Update" (or "S/W") button is not displayed:

- The module is at the latest software version.
- The software on the flash drive is invalid or missing.

Recheck the software is present on the drive and download again if necessary.

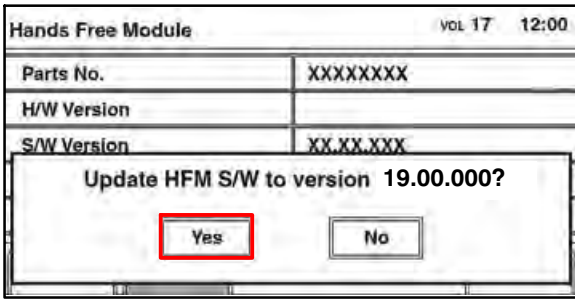

6. Touch the “Yes” button.

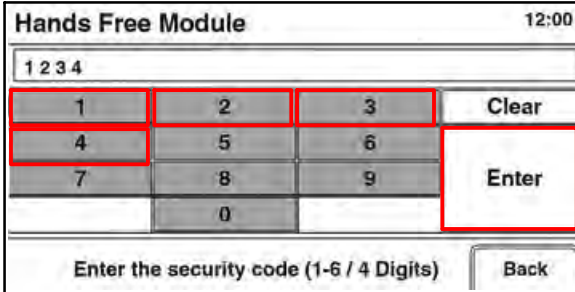

7. The Security Code Input screen is displayed. Enter the 4 digit code (1, 2, 3, 4) by touching the buttons, then touch “Enter.”

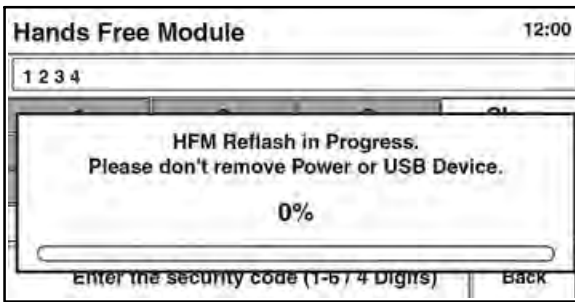

8. If you entered the correct code, a Progress screen will display.

NOTE: This may take several minutes.

!! IMPORTANT !!

- Do NOT remove the flash drive.
- Do NOT turn the radio or ignition switch OFF.

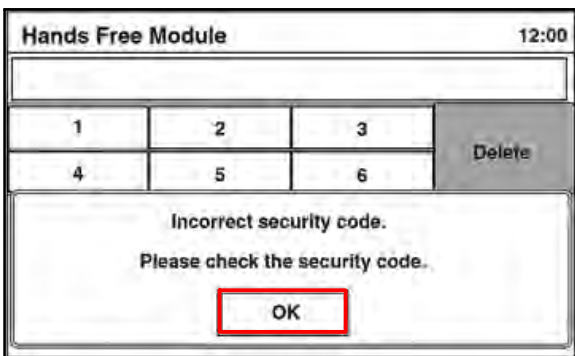

If an “Incorrect security code” was entered, this screen will display. Touch “OK.”

There are two causes for failure:

- The update takes more than 10 minutes.
- An error message is shown.

If this occurs, go to step 16.

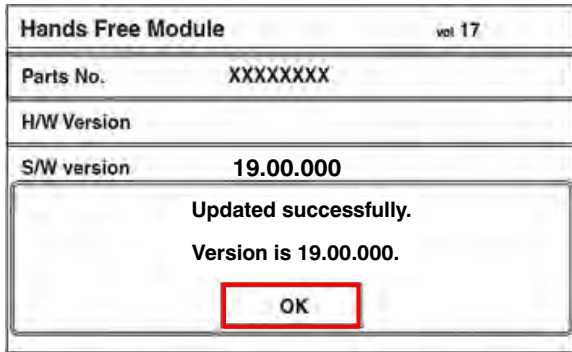

9. If the software update is successful, the system will restart and this screen will display.

Confirm Version 19.00.000

10. Touch OK to return to the Hands Free Module screen.

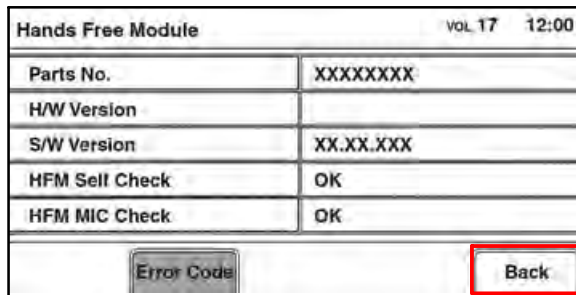

11. Confirm Version 19.00.000 is displayed in the S/W Version field.

12. Touch the Back button to return to the Service screen.

13. Touch the Back button to exit the Service screen.

14. Remove the USB flash drive.

15. Turn the ignition switch to OFF.

16. If the software updated is unsuccessful:

- a. Turn OFF the engine.
- b. Redo step 2: Plug the flash drive with the updated software into the USB connector.

!! IMPORTANT !!

Do NOT remove the flash drive or turn the engine off during the update.

- c. Redo step 1:
 1. Start the engine and turn the radio ON. Wait several seconds until the OK button appears on the screen. Turn the volume down to a very low level.
 - d. Touch the OK button when it is displayed.
 - e. The update process will start automatically. Wait 10 minutes.
 - f. Redo step 3: Press and hold the MENU button. While holding it, touch area “A,” then “B” of the screen. The Service screen will display after 2 seconds. Release the MENU button.
 - g. Redo step 4: Touch “Hands Free Module.”
 - h. Redo step 11: Confirm the software version is 19.00.000.
 - i. Redo step 12: Touch the Back button to return to the “Service” menu.
 - j. Redo Step 13: From the “Service” menu, touch the Back button to exit.
17. If the software fails to update after performing step 16a — 16i, try a USB flash drive from a different manufacturer. If the software still fails to update, replace the Hands Free ECU.

NOTE: If replacing the Hands Free ECU, you MUST call Visteon Corporation (previously Johnson Controls, Inc./JCI) at 888-702-4100 to obtain a case number, which must be entered on the warranty claim. (Does not apply to Mirage with MMES or port/dealer installed navigation system.)

18. Check the HFM version and update to 19.00.000 if necessary.

Radio and CD Player (single CD or CD Changer type)

1. Start the engine and turn the radio ON. Wait several seconds until the radio begins playing. Turn the volume down to a very low level.
2. Plug the flash drive with the updated software into the USB connector.

!! IMPORTANT !!

Do NOT remove the flash drive or turn the engine off during the update.

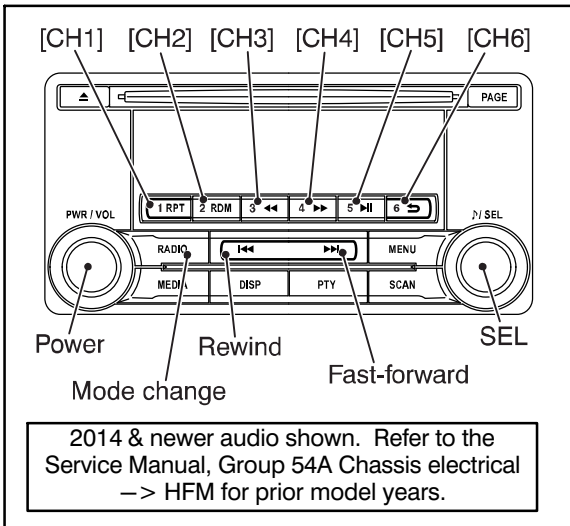

3. Press the "Power" button to turn the radio off.
4. For 2014 and newer models, press the following control buttons in order within 60 seconds of step 1.

NOTE: On 2010 – 2013 models the buttons may be in different locations than shown in the illustration, but the same process is used. For more details, refer to the applicable Service Manual, Group 54A -> Chassis electrical -> Hands Free Module section.

- (1) CH1 preset button
- (2) Rewind (I◀)
- (3) Fast-forward (▶I)
- (4) CH4 preset button

5. "DIAG MODE" is displayed. Turn the "SEL" button clockwise to display "HFM DIAG." When the "SEL" button is pressed while "HFM DIAG" is displayed, "HFM DIAG TOP" is displayed.

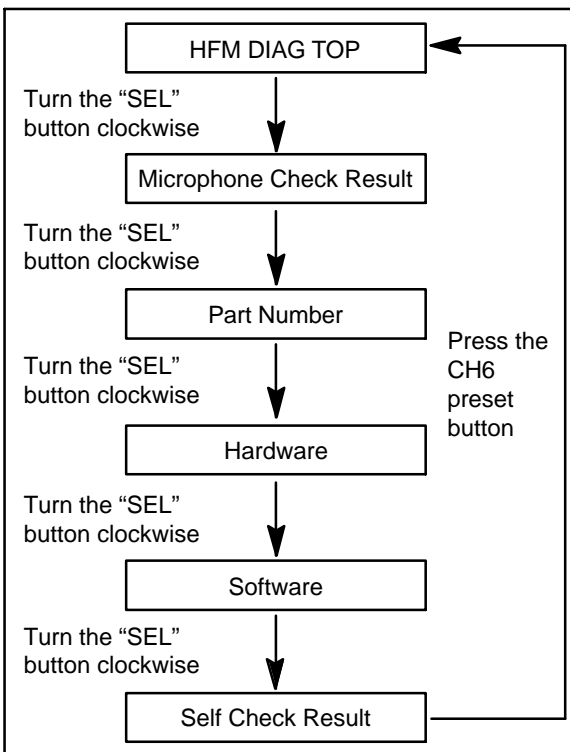

6. Confirm the software version as follows: Turn the "SEL" button clockwise to display the software version. The Software Version should be less than Ver. 19.00.000
7. Press the CH6 preset to return to "HFM DIAG TOP" after confirming the S/W version
8. With "HFM DIAG TOP" displayed, press the SEL button. If the system recognizes there is a software update to be applied, "Delete HFM" will be displayed.
9. The radio display will change to "CODE."
10. Press in order: CH1 preset, CH2 preset, CH3 preset, CH4 preset

If entered correctly, the update starts automatically.

NOTE: This may take several minutes. Do NOT press any more buttons and do NOT turn the engine off.

11. If the update is successfully completed, the system will reboot. When "Update Comp" is displayed, press the CH6 preset to return to "HFM DIAG TOP."

12. Confirm the software version is now 19.00.000.
NOTE: Turn the SEL button clockwise until S/W 19.00.000 is displayed.
13. Press the POWER button to exit DIAG mode and complete the update.
14. If the software fails to update, turn off the engine, remove the flash drive and reinsert it, turn the ignition switch to the ON position. The update process will start automatically.
15. Wait 10 minutes, then perform steps 3 through 6 again.
16. If the software still fails to update, try a USB flash drive from a different manufacturer. If the software still fails to update, replace the Hands Free ECU.
NOTE: If replacing the Hands Free ECU, you MUST call Visteon Corporation (previously Johnson Controls, Inc./JCI) at 888-702-4100 to obtain a case number, which must be entered on the warranty claim. (Does not apply to Mirage with MMES or port/dealer installed navigation system.)
17. Check the HFM version and update to 19.00.000 if necessary.

WARRANTY INFORMATION

This bulletin is supplied as technical information only and is not an authorization to repair. If an affected vehicle is reported with the described condition, diagnose the condition, repair as described in this TSB and submit a normal warranty claim.

HFM Software Update

Nature Code: 59D

Cause Code: 270

Labor Operation No.: 547047 KN

Time Allowance: 0.5 hr.

Warranty Coverage: **Basic** Coverage, 3/36 or 5/60 depending on model.*

* 3/36 applies to Lancer Evolution, Lancer Ralliart, and i-MiEV.