



# TEAM TIP

— Confidential and Proprietary —

Release Date: July 23, 2024

# SLI

Communication #: T-24-07-01

Expiration Date: No Expiration Date

Model Year(s): 2020–2024

**VERSION: R01 (July 23, 2024)**

## IMPORTANT

If you are working with a printed copy, please verify you have the most current version of this document.

Revision	Release Date	Update
R01	07/23/2024	Initial Team Tip Release

## SUBJECT: ALTERNATOR CONNECTOR

### CONCERN

Polaris has received an increasing number of claims for vehicles not charging. Testing of returned alternators indicates that the alternator was not the root cause and did not require replacement.

### POTENTIAL CAUSE



The terminal of the excitation wire may become opened, damaged, or pushed back during installation of the connector to the alternator, resulting in the alternator not charging intermittently.

### TROUBLESHOOTING & RESOLUTION

During testing for a no charge condition, closely inspect the excitation wire terminal for damage or bent tab as outlined below. If damage is found, the harness will need to be repaired. We don't yet have kits available for standard order, but if you find this condition then contact Technical Service to have a repair kit sent directly. Submit an Ask Polaris Service & Warranty Question> All Vehicle Diagnostic case. Enter "T-24-07-01" into the concern statement field.

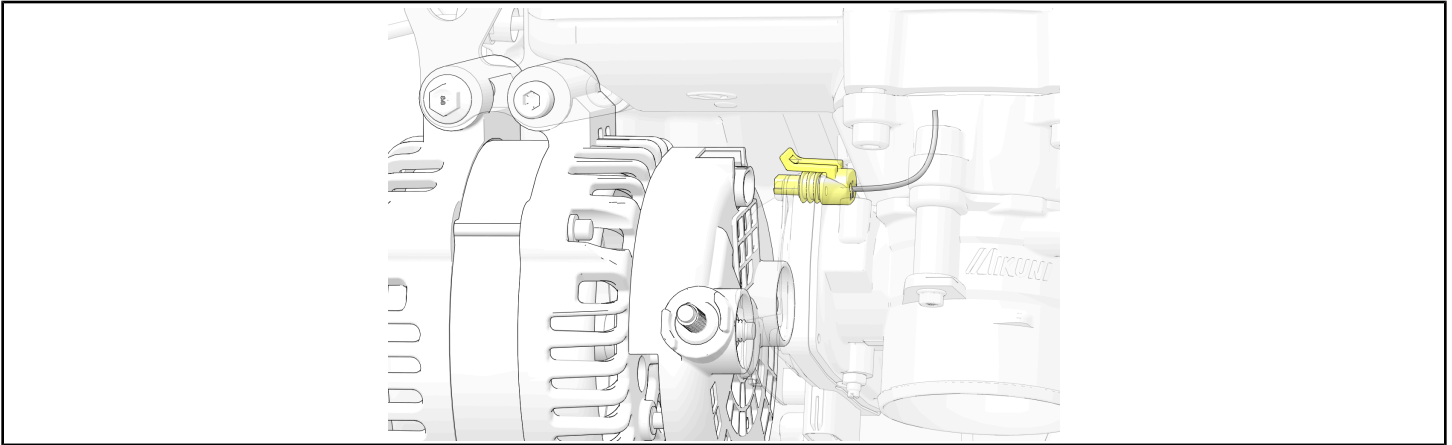
The connector is found on the upper right-hand side of the alternator. Follow the steps on the next page to properly disconnect the alternator connector.



GOOD	BAD
<p>Terminal is centered in the connector and the contact tab makes contact across the entire terminal.</p> 	<p>Terminal is damaged or contact tab is bent, leaving a gap between the top and bottom of the terminal.</p> 

## AFFECTED MODELS

MODEL YEAR	MODELS
2020–2024	All Slingshot Models

# ALTERNATOR CONNECTOR REPLACEMENT

## TOOLS REQUIRED

- Wire Cutter
- Wire Stripper
- Heat Gun

## ALTERNATOR CONNECTOR REMOVAL

### IMPORTANT

For your safety, and to ensure a satisfactory installation, perform all installation steps correctly in the sequence as shown.

1. Park vehicle on a flat surface.
2. Apply parking brake.
3. Press START/STOP button to turn vehicle OFF.
4. Remove key fob from proximity of vehicle.
5. Chock rear tire and open vehicle hood.
6. Loosen negative (-) battery terminal bolt and disconnect.

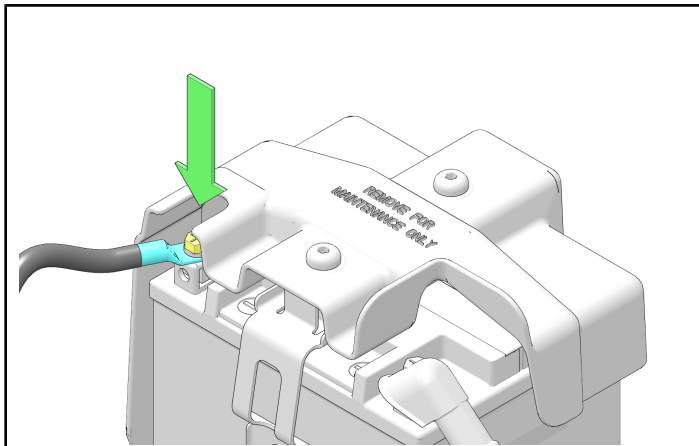

7. Disconnect the damaged alternator electrical connector from the alternator.

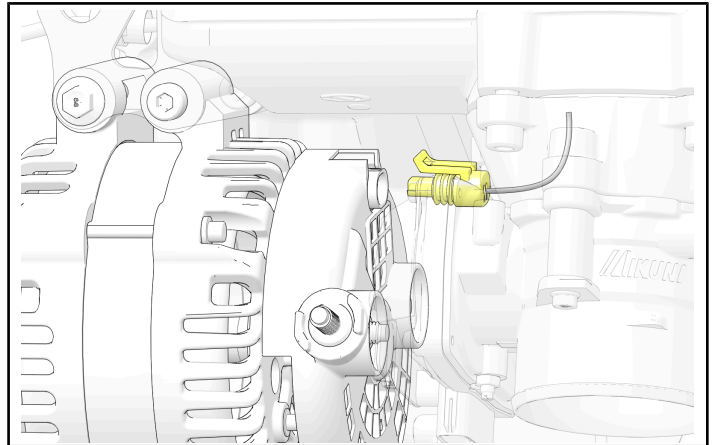

### NOTICE

If needed, remove the alternator to gain additional access to the alternator connector. The belt will require replacement. Reference the service manual for instructions.

8. Using a Wire Cutter, cut the alternator connector wire approximately 2 inches from the end of the connector.

### MEASUREMENT

**2 in (51 mm)**

9. Using a Wire Stripper, remove approximately 1/2 inch of insulation from the alternator wire.

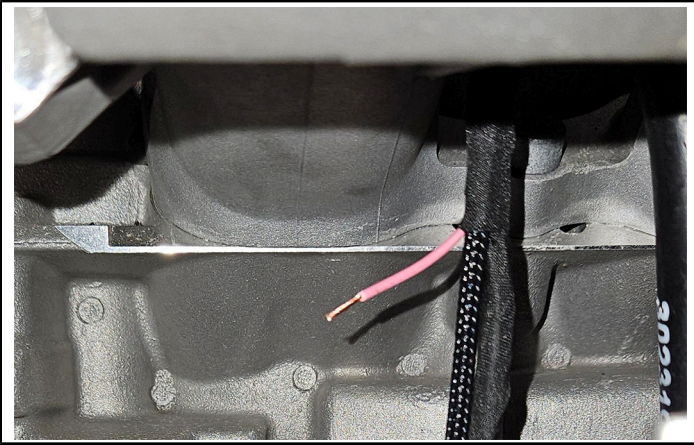

**MEASUREMENT**

**1/2 in (12 mm)**

10. Using a Wire Cutter, cut the NEW alternator connector wire approximately 3 inches from the end of the connector.

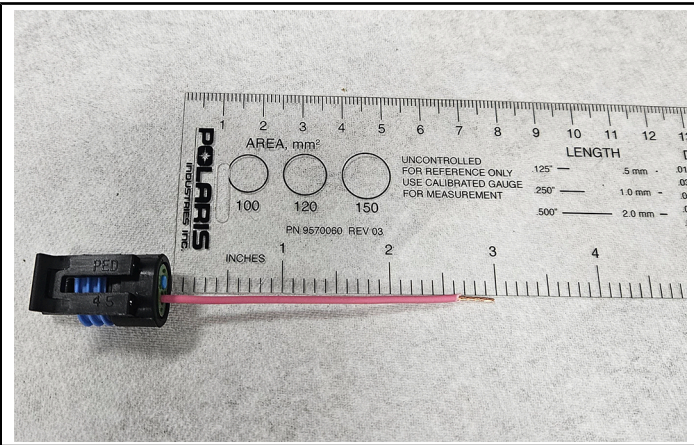

**MEASUREMENT**

**3 in (76 mm)**

11. Using a Wire Stripper, remove approximately 1/2 inch of insulation from the NEW alternator connector wire.

**MEASUREMENT**

**1/2 in (12 mm)**

## ALTERNATOR CONNECTOR INSTALLATION

1. Insert the new connector wire and solder sleeve onto the engine harness, overlapping the bare wire under the solder.

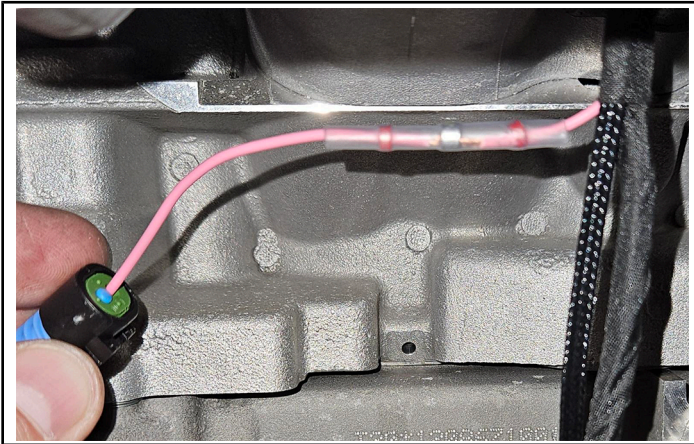

### IMPORTANT

Make sure that the wire ends overlap under the metal solder band.

2. Using a heat gun, apply heat to the outer edges of the solder sleeve and then move to the center solder. Apply heat until the solder melts into the wires.



### IMPORTANT

Do not use a torch or open flame to secure the solder sleeve. Damage to the wiring may occur.

### STOP!

Let solder cool to room temperature before proceeding.

3. Test the repair by giving the wires on each side of the repair a slight tug.

### NOTICE

If alternator was removed, install alternator using instructions from the Service Manual.

4. Connect the alternator electrical connector.

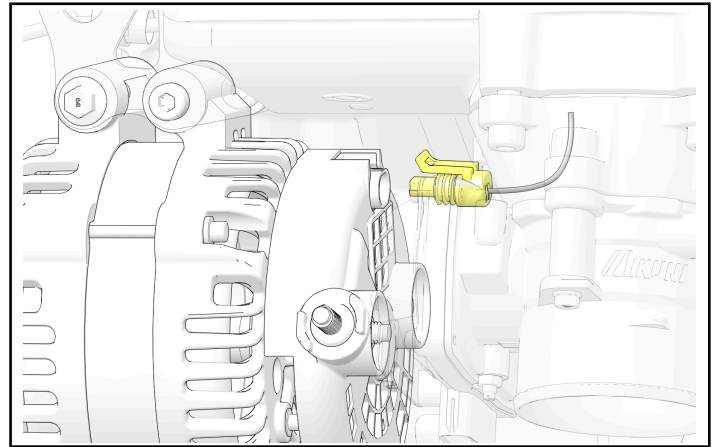

5. Install negative (-) cable to the battery and torque terminal bolt to specification.

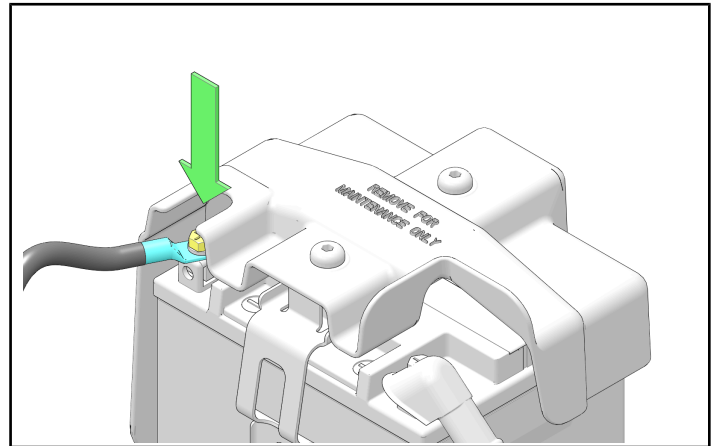

### TORQUE

Negative Battery Terminal:  
**40 in-lbs (4.5 N·m)**

6. Turn the key to the ON position, start the engine, and make sure that the vehicle powers up properly. In the gauge, verify that the battery voltage is greater than 14 Volts. Make sure there are no MILs or warning lights illuminated.

\*External Email\* Think Before You Click.



**Date:** July 23, 2024  
**ATTN:** All Service Personnel  
**Subject:** Team Tip T-24-07-01 Released

### Team Tip T-24-07-01

#### CONCERN

Polaris has received an increasing number of claims for vehicles not charging. Testing of returned alternators indicates that the alternator was not the root cause and did not require replacement.

#### POTENTIAL CAUSE

The terminal of the excitation wire may become opened, damaged, or pushed back during installation of the connector to the alternator, resulting in the alternator not charging intermittently.

#### TROUBLESHOOTING & RESOLUTION

During testing for a no charge condition, closely inspect the excitation wire terminal for damage or bent tab as outlined below. If damage is found, the harness will need to be repaired.

We don't yet have kits available for standard order, but if you find this condition then contact Technical Service to have a repair kit sent directly. Submit an Ask Polaris Service & Warranty Question> All Vehicle Diagnostic case. Enter "T-24-07-01" into the concern statement field.

Review the Team Tip for more information.

[View T-24-07-01 Team Tip](#)

### Affected Units

2020-2024 Slingshot

Please contact Polaris Service by phone at 800-330-9407 or through Ask Polaris with any questions or concerns.

Thank you for your attention.

Sincerely,

- Polaris Service

© 2024 Polaris Industries Inc. | 2100 Highway 55, Medina, MN 55340