

**Oil Leakage in the Area of the Upper Part of the Oil Pan and Crankcase: Checking Return Seal on Upper Part of Oil Pan and Replacing if Necessary (91/24)**

Vehicle Type: **718 Cayman GTS 4.0 (982) / 718 Boxster GTS 4.0 (982) / Boxster 25 years (982) / 718 Spyder (982) / 718 Cayman GT4 (982)**

Model Year: **As of 2020 up to 2024**

Equipment: 4.0-liter flat-six naturally aspirated engine

Concerns: **Oil pan return seal**

Cause: **Oil traces are detected on the oil pan on the side of the engine transmission flange.**

The leak is located in the area of the sealing point between the upper part of the engine oil pan and crankcase ⇒ *Oil leakage area -Circle-*, on green return seal ⇒ *Oil leakage area -1-* in the "window section" of the upper part of the oil pan.

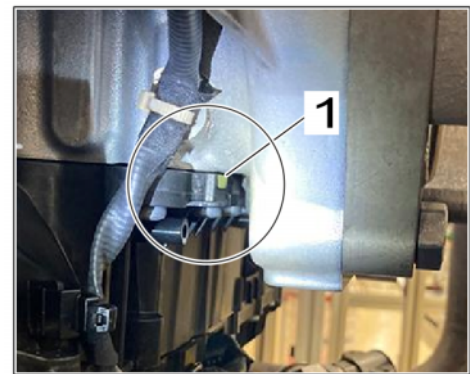

*Oil leakage area*

Action: Check the return seal in the area of the "window section" and replace it with a **new component status** if applicable.



**Information**

**Replacing the upper part of the oil pan, including the moulded seal, is not expedient** because this complaint involves a defect in the return seal in the area of the "window section" of the oil pan and not a defect in the oil pan itself.

**Required parts**

Parts Info:	Part No.	Designation – Location	Number
	OPB115111C	⇒ Seal, Black – Return line of upper part of oil pan	2 pieces

9A700828100	⇒ O-Ring 31.0 x 3.00 – Coolant pipe on controller	2 pieces
PAF013814	⇒ M14 x 18 sealing ring – Coolant drain plug	2 pieces
PAF008640	⇒ O-Ring 10.00 x 3.5 – Upper part of oil pan	2 pieces
OPB115625A	⇒ Oil pan sealing ring – Lower part of oil pan	2 pieces
95810380100	⇒ Screw plug on oil pan	1 piece

Material: **Required materials** (usually already available in the Porsche Center):

Part No.	Designation – Application point / additional designation	Quantity
00004320593	⇒ Lubricating grease (100 g/ 3.52 oz tube), Klüberplus gel – O-rings	As required
00004330516	⇒ Coolant (20 l/ 5.28 gal container) – Cooling system	As required
...	⇒ Engine oil, C40 standard – EXXON MOBIL 1 ESP X3, OW-40	As required

## Required Tools

- Tools:
- **P90999 - PIWIS Tester 4**
  - Battery charger with a current rating of **at least 90 A**, e.g. **VAS 5908 - 90-A battery charger**. For further information about the battery chargers to be used, see the corresponding Workshop Manual. ⇒ *Workshop Manual '270689 Charging battery and vehicle electrical system'*
  - Torque wrench, 2-10 Nm (1.5-7.5 ftlb.), e.g., **V.A.G 1783 - torque wrench, 2-10 Nm (1.5-7.5 ftlb.)**
  - Torque wrench, 20-100 Nm (15-74 ftlb.), e.g., **VAS 5820 - Torque wrench, 20-100 Nm (15-74 ftlb.)**
  - Torque wrench, 40-200 Nm (30-148 ftlb.), e.g., **V.A.G 1332A - torque wrench, 40-200 Nm (30-148 ftlb.)**
  - Cooling system service device, e.g., **VAS 531 011 - Cooling system service device**
  - Funnel, e.g., **VAS 6675A - Funnel**
  - Filling device, e.g., **9696 - Filling device**
  - Vacuum pump, e.g., **VAS 6096/2 - Vacuum pump**
  - Spring band clamp pliers, e.g. **VAS 6890 - Spring band clamp pliers**
  - Assembly tool, e.g., **T10549 - Assembly tool**

**Checking return seal on upper part of oil pan and replacing if necessary**

Work Procedure: 1 Remove rear underbody cover.  
 ⇒ *Workshop Manual '519419 Removing and installing cover for rear underbody'*



**Information**

**Oil leakage must be clearly identifiable and reproducible.**

To do this, proceed as follows:

1. Document the original complaint condition with meaningful photos.
  2. Attach documentation to PCSS line.
  3. Clean the engine and transmission thoroughly.
  4. Spray large areas of the engine and transmission with SpotCheck around the suspected leakage points.
  5. If necessary, perform a test drive with the engine oil and coolant having at least reached operating temperature.
  6. Locate the oil leakage.
  7. Produce photo documentation of the leakage point located using SpotCheck.
  8. Attach documentation to PCSS line.
- 2 Check the return seal in the area of the "window section" on the upper part of the oil pan.

Assessment		Action
(✓)	Oil leakage not in the window section or on the return seal	If the complaint is not rectified by this technical information, resume troubleshooting.  Install rear underbody cover. ⇒ <i>Workshop Manual '519419 Removing and installing cover for rear underbody'</i>  <b>End of action.</b>
(x)	Oil leakage in the window section or on the return seal	Continue with ⇒ 3.

- 3 Replace previous return seals ⇒ *Affected seals -1 and 2-* on the upper part of the oil pan with **new, black return seals with a new component status**.  
 For procedure, see: ⇒ *Workshop Manual '175019 Removing and installing oil pan (upper part)'*

**Information**

The previous component status of the return seal in green must no longer be used here.

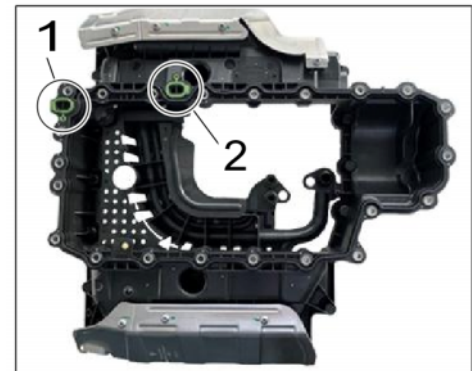

*Affected seals*

**Labor position and PCSS encryption****Information**

If necessary, additionally required working time guideline values for preparatory or follow-up actions need to be determined using the Porsche Central Service System (PCSS), depending on the equipment of the vehicle.

Labor position:

APOS	Labor operation	I No.
17510190	Checking seal on oil pan	
17510191	Checking seal on oil pan	
17501976	Removing and installing oil pan (lower part)	
17501977	Removing and installing oil pan (upper part)	
19381775	Draining and filling coolant	
19010750	Bleed the cooling system	
17011775	Draining and filling engine oil	

PCSS encryption:

Location (FES5)	17500	Oil pan
Damage type (SA4)	5043	Oil loss

**Important Notice:** Technical Bulletins issued by Porsche Cars North America, Inc. are intended only for use by professional automotive technicians who have attended Porsche service training courses. They are written to inform those technicians of conditions that may occur on some Porsche vehicles, or to provide information that could assist in the proper servicing of a vehicle. Porsche special tools may be necessary in order to perform certain operations identified in these bulletins. Use of tools and procedures other than those Porsche recommends in these bulletins may be detrimental to the safe operation of your vehicle, and may endanger the people working on it. Properly trained Porsche technicians have the equipment, tools, safety instructions, and know-how to do the job properly and safely. Part numbers listed in these bulletins are for reference only. The work procedures updated electronically in the Porsche PIWIS diagnostic and testing device take precedence and, in the event of a discrepancy, the work procedures in the PIWIS Tester are the ones that must be followed.

© 2024 Porsche Cars North America, Inc.