

- ATTENTION:**
- GENERAL MANAGER
  - PARTS MANAGER
  - CLAIMS PERSONNEL
  - SERVICE MANAGER

IMPORTANT - All Service Personnel Should Read and Initial in the boxes provided, right.

© 2024 Subaru of America, Inc. All rights reserved.



QUALITY DRIVEN® SERVICE

**SERVICE BULLETIN**

**APPLICABILITY:** 2019-24MY Ascent

**NUMBER:** 06-92-24

**SUBJECT:** Front Brake Pulsation/Squeal Diagnosis & Repair Front Brake Warranty Extension

**DATE:** 07/31/24

**INTRODUCTION:**

In the interest of customer satisfaction, Subaru of America, Inc. (SOA) is extending the New Car Limited Warranty coverage for the front brake on 2019-24 model year Ascent models to 8 years (96 months) or 150,000 miles (whichever comes first) to address cases of front brake pulsation or squealing.

In addition, this bulletin announces availability of a new diagnosis/repair procedure developed to address concerns of a squeal type sound occurring when operating the brakes. An additional tie bar component has been developed to provide added rigidity and reduce noise/vibration. The number of brake disc cooling fins has increased from 41 to 47. If a squeal type sound and/or pulsation from the front brakes is reported by the customer, follow the service procedures outlined in this bulletin.

**PRODUCTION CHANGE INFORMATION:**

The new brake components have been incorporated into vehicle production as per starting VIN **R3417029**.

**CAUTION: VEHICLE SERVICING PERFORMED BY UNTRAINED PERSONS COULD RESULT IN SERIOUS INJURY TO THOSE PERSONS OR TO OTHERS.**



Subaru Service Bulletins are intended for use by professional technicians ONLY. They are written to inform those technicians of conditions that may occur in some vehicles, or to provide information that could assist in the proper servicing of the vehicle. Properly trained technicians have the equipment, tools, safety instructions, and know-how to do the job correctly and safely. If a condition is described, DO NOT assume that this Service Bulletin applies to your vehicle, or that your vehicle will have that condition.

**Subaru of America, Inc. is ISO 14001 Compliant**

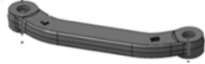

ISO 14001 is the international standard for excellence in Environmental Management Systems. Please recycle or dispose of automotive products in a manner that is friendly to our environment and in accordance with all local, state and federal laws and regulations.

*Continued...*

**PART INFORMATION:**

Part Description	Part Number	Quantity	Details
FRONT BRAKE DISC	26300XC01A	2	
TIE BAR	26261XC000	2	
MOUNTING BOLT	26208XC000	4	 OLD: 1 11/16in (42.8mm) NEW: 2 3/8 inch (60.0mm)

**NOTE:** Currently available pad kit is also necessary to complete this repair. Please refer the table below for details.

26296XC00D Pad Kit Breakdown			
Part Description	Part Number	Quantity	Details
PAD COMPLETE	N/A	1 Kit (4 Pads)	
Grease (Klüber)	N/A	1	

**IMPORTANT NOTES:**

**DO NOT** install both old and new type parts on the same vehicle. These new components **MUST** be replaced in pairs.

In cases where a vehicle has been previously equipped with a tie bar, the original tie bar is to be reused.

In cases where a vehicle is not equipped with tie bars, it is **CRITICAL** to use the new bolts (**p.n. 26208XC000**) in conjunction with the tie bars (**p.n. 26261XC000**).

*Continued...*

## SERVICE PROCEDURE / INFORMATION:

**STEP 1:** Perform a road test and confirm a brake squeal and/or pulsation condition is present. Use the table below to confirm the next course of action.

Condition	Course of Action
Front Brake Squeal Only	Proceed to Step 3
Front Brake Pulsation Only	Proceed to Step 2
Both Front Brake Squeal & Front Brake Pulsation	Proceed to Step 3

**STEP 2:** Raise the vehicle using the lift manufacturer's specified procedures. Remove both front wheels. Inspect the brake disc part numbers to confirm the brake disc version currently installed on the vehicle. See the images below for part number location.

**NOTE:** The new parts have 47 cooling fins, and the old parts have 41 cooling fins.

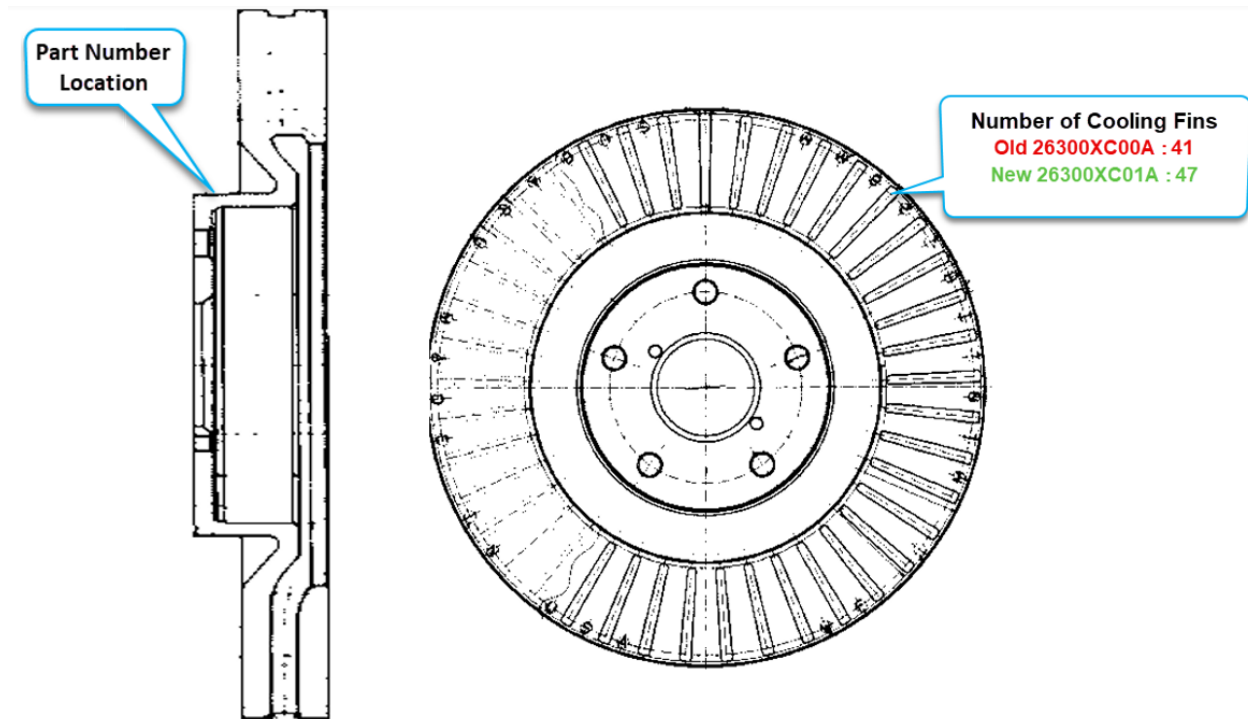

Is the vehicle currently equipped with the new brake discs?

**YES:** Resurface the brake discs using a Subaru approved brake lathe. Perform a road test and confirm there is no front brake squeal/pulsation. **IMPORTANT: ALWAYS** use an approved brake lathe. A list of approved equipment can be found on the Subaru tools and equipment site: <https://subaruretailersolutions.com/equipment/category/601>

**NO:** Proceed to Step 3.

*Continued...*

**STEP 3:** Staring at the left front wheel, remove the pad clip.

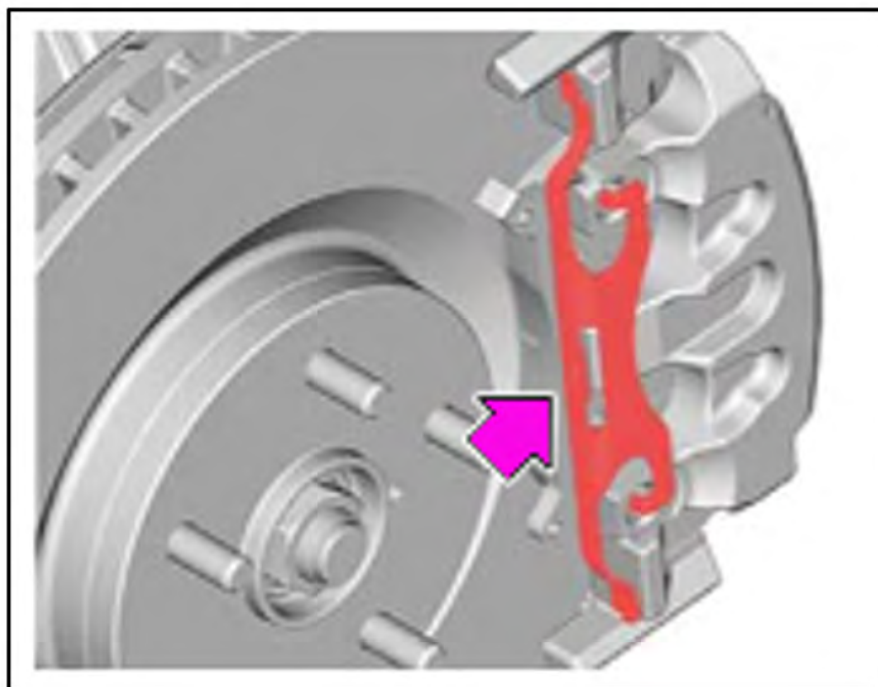

**STEP 4:** Remove both dust caps (a). Using an 11 mm allen key, remove both guide pins (b). The caliper body can then be removed.

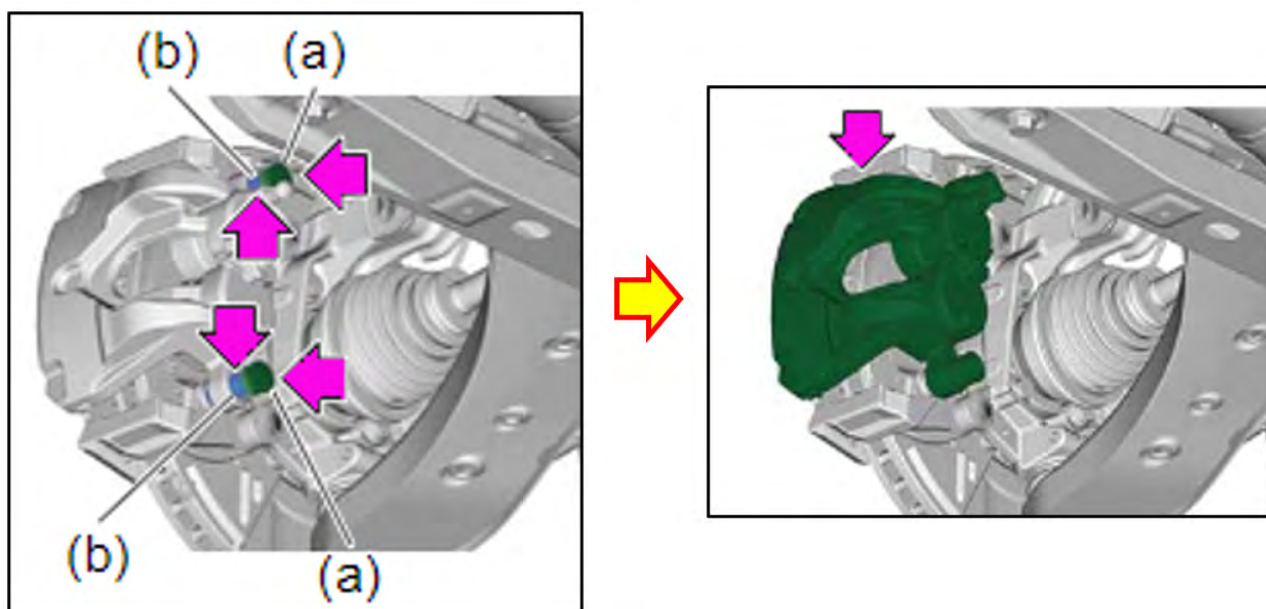

*Continued...*

**STEP 5:** Remove the inner and outer brake pad.

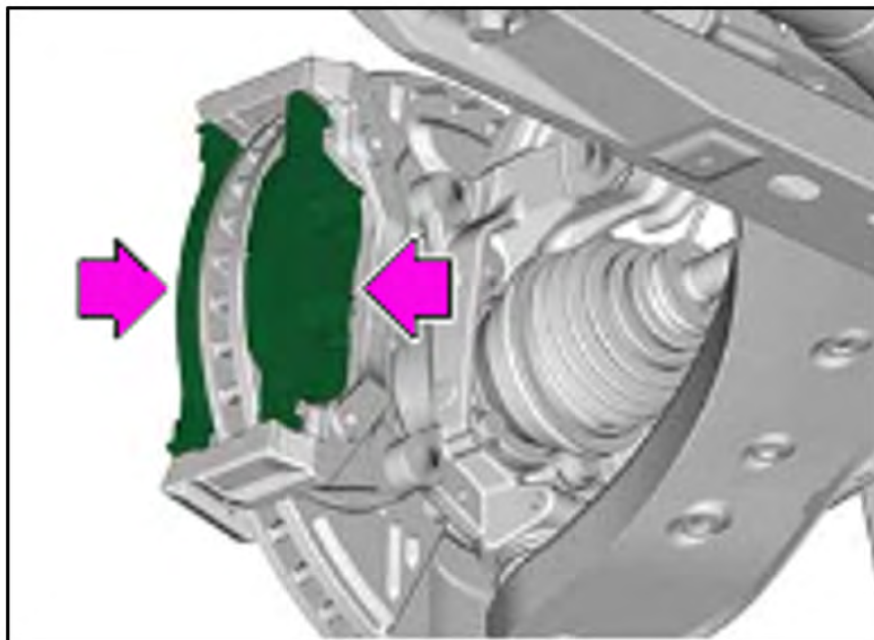

**STEP 6:** Remove the caliper bracket mounting bolts and then remove the bracket. The mounting bolts removed during this Step **MUST NEVER BE REUSED** during re-assembly. Discard the original mounting bolts. The front left brake disc can then be removed.

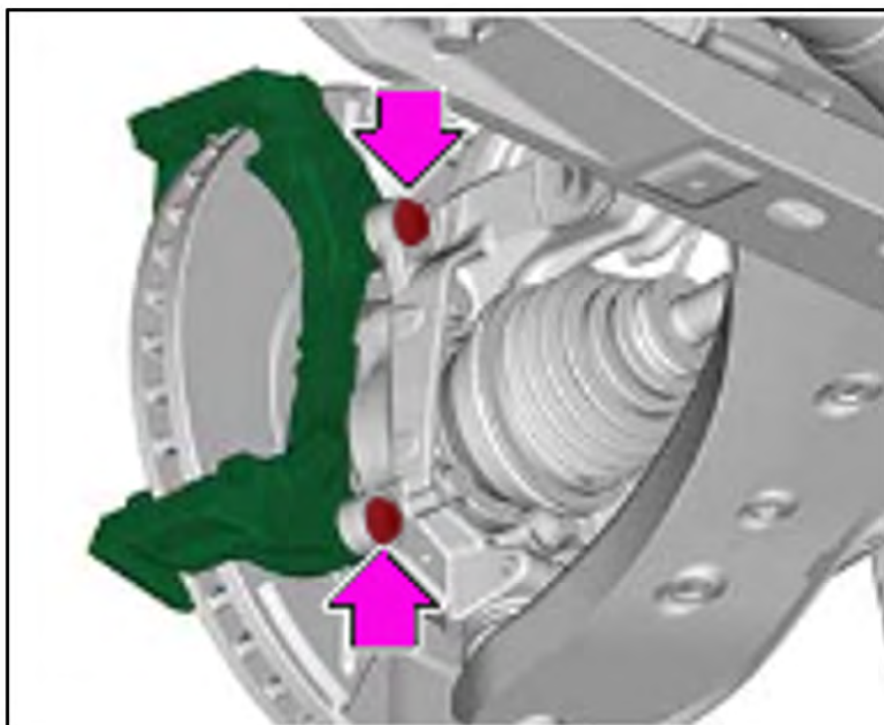

*Continued...*

**STEP 7:** Using a dial gauge, inspect for any excessive play in the axial direction of the front hub bearing. Confirm the observed measurement is below the service limit of 0.05mm (0.002 in). If the measurement exceeds the specified value, the front hub bearing will require replacement.

**\*NOTE:** Noise or judder caused by excessive play on the front hub bearing is a separate condition that is not covered under the terms of this warranty extension. Please process such repairs under normal procedures.

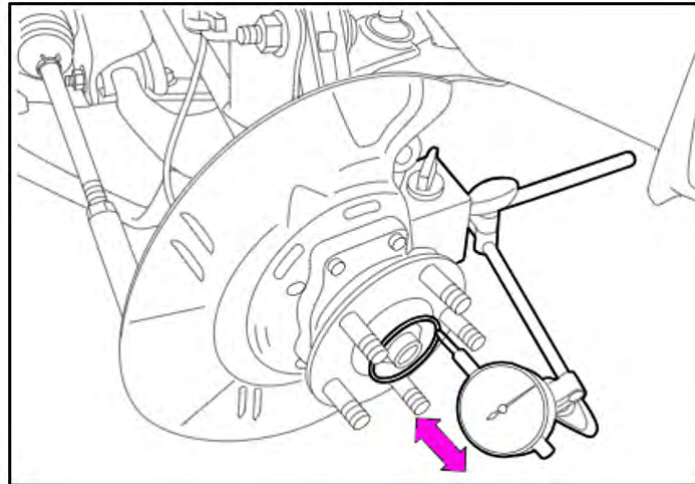

**STEP 8:** Install the new brake disc. Secure the disc to the hub using the five lug nuts in conjunction with matching suitable washers. Torque the lug nuts in a star pattern to **120 Nm (88.5ft-lb)**. Using a dial gauge, inspect the outer brake disc runout. Confirm the observed measurement does not exceed 0.05 mm (0.002 inch). If the measurement exceeds the specified value, remove the brake disc from the hub. Using the wheel studs as a guide, rotate the disc clockwise one wheel stud position and reinstall the brake disc. Inspect the runout using the procedures described above. The brake disc position can be rotated up to 4 more times to confirm the position with the least amount of runout. Install the brake disc at this position. In rare cases of the measurement not reading within specification after the five position inspection, exchange the brake disc the other side of the vehicle and repeat the measurement. If the measurement continues to produce results out of specifications, replace the brake disc.

**IMPORTANT:** For best accuracy, the runout measurement should be taken 10mm from the outer circumference of the brake disc. See the example image below.



*Continued...*

**STEP 9:** Apply a thin layer of the **Klüber** grease to the caliper bracket in the locations outlined in yellow specified below.

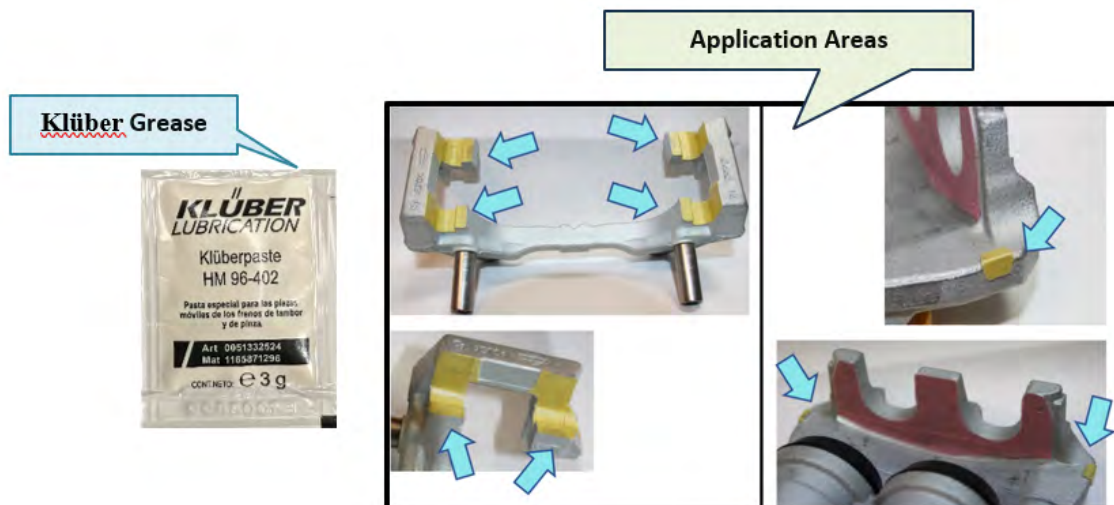

**STEP 10:** Apply a thin layer of the **Klüber** grease to the caliper in the sections specified below.

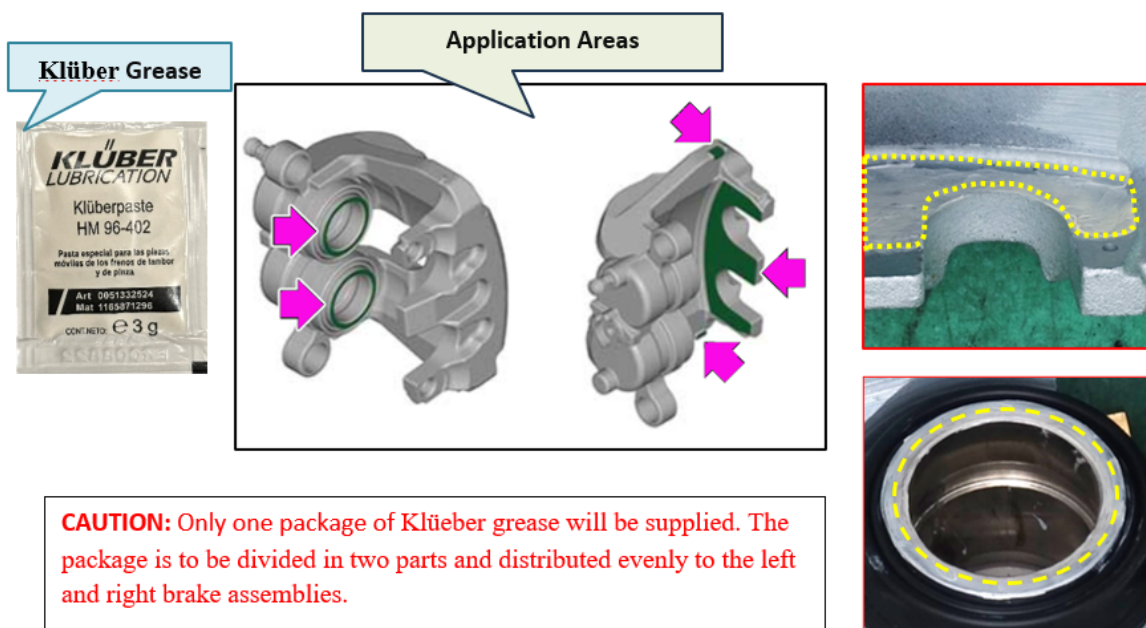

*Continued...*

**STEP 11:** Pre-assemble the new mounting bolts and the new tie bar as shown below.

**IMPORTANT:** Orientation of the tie bar is designated by **R** (Right) and **L** (Left) markings located on the outside of the tie bar casting. The tie bar is to be installed with the markings facing away from the brake disc and the correlating side marking positioned on top.

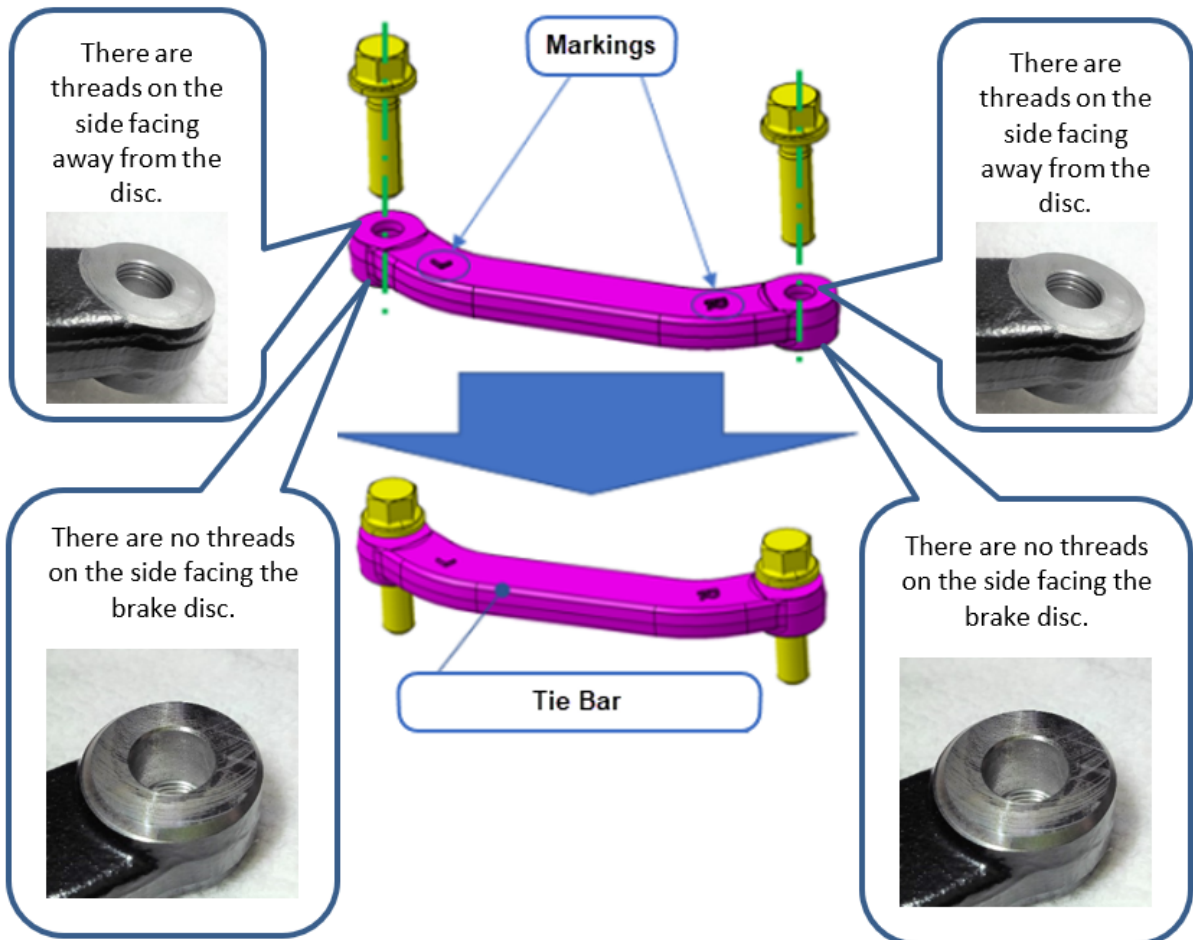
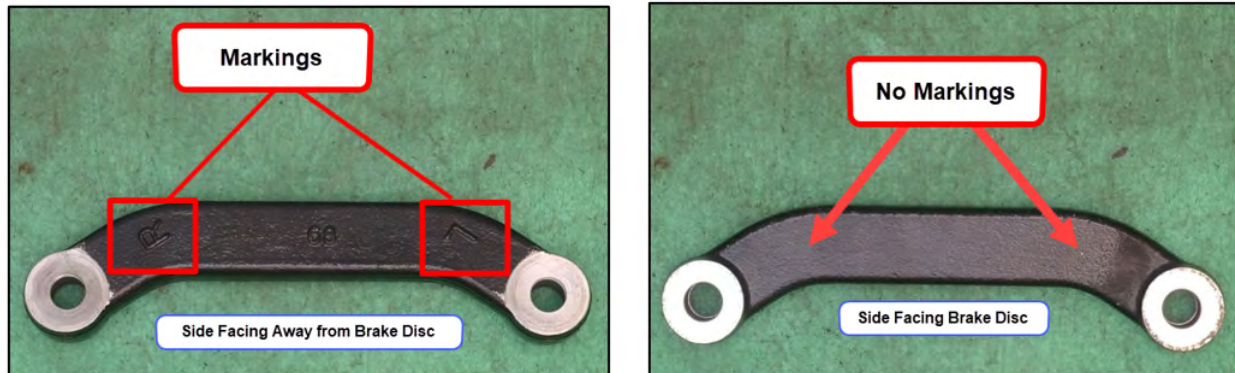

*Continued...*





The threaded ends of the tie bar help prevent the bolts from falling out during installation.

**STEP 12:** Reassemble the left front brake caliper bracket, caliper, and pads along with the tie bar and mounting bolts. Torque the mounting bolts to **142 Nm (104.7 ft-lb)**.

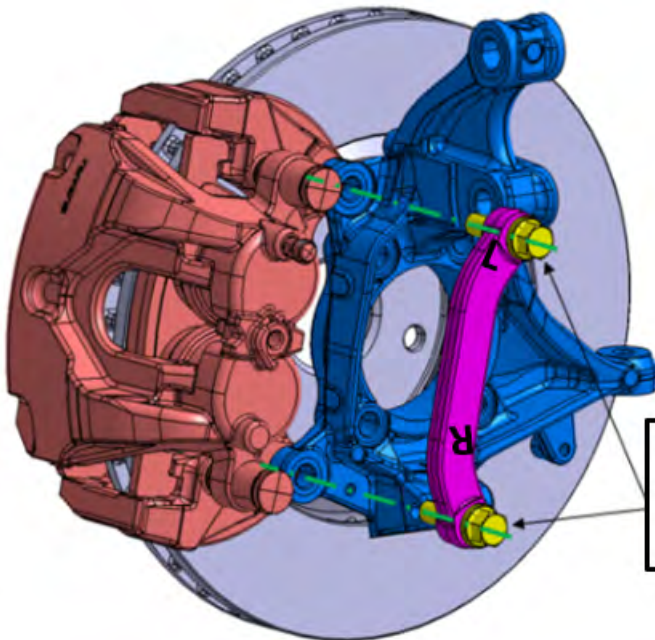

**Torque Specification:**

**142 Nm (104.7 ft-lb)**

**STEP 13:** Repeat Steps 3-12 on the right front side of the vehicle.

**STEP 14:** Reinstall the left and right front wheels and torque to **120 Nm (88.5ft-lb)**.

*Continued...*

**TORQUE SPECIFICATION REFERENCE:**

Torque Specifications	
Support Front Disc Brake	142Nm (14.5kgf-m, 104.7 ft-lb)
Caliper Body	55Nm (5.6kgf-m, 40.6 ft-lb)
Brake Hose Front	26Nm (2.7kgf-m, 19.2 ft-lb)
Bleeder Screw	17Nm (1.7kgf-m, 12.5 ft-lb)
Front Wheel	120Nm (12.2kgf-m, 88.5 ft-lb)

**DETAILS OF WARRANTY EXTENSION:**

- Upon availability of newly developed front brake pad kits, the Warranty Extension will end once all of the new parts (brake pads, rotors, and tie bars) have been installed to the vehicle.
- Effective from the date of customer notification, ALL affected vehicles, regardless of mileage and Warranty start date will be covered for these repairs for a period of one year.
- All inspections and repairs must be completed prior to the expiration of this Warranty Extension.
- Subaru is reimbursing customers who previously paid a Subaru retailer for repair and/or replacement related to this Warranty Extension due to conditions that would normally have been covered if the vehicle was still under the terms of the New Vehicle Limited Warranty. The period of the reimbursement shall be one year from the customer/dealer notification of the Warranty Extension.

**WARRANTY / CLAIM INFORMATION:**

For vehicles within the Warranty Extension and Basic New Car Limited Warranty period, this repair may be submitted using the following claim information:

Vehicles WITHOUT Any Updated Parts Previously Installed			
Labor Description	Labor Operation #	Labor Time	Fail Code
BOTH FRONT ROTOR R&R AND TIE BAR INSTALL. (Includes brake pad R&R.)	A511-086	1.0	QDE-10
BOTH FRONT ROTORS R&R AND MEASURE RUNOUT 5 POSITIONS (ONE SIDE) Includes brake pad R&R.	A511-286	1.1	
BOTH ROTORS R&R AND MEASURE RUNOUT 5 POSITIONS (BOTH SIDES) Includes brake pad R&R.	A511-386	1.2	

<b>Vehicles Previously Equipped WITH Updated Brake Rotors &amp; Tie Bars</b>			
<b>Labor Description</b>	<b>Labor Operation #</b>	<b>Labor Time</b>	<b>Fail Code</b>
FRONT BRAKE PAD SET R&R	A510-086	0.5	QDE-10
BOTH FRONT BRAKE ROTORS RESURFACE ON VEHICLE (Includes brake pad R&R.)	A510-486	1.0	
BOTH FRONT BRAKE ROTORS REPLACE (Includes brake pad R&R.)	A510-586	1.0	
BOTH FRONT ROTORS R&R AND MEASURE RUNOUT 5 POSITIONS (ONE SIDE) Includes brake pad R&R.	A510-686	1.1	
BOTH ROTORS R&R AND MEASURE RUNOUT 5 POSITIONS (BOTH SIDES) Includes brake pad R&R.	A510-786	1.2	

**IMPORTANT REMINDERS:**

- SOA strongly discourages the printing and/or local storage of service information as previously released information and electronic publications may be updated at any time.
- Always check for any open recalls or campaigns anytime a vehicle is in for servicing.
- Always refer to STIS for the latest service information before performing any repairs.

*Continued...*



PO Box 9103  
Camden, NJ 08101-9877  
844-373-6614  
www.subaru.com

**July 2024**

**IMPORTANT NOTICE:**

**Warranty Extension for Ascent Front Brake Judder/Squeak on certain  
2019 to 2024 MY Ascent Vehicles Manufactured PRIOR to January 11<sup>th</sup>, 2024**

**Dear Subaru Owner:**

As part of Subaru of America's dedication to customer satisfaction, Subaru of America, Inc. (SOA) is announcing a warranty extension to the front brakes on 2019-2024 MY Ascent Vehicles Manufactured PRIOR to January 11<sup>th</sup>, 2024.

Affected vehicles are equipped with front brakes that may, under certain conditions, exhibit a squeak or squeal type noise or a judder type feel when coming to a stop.

**NOTE: No action is required by you to receive the benefit of this warranty extension. The extension has been automatically applied to your vehicle.**

**If your vehicle is operating as expected, you do not need to take your vehicle to a Subaru retailer for repairs.**

**ASCENT FRONT BRAKE WARRANTY EXTENSION COVERAGE**

For qualifying repairs, this extension covers the costs of diagnosis and replacement of the front brake components—brake pads, rotors, and tie bars with bolts—with newly developed parts. The extended warranty coverage will end once the newly developed parts have been installed.

Most parts are available now, with the new brake pads expected to arrive at your Subaru Retailer by December 2024. In the interim, this extended warranty will cover any qualifying repairs using currently available components.

The coverage period extends the New Vehicle Limited Warranty as it applies to the front brake components to eight (8) years or one hundred and fifty thousand (150,000) miles, whichever occurs first, or until the newly developed parts have been installed in your vehicle.

Inspections or repairs under this coverage period must be completed prior to the expiration of that eight (8) year period, or before 150,000 miles, whichever comes first, calculated from your vehicle's in-service date.

Effective from the date of this customer notification, ALL affected vehicles regardless of the vehicle's mileage and warranty start date will be covered for these repairs for a period of one (1) year.

**If you have questions about this notice, please contact the Ascent Front Brake Warranty Extension Hotline at 877-551-7149. Additional information can be found online at: [subaruclaims.autosolutionsteam.com](http://subaruclaims.autosolutionsteam.com)**

## **REIMBURSEMENT ELIGIBILITY**

- You may be eligible for reimbursement if you paid to have your Ascent's front brakes repaired or replaced related to this Warranty Extension after the expiration of the original Basic New Car Limited Warranty period, but before this announcement of this warranty extension period of Eight (8) years/ 150,000 miles. The period of reimbursement shall be One (1) year from customer/ retailer notification of this warranty extension.
- You must have paid an out-of-pocket expense for a repair that would have been covered had it occurred during the warranty coverage period. This includes any deductible expense or partial reimbursement for repairs.
- If you have been previously reimbursed by SOA or one of its retailers for partial coverage of this repair, only the portion that has not been reimbursed is eligible for reimbursement.
- You are not eligible to recover any repair costs previously reimbursed or paid for by any third-party, including Subaru Added Security, other extended warranty providers, or an authorized Subaru retailer.

## **TO APPLY FOR REIMBURSEMENT**

Please complete the claim form online at [subaruclaims.autosolutionsteam.com](http://subaruclaims.autosolutionsteam.com) and attach the required documentation listed below:

- **Attach a copy of the receipt or invoice for the repair.** A copy of the repair invoice or work order showing repair will meet this requirement. The invoice must show your vehicle model, vehicle identification number (VIN), the name and address of the facility that completed the repair, the cost of the repair (parts and labor), and the date the work was completed.
- **Attach proof of payment**, such as a copy of the canceled check, bank statement, cash receipt, or credit card receipt showing what you paid for the repair.
- **You Must Submit your application for reimbursement within six (6) months from the date of this letter.**

If you prefer to apply for reimbursement by mail, please send a completed *Claim Reimbursement Form* and copies of the required documentation listed above to:

**Subaru of America Inc.  
Warranty Extension  
2670 Executive Dr  
Indianapolis, IN 46241**

Please allow 45 days for the reimbursement to be processed. Failure to include proper documentation may delay your reimbursement.

Sincerely,

Subaru of America, Inc.

*Subaru of America, Inc. participates in the “Print One Plant One” program. With each piece of outbound mail or print, this partnership plants a native plant at a restoration site to help offset our organization’s carbon footprint and reduce our impact on the environment.*

