

# SS 3152-FTL New Cascadia Lytx SF500 intermittent video feed issues



## **Applicable Vehicles**

This Service Solution applies to New Cascadia vehicles built with data code (3ZS-015- LYTX SF500 DRIVECAM SYSTEM, FACTORY/CTS INSTALLED).

## **Symptoms**

Personnel monitoring video from the Lytx SF500 system, can experience intermittent loss of video feed. Since this issue does not affect the function of the vehicle and cannot be viewed by technicians servicing the unit, customers would need to be directed to this Service Solution either by Lytx or personnel monitoring the video feed.

## **Issue**

In some cases, cables/wires do not get correctly secured resulting in wear/damage on the connector, looped and or twisted wires, that can result in pinched or damaged wiring.

## **Solution**

When a repair facility is referred to this Service Solution either by Lytx or a customer monitoring their video feed, this solution will provide guidance for properly addressing areas of concern.

**General information:**

Since technicians working on the Lytx SF500 Drivecam System would not be able to validate the video feed, basic information needed to address the system is being provided in this solution to help reduce troubleshooting time, while addressing areas of concern.

Lytx pushed out an "Over The Air" update to all of the SF500 ECUs that completed by July 12th 2024 changing the function of the LED located on the Lytx ECU. The location of the LED on the Lytx ECU can be seen in Figure 1. Make sure to have the ignition switch on when checking the LED, reference Figure 3 for location of Lytx ECU.



**Figure 1**

The LED has three states.

1. No LED color = no power to the ECU
2. Red = Power is connected
3. Green = If camera is connected and synced to the ECU (Green is Good)

In most cases customers being pointed to this solution will have the LED either in a "Red" or "Green" state as the problem is most likely related to an intermittent camera connection or wiring concern. As stated above, if the LED does not have a color, then the Lytx module is not powering up, this issue should be addressed first prior to proceeding to the next steps in the Service Solution. Wiring for the Lytx camera can be found in modules 6TS and 7B8 of the per S/N vehicle. Any damaged wires found in this service solution should be replaced.

**Inspection and areas of concern:**

Lytx SF500 Camera:

1. With the ignition switch off, ensure the Lytx SF 500 camera module is mounted correctly to the MPC3 mounting bracket. Camera module mates with plastic mounting bracket hooks, reference figure
2. Ensure Lytx SF500 camera module cable is correctly routed on the MPC3 mounting bracket. Both cables must have correct service loops and no additional/extra length of cable in this area. Additionally, cables must not be routed in front of the Bosch MPC3 camera. Refer to figure 2 for correct cable routing, red arrows showing visible cable routing while yellow arrows showing invisible cable routing (behind Bosch MPC unit). Failure to route the wires properly on the MPC3 mounting bracket can lead to chaffed or pinched wires.

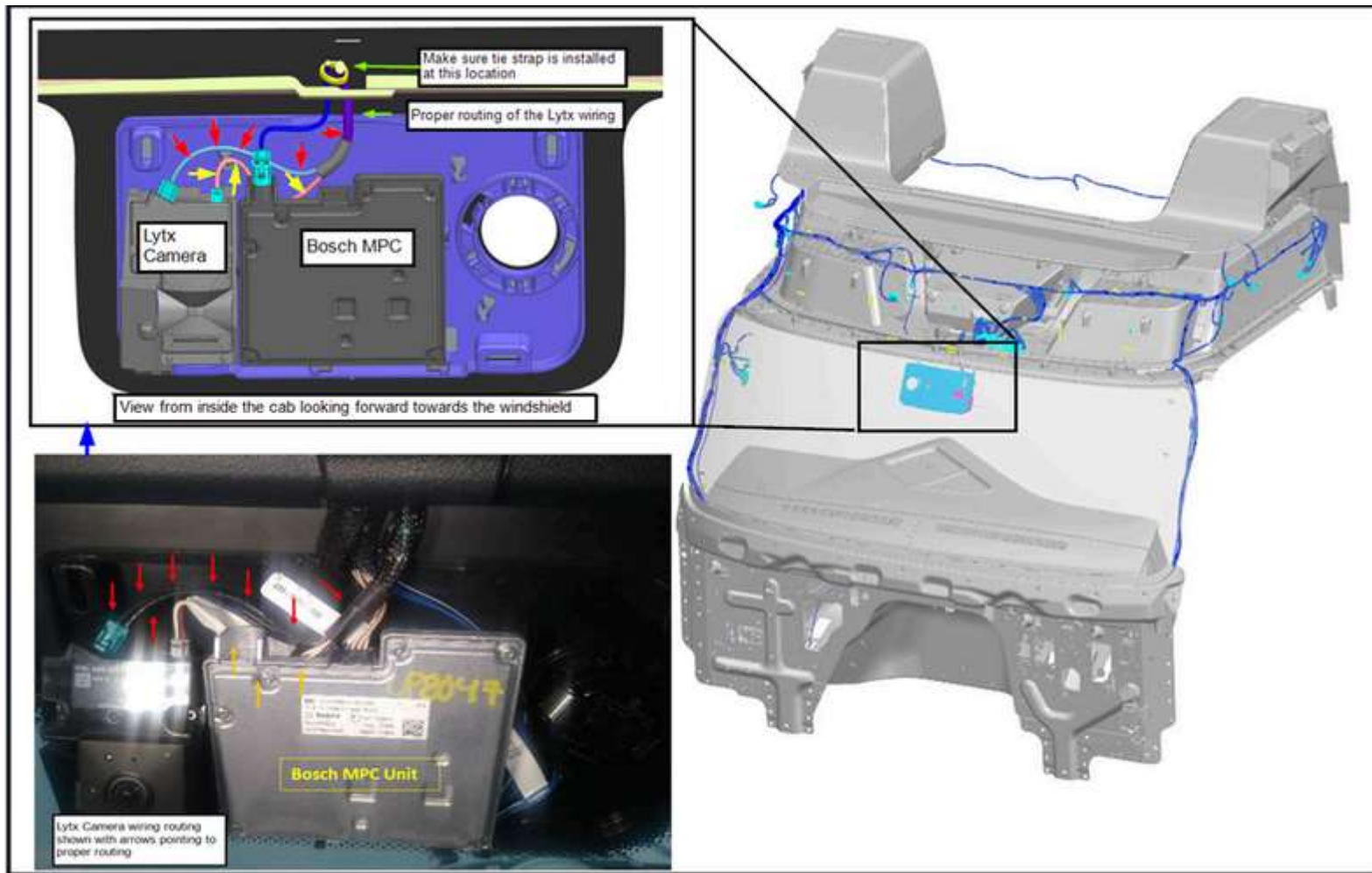

**Figure 2**

Lytx SF500 ECU mounting and wire routing:

1. Access the Lytx SF500 ECU by removing the panel on the dash. Cut all existing tie straps for both the Lytx ECU mounting along with the Lytx SF500 ECU and Camera module cable (pictured in purple) in figure 3. Remove all connections to the SF500 ECU. This will allow for the ECU to be remounted properly, while providing additional slack in the camera module cable allowing for the proper installation.

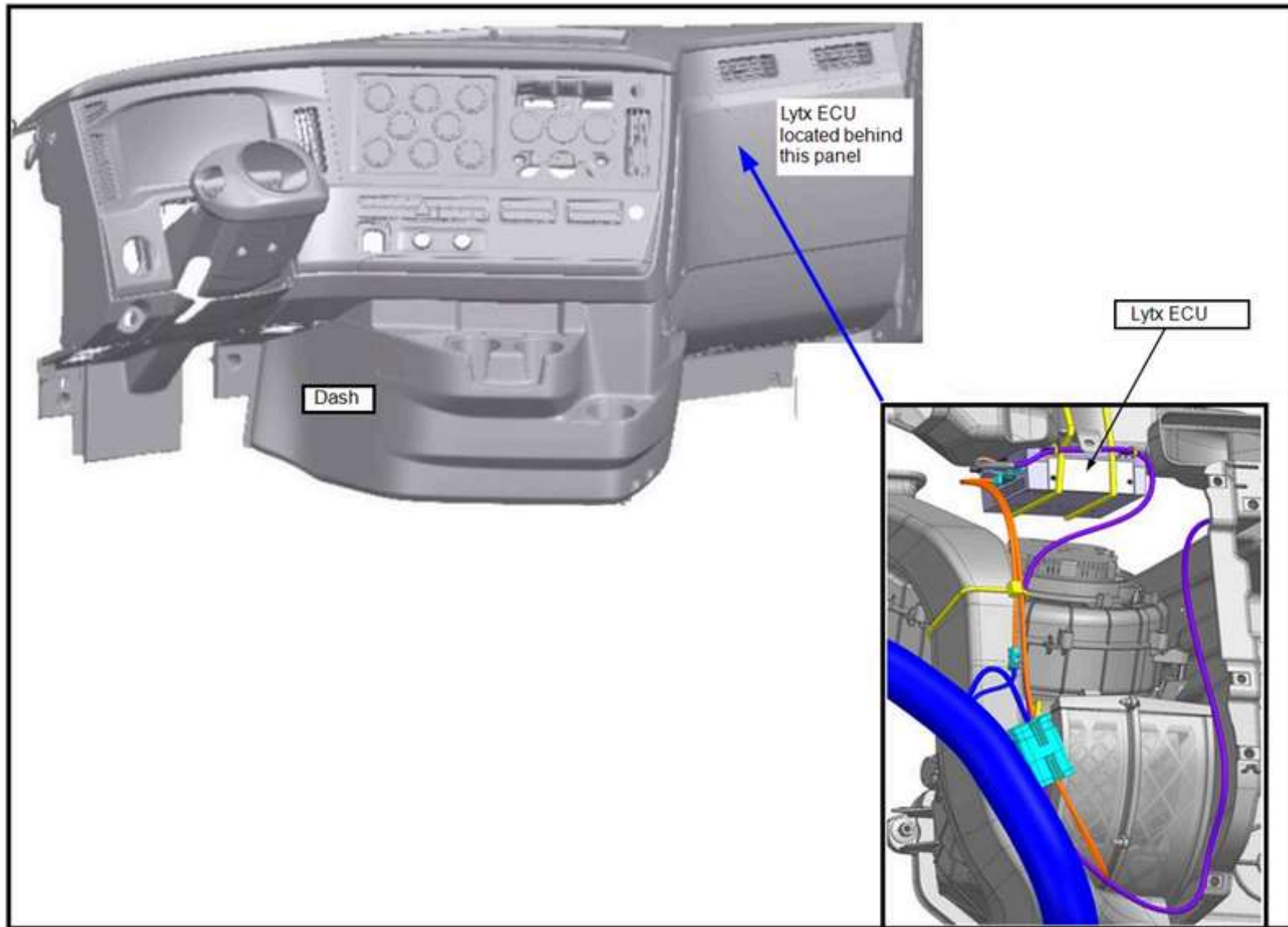

**Figure 3**

2. Ensure the Lytx SF500 ECU is correctly mounted and installed using 2 36" x 9mm tie straps reference Figure 4. Verify the 2 tie straps have an **approximate minimum gap** of 50mm or 2.0". The 2 tie straps must be fastened tightly, providing a secure mounting for the Lytx ECU. The ECU must not freely shift or rotate.

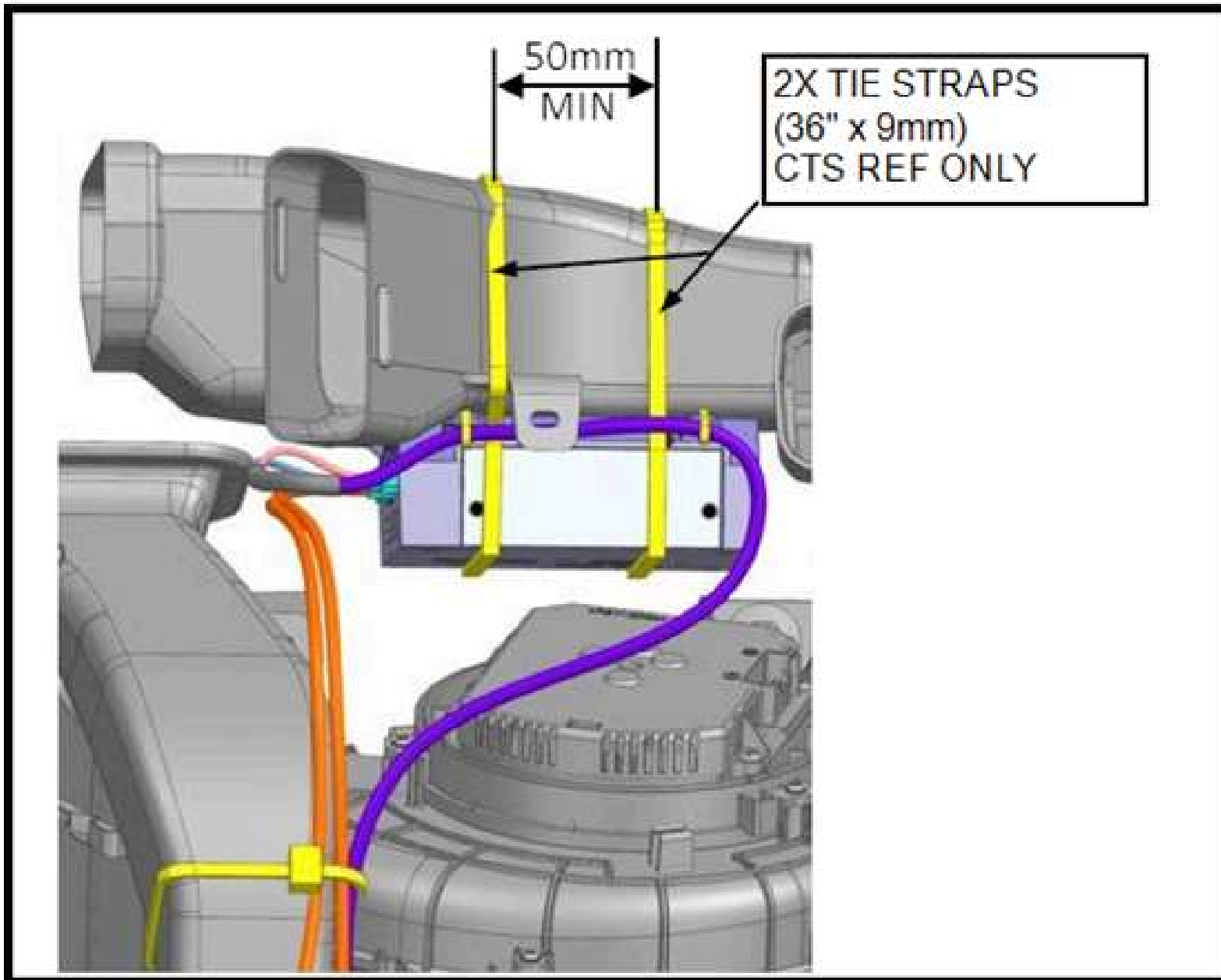
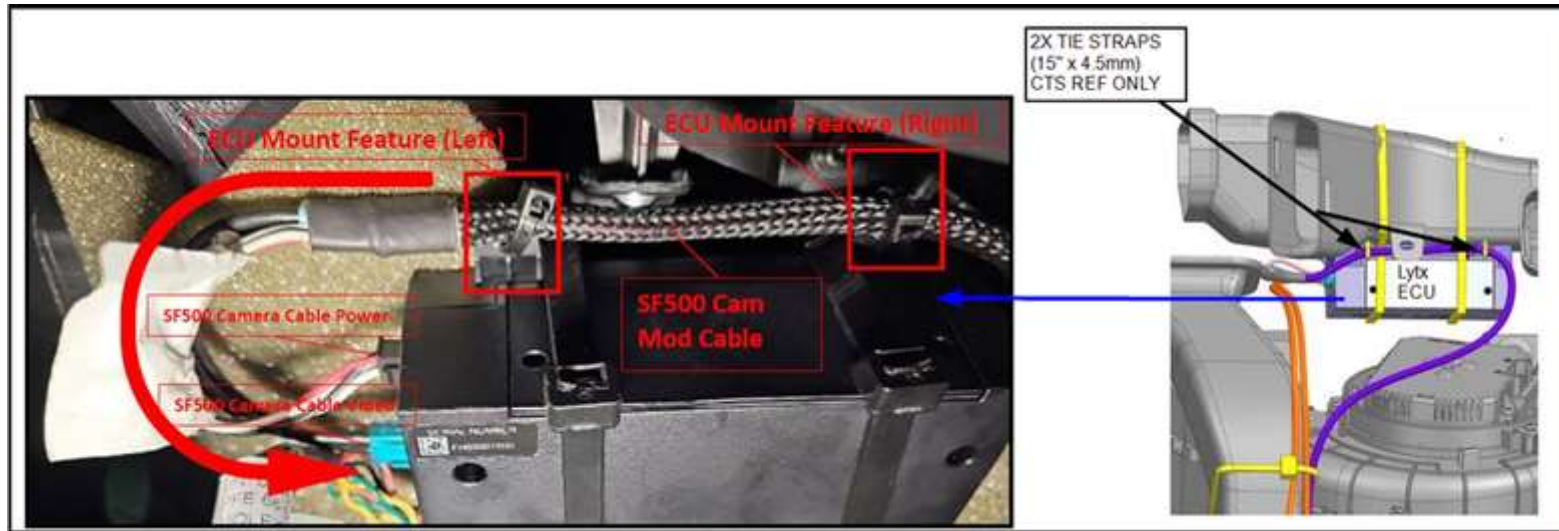

Figure 4

3. Fasten the SF500 Camera Module cable (pictured in purple) to the Lytx SF500 ECU using 2 tie straps 15" x 4.5mm threaded through the mounting ears of the ECU, refer Figure 5. Make sure the SF500 Camera Module cable (pictured in purple) is routed per figure 5. Make sure there is a service loop, providing strain relief, when attaching the cables back to the ECU. The left image in Figure 5 shows the service loop providing strain relief with the "U" shaped red arrow. Reconnect both power and video connectors to ECU.



**Figure 5**

4. Route the wires and cable going to the Lytx ECU per the green arrows in Figure 6. Install 2 15"x4.5mm tie straps to the HVAC ducting as pictured in Figure 6, with the upper tie strap going around the air duct and the low tie strap going around air duct/fan mounting bracket. Once the tie straps are secure, make sure to route the rest of the wiring per the green arrows.

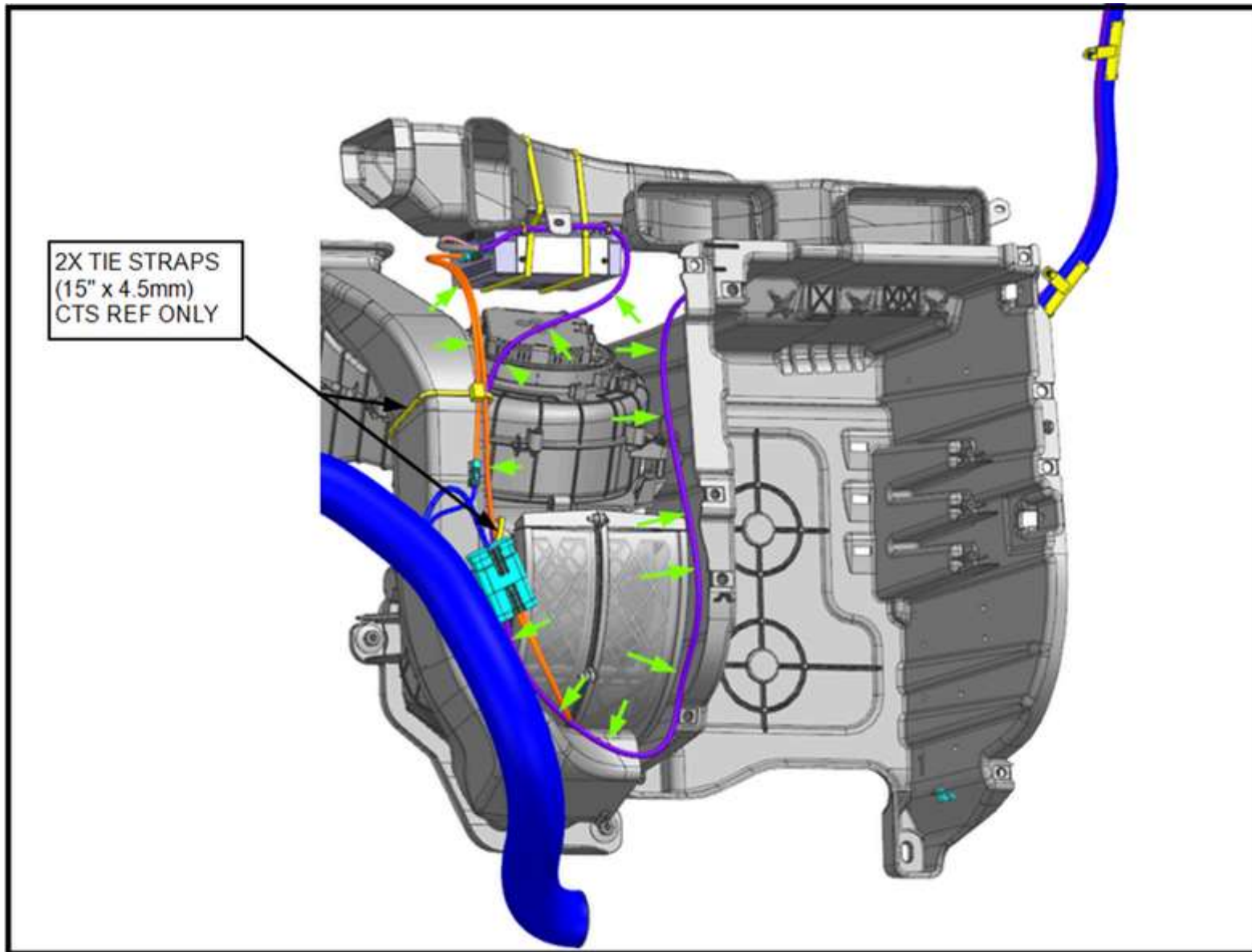

**Figure 6**

5. Once all of the wires and cables are routed per the instructions above, turn on the ignition switch and validate that the LED on the Lytx ECU module Figure 1 is green.
6. Reinstall all panels that had been removed to correctly install the Lytx cables and wires.

Labels :

**Electrical**

**New Cascadia**

Add tags

 0 Kudos