



SIB 28 02 24

2024-07-03

SERVICE ACTION: DOUBLE CLUTCH TRANSMISSION REWORK AT TRANSFER CASE

This Service Information Bulletin (Revision 2) replaces SI B28 02 24 **dated May 2024**.

What's New (Specific text highlighted):

- Procedure updated
- Parts list updated

Please perform the procedure outlined in this Service Information on all affected vehicles before customer delivery. In the event the customer has already taken delivery of the vehicle, please perform the procedure the next time the vehicle is in the shop if the campaigns have a status of remedy available. Otherwise, please release the vehicle.

THIS REPAIR IS MOBILE FRIENDLY

MODEL

U11 (X1 Sports Activity Vehicle)	U10 (X2 Sports Activity Coupe)
----------------------------------	--------------------------------

AFFECTED VEHICLES

- Vehicles which require this campaign to be completed will show it as “Open” when checked either in AIR, AWP, Campaign Summary, or Warranty Vehicle Inquiry.
- Please make sure you check your dealer inventory as soon as possible. You can see a list of affected vehicles in Inventory Campaign Details (ICD) under ROSS.

SITUATION

Micro-movements combined with frictional corrosion can increase wear on the longitudinal splined connection between the double clutch transmission (DCT) and the transfer box.

CORRECTION

Add spacers at the connection between the DCT and transfer box to decrease micro-movements.

PROCEDURE

Follow Repair instruction **31 60 004 Removing and installing/replacing right output shaft** to remove the right output shaft. The starter motor needs to be removed/moved aside to access one of the bolts for the spacer.

If this repair instruction is not available in AIR/ISTA: Use Repair Instruction **27 10 110 Replace radial shaft sealing ring for connecting shaft right** as an alternative.

Contrary to these repair instructions 27 10 110, it is not necessary to replace the shaft sealing ring with part number 27 10 8627023.

Remove the stabilizer link (1).

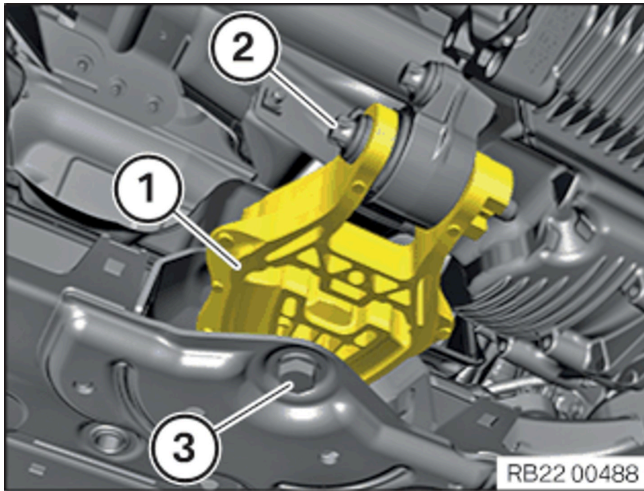

Reinstallation: Replace bolts 2 and 3

Tighten to 100 Nm and torque angle 90°

Remove the two bolts (1) on the transfer case.

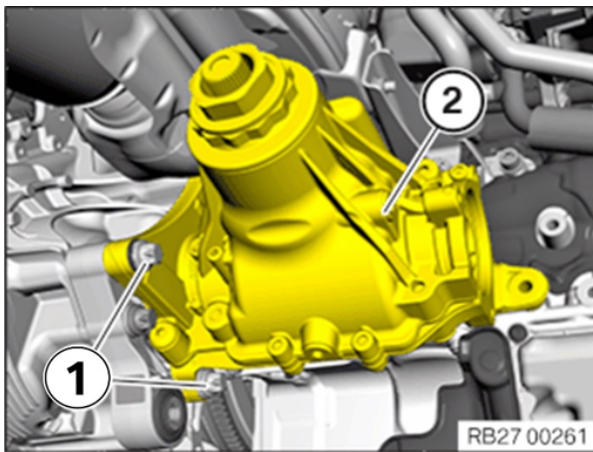

Reinstallation: Replace both bolts

Tighten to 100 Nm and torque angle 90°

Install washers between the link and transfer case. It may be necessary to slightly push the transfer case to the side to install the washers.

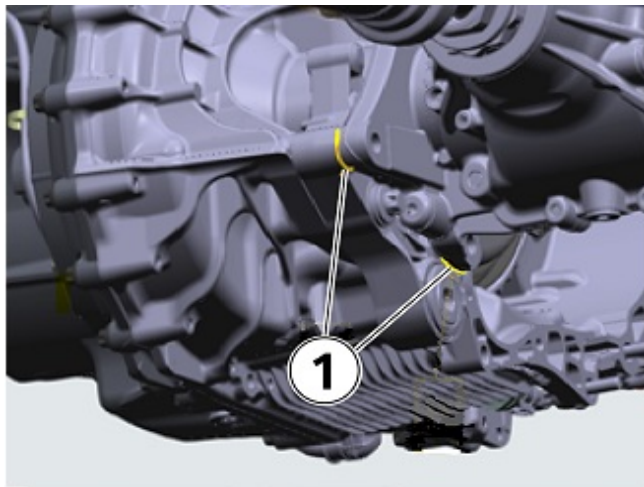

Reinstall the right axle.

PARTS INFORMATION

To determine the part number(s) that applies to the specific vehicle being repaired, enter the VIN/chassis number into either ETK or AIR, this will consider the specific equipment and/or options that are fitted to the vehicle.

Part Number	Description	Quantity
07 11 9 909 844	Hex Bolt (M12x1.5x90)	1
07 14 9 894 132	Multi-purpose bolt ASA (M12x90x1.5)	2
27 10 0 807 707	Retaining ring	1

Copyright ©2024 BMW of North America, Inc.

37 14 6 869 771	Thread-tapping hexagon bolt	1
31 20 6 866 022	Shouldered bolt with compression spring	1
22 11 8 876 816	Adapter washer kit	2
33 30 6 760 587	Flanged hexagon nut	1
31 10 6 876 027	ASA bolt	1
07 11 9 909 527	Hexagon bolt	1
07 11 9 906 927	Hexagon bolt	1

Additionally, other materials and small parts that are not specified above, such as fluids, lubricants, one-time use screws, nuts, and seals, which must be replaced or installed (according to the ISTA repair instructions/ETK/AIR), are to be selected from the Electronic Parts Catalog, and/or other approved BMW resources according to the respective vehicle type. Invoiced these items separately under the Repair Code listed in this bulletin.

CLAIM INFORMATION

Reimbursement for this Service Action will be via normal claim entry utilizing the applicable work package information below and the part numbers listed above.

Repair Code:	0028240100	U10 U11 Reworking DKG connection - transfer box
---------------------	-------------------	--

Below are the special flat rate labor operation code choices for this action.

Completion before the first vehicle delivery to a customer or the vehicle is already in the workshop.

Work Pkg	Labor Operation	Description (Plusposition work)	Labor Allowance
# 1	00 75 871	Reworking the interface between the double clutch transmission and the transfer box	As applicable

Or:

The vehicle arrives at your center and this Service Action shows open (No other Main work will be performed or claimed during this workshop visit).

Work Pkg	Labor Operation	Description (Main work)	Labor Allowance
# 2	00 75 284	Reworking the interface between the double clutch transmission and the transfer box	As applicable

Only one of the flat rate labor operation codes listed above can be used for claim submission and reimbursement. Also, only one Main work flat rate labor operation code can be claimed per workshop visit.

Claim Repair Comments

Only reference the SIB number and the work package (Pkg) number performed in the RO technician notes and the claim comments (For example: B28 02 24 WP 1), unless otherwise required by State law.

And:

Sublet – Bulk Supply Materials (RO and Claim Comments Required)

Sublet Code 4	Reimbursement for the repair-related bulk supply materials (Do not use the BMW part numbers for claim submission)	Up to \$25.00
----------------------	---	---------------

Sublet reimbursement calculation for claiming the applicable repair-related bulk supply materials (BMW part
Copyright ©2024 BMW of North America, Inc.

Enter this material cost in sublet and itemize the amount on the repair order and in claim comment section.

Alternative Mobility Solution (AMS) for Vehicle Owners (RO and Claim Comments Required)

This Service Action repair qualifies for Alternative Mobility Solution (AMS) expense reimbursement, claim this item under the Defect Code noted above as follows:

Sublet Code 2 - Itemize the AMS sublet amount on the repair order and in the claim comment section.

Please refer to [SI B01 29 16](#) for additional information.

BMW Group's AIR Application Resource for Flat Rate Labor Operation Codes

To obtain the corresponding flat rate unit (FRU) allowance information from the BMW Group AIR application resource, start by entering the Chassis Number (the last seven (7) characters of the VIN, select the applicable Model if two or more vehicle choices show), or enter the full VIN (17 characters), click on the "Search" button. Next, click on the "Flat Rate Units" button and enter the flat rate labor operation code in the field to the right, click "Search" to display the Flat Rate Unit Group detail choices.

FEEDBACK REGARDING THIS BULLETIN

Technical Feedback	To submit feedback for the technical topic of this bulletin: Submit your feedback in the rating box at the top of this bulletin
Warranty Feedback	To submit feedback for the CLAIMS section of this bulletin: Submit an IDS ticket to the Warranty Department, or use the chat available in the Warranty Documentation Portal
Parts Feedback	To submit feedback for the PARTS section of this bulletin: Submit an IDS ticket to the Parts Department

