

REFERENCE:	TSB: 03-007-24 REV. A GROUP: 03 - Differential and Driveline	Date:	July 19, 2024	REVISION:	03-007-24
VEHICLES AFFECTED:	2024 (JL) Jeep Wrangler This bulletin applies to vehicles built on or before **June 10, 2024 (MDH 0610XX)** equipped with the Dana M220 Wide Full Floating RR Axle (Sales Code DRN).			MARKET APPLICABILITY:	
				<input type="checkbox"/> NA	<input type="checkbox"/> MEA
				<input type="checkbox"/> SA	<input checked="" type="checkbox"/> IAP
				<input type="checkbox"/> EE	<input type="checkbox"/> CH
CUSTOMER SYMPTOM:	Customers may experience the following: <ul style="list-style-type: none"> Intermittent grinding, screeching, ratcheting noise coming from the right hand side of vehicle on the rear axle. 				
CAUSE:	Lack of lubrication				

This bulletin supersedes Technical Service Bulletin (TSB) 03-007-24, date of issue July 16, 2024, which should be removed from your files. All revisions are highlighted with ****asterisks**** and include an updated build date.

This Technical Service Bulletin (TSB) has also been released as a Rapid Service Update (RSU) 24-104, date of issue July 16, 2024. All applicable RSU VINs have been loaded. To verify this RSU service action is applicable to the vehicle, use VIP or perform a VIN search in DealerCONNECT/Service Library. All repairs are reimbursable within the provisions of warranty.

REPAIR SUMMARY:

This bulletin involves cleaning and lubricating the axle shaft and hub splines.

CLAIMS DATA:

Labor Operation No:	Labor Description	Skill Category	Labor Time
03-20-01-99	Shaft, Right Rear Axle, Clean and Lubricate (2 - Skilled)	3 - Differential and Drive-line	0.6 Hrs.
Failure Code	ZZ	Service Action	

SPARE PARTS:

Qty	Part No.	Description	Notes
1 (AR)	05083150AA	Mopar® Wheel Bearing Grease	1/100 of the 14.5 ounce cartridge
4	68003275AA	Hex Flange Lock Nut	Tube flange to hub unit nut
1 (AR)	68651258AA	O-Ring	Wheel Hub Bearing

DIAGNOSIS:

If a customer's VIN is listed in VIP or your RSU VIN list, perform the repair. If any vehicle not on the VIN list exhibits any of the symptom listed above in the customer symptom section, perform the Repair Procedure.

REPAIR PROCEDURE:

1. Remove the brake caliper and rotor. Refer to the detailed service procedures available in DealerCONNECT/Service Library under: Service Info> Refer to 05 - Brakes, Base/Hydraulic/Mechanical/ Rotor, Brake/Removal.
2. Remove the wheel speed sensor from the tube assembly. Refer to the detailed service procedures available in DealerCONNECT/Service Library under: Service Info> Refer to 05 - Brakes, ABS/Electrical/ Sensor, Wheel Speed, Rear/Removal.
3. Disconnect the parking brake cable from the parking brake actuator at the backing plate.
4. Remove and **DISCARD** the four nuts [Fig. 1](#) from the hub assembly.

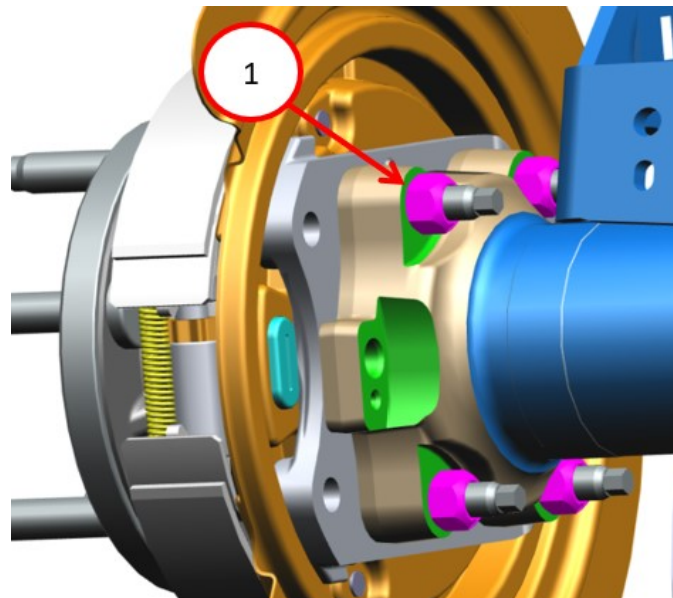

Fig. 1
Hub Nuts

1 - Axle Housing

5. Use a pry bar to pry between the upper control arm bracket and the hub stud end to extract the hub from the tube assembly.
6. Remove the axle shaft, hub and bearing assembly with backing plate from the axle housing.
NOTE: Inspect the O-ring for damage and replace if needed.
7. Remove the axle shaft from the hub.

- Using brake cleaner and a wire brush, clean both the interface of the shaft splines and hub splines to remove any of the “fretting/corrosion” seen on those splines [Fig. 2](#).

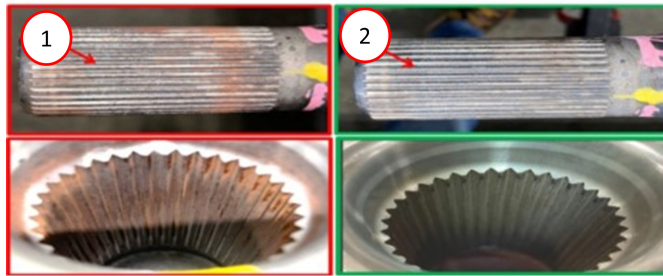

Fig. 2
Axle Shaft Splines/Hub Splines

1 - Axle Shaft/Hub Splines Prior To Cleaning
2 - Axle Shaft/Hub Splines After Cleaning

NOTE: After cleaning the interface use forced air to remove any remaining debris on interface.

- Use wheel bearing grease to lubricate both the hub splines and the axle shaft splines. Ensure to coat the whole surface of the spline interface on the shaft and hub [Fig. 3](#).



Fig. 3
Lubricated Axle Shaft/Hub splines

- Install the axle shaft into the hub by hand until it bottoms out.

NOTE: Air may purge through the shaft splines at any time throughout the shaft installation process.

11. Lubricate the tube flange inside diameter with 75-85W sump lube as this aids in O-ring guidance [Fig. 4](#).

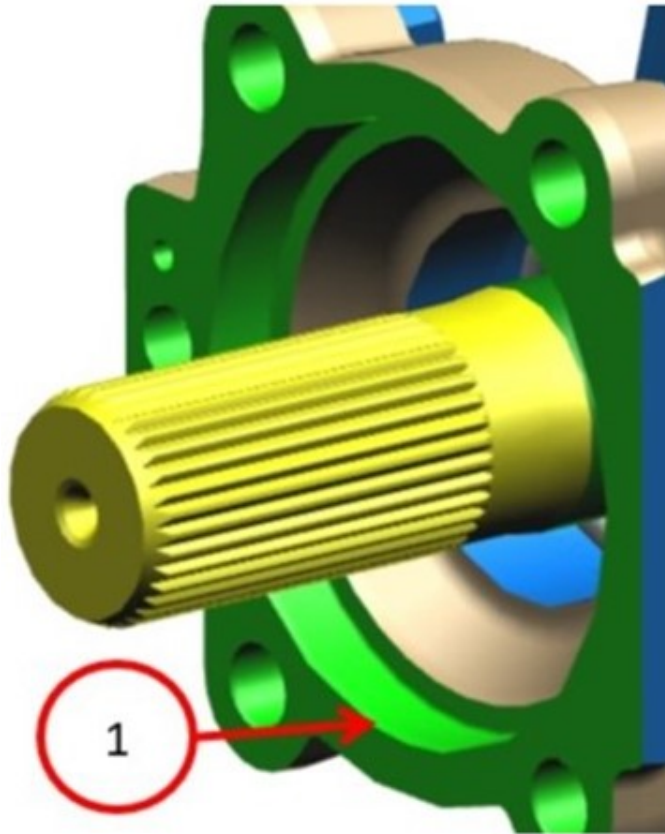

Fig. 4
Tube Flange Diameter To Lubricate

1 - Area To Apply Lubricant To The Tube Flange Surface

12. Install the axle shaft, hub and bearing assembly with backing plate onto the shaft then into the tube aligning the four hub studs ensuring the wheel speed sensor hole in the backing plate aligns with the wheel speed sensor hole/pad on the tube assembly.
13. Install four **NEW** hub nuts [Fig. 1](#) on the hub assembly.
14. Connect the parking brake cable from the parking brake actuator at the backing plate.
15. Install the wheel speed sensor from the hub. Refer to the detailed service procedures available in DealerCONNECT/Service Library under: Service Info> Refer to 05 - Brakes, ABS/Electrical/Sensor, Wheel Speed, Rear/Installation.
16. Install the brake caliper and rotor. Refer to the detailed service procedures available in DealerCONNECT/Service Library under: Service Info> Refer to 05 - Brakes, Base/Hydraulic/Mechanical/Rotor, Brake/Installation.

POLICY:

Reimbursable within the provisions of the warranty.

This bulletin is supplied as technical information only and is not an authorization for repair. No part of this publication may be reproduced, stored in a retrieval system, or transmitted, in any form or by any means, electronic, mechanical, photocopying, or otherwise, without written permission of FCA US LLC.