



Service Bulletin

Bulletin No.: 21-NA-138

Date: July, 2024

TECHNICAL

Subject: Squeak, Grind or Clunking Noise from Rear Leaf Springs
Attention: This bulletin applies to Heavy Duty vehicles only. Refer to Bulletin 19-NA-129 for Light Duty vehicles.

Brand:	Model:	Model Year:		VIN:		Engine:	Transmission:
		from	to	from	to		
Chevrolet	Silverado HD	2015	2018	—	—	—	—
	Silverado 2500HD/ 3500HD	2019	2025				
GMC	Sierra HD	2015	2018				
	Sierra 2500HD/ 3500HD	2019	2025				

Involved Region or Country	North America, Middle East, Israel, Australia and New Zealand
Condition	Some customers may comment that a squeak, grind or clunking noise can be heard from the rear leaf springs.
Cause	This condition may be caused by the spring insert interacting with the leaf spring. Note: Some noise is characteristic with leaf spring suspensions when going over bumps.
Correction	<div style="text-align: center;">  </div> <p style="text-align: right;">5341853</p> <p>A new insert with a graining pattern will help reduce this noise. Replace the rear spring inserts utilizing a plastic trim tool or plastic wedge in between the leaf springs. Important: After new spring tip inserts are installed per this bulletin, new inserts have a break-in period of up to 1610 km (1000 miles), where some noise can be expected.</p>

Important: Service agents must comply with all International, Federal, State, Provincial, and/or Local laws applicable to the activities it performs under this bulletin, including but not limited to handling, deploying, preparing, classifying, packaging, marking, labeling, and shipping dangerous goods. In the event of a conflict between the procedures set forth in this bulletin and the laws that apply to your dealership, you must follow those applicable laws.

Service Procedure

1. Raise and secure the vehicle.
2. utilizing a jack, support the rear axle.

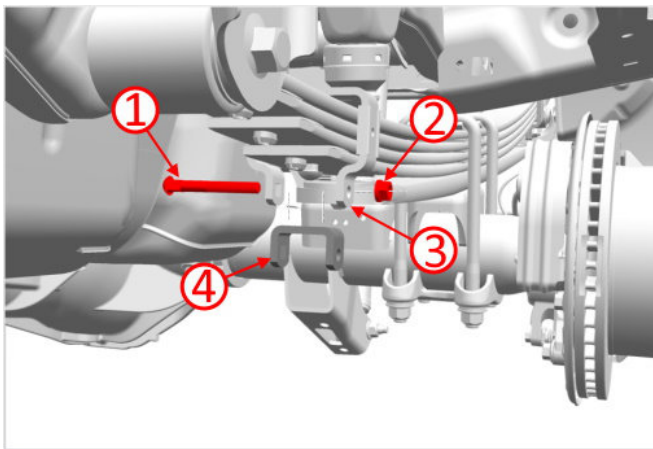

5862786

3. Remove the bolt (1) the secures the clip (4) to the spring alignment bracket (3) for both spring assemblies.
4. Slowly lower the jack to relieve the spring of tension.

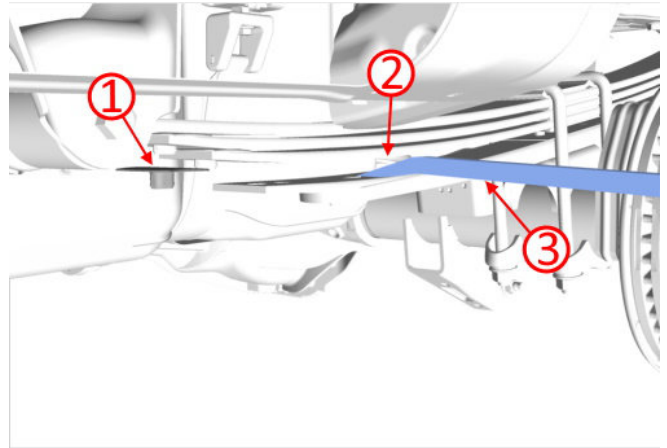

5862787

Note: DO NOT chip the painted coating on the springs when performing the repair. place a rag (2) in the area where contact with the spring may occur.

5. Utilizing a plastic trim tool, plastic wedge (3) or equivalent, separate the rear springs.



5863011

6. Using a rag and degreaser, clean any dirt or grease from between the leaf springs at the insert location.
7. Replace all the inserts for the left and right-side springs.
8. Using care, raise the jack.
9. Install the clip and bolt back onto the alignment bracket.

Tighten

Torque the fastener to D22.3 +/- 2.0 NM.

10. Lower and remove the jack.
11. Lower the vehicle.

Parts Information

Causal Part	Description	Part Number	Qty
X	INSERT, RR SPR LEAF (KIT)	87838974 (SRW)	1
X		87838975 (DRW)	1

Warranty Information

For vehicles repaired under the Bumper-to-Bumper coverage (Canada Base Warranty coverage), use the following labor operation. Reference the Applicable Warranties section of Investigate Vehicle History (IVH) for coverage information.

Labor Operation	Description	Labor Time
8080628*	Rear Leaf Spring Insert Replacement	1.0 hr
*This is a unique Labor Operation for bulletin use only.		

Version	
	5
Modified	<p>Released August 05, 2021</p> <p>Revised on August 26, 2021 - Add Attention statement.</p> <p>Revised October 20, 2022 - Added 2022 to Model Year and Update Part Numbers in Parts Information section.</p> <p>Revised January 24, 2023 - Added SRW and DRW to Parts Information section.</p> <p>Revised July 08, 2024 - Added 2024 to 2025 Model Years.</p>

