



TECHNICAL SERVICE BULLETIN

Classification: DA23-004A	Reference: NTB23-076A	Date: May 14, 2024
------------------------------	--------------------------	-----------------------

INTELLIGENT AROUND VIEW MONITOR CAMERA CALIBRATION

This bulletin has been amended. See **AMENDMENT HISTORY** on the last page.
Please discard previous versions of this bulletin.

APPLIED VEHICLES: 2023-2024 ARIYA (FE0)
APPLIED SYSTEMS: Intelligent Around View Monitor with ProPILOT Park

SERVICE INFORMATION

If any Around View Monitor (AVM) camera (front, sides, or rear) and/or the AVM Control Module is replaced, camera calibration is required.

The **SERVICE PROCEDURE** in this bulletin can be used in conjunction with the ESM and CONSULT 4 procedures for additional clarification when performing AVM camera calibration.

- Refer to the ESM: **DRIVER INFORMATION & MULTIMEDIA > AUDIO, VISUAL & NAVIGATION SYSTEM > INTELLIGENT AROUND VIEW MONITOR > BASIC INSPECTION > CALIBRATING CAMERA IMAGE (INTELLIGENT AROUND VIEW MONITOR) > WITH ProPILOT PARK**

Bulletins are intended for use by qualified technicians, not 'do-it-yourselfers'. Qualified technicians are properly trained individuals who have the equipment, tools, safety instruction, and know-how to do a job properly and safely. **NOTE:** If you believe that a described condition may apply to a particular vehicle, DO NOT assume that it does. See your Nissan dealer to determine if this applies to your vehicle.

REQUIRED TOOLS

New or replacement Essential Tools are available from Tech Mate online: www.techmatetools.com, or by phone: 1-833-397-3493.

- Laser level (NI-53373)



Figure 1

- Carpenter's folding ruler (NI-53371)



Figure 2

- Calibration Targets (NI-53378)



Figure 3

The following required tools can be obtained from any local retailer.

- Carpenter's square (minimum 12 in. long leg)



Figure 4

- Painter's tape [minimum width 1 7/8 in. (48 mm)]



Figure 5

- Permanent marker



Figure 6

- Chalk line tool



Figure 7

- Tape measure (must have metric markings)



Figure 8

SERVICE PROCEDURE

IMPORTANT:

- A large area, free from obstructions, is needed to calibrate each camera.
- HINT:** The shop floor area requirements are shown in Figure 9 (only one camera will be calibrated at a time so the vehicle can be repositioned for each camera as needed).
- A strong Wi-Fi or mobile hotspot is required.
 - The floor should be as level as possible (drains are not allowed).
 - The floor needs to be clean and dry, otherwise the tape will not stick and markings will not be clear.
 - The hood must remain closed.
 - The 12V battery must be in good condition.
 - The main battery must have a high state of charge, over 75%, due to length of time required.
 - All measurements must be done in millimeters (mm).
 - Fans should be avoided for target stability and laser level.

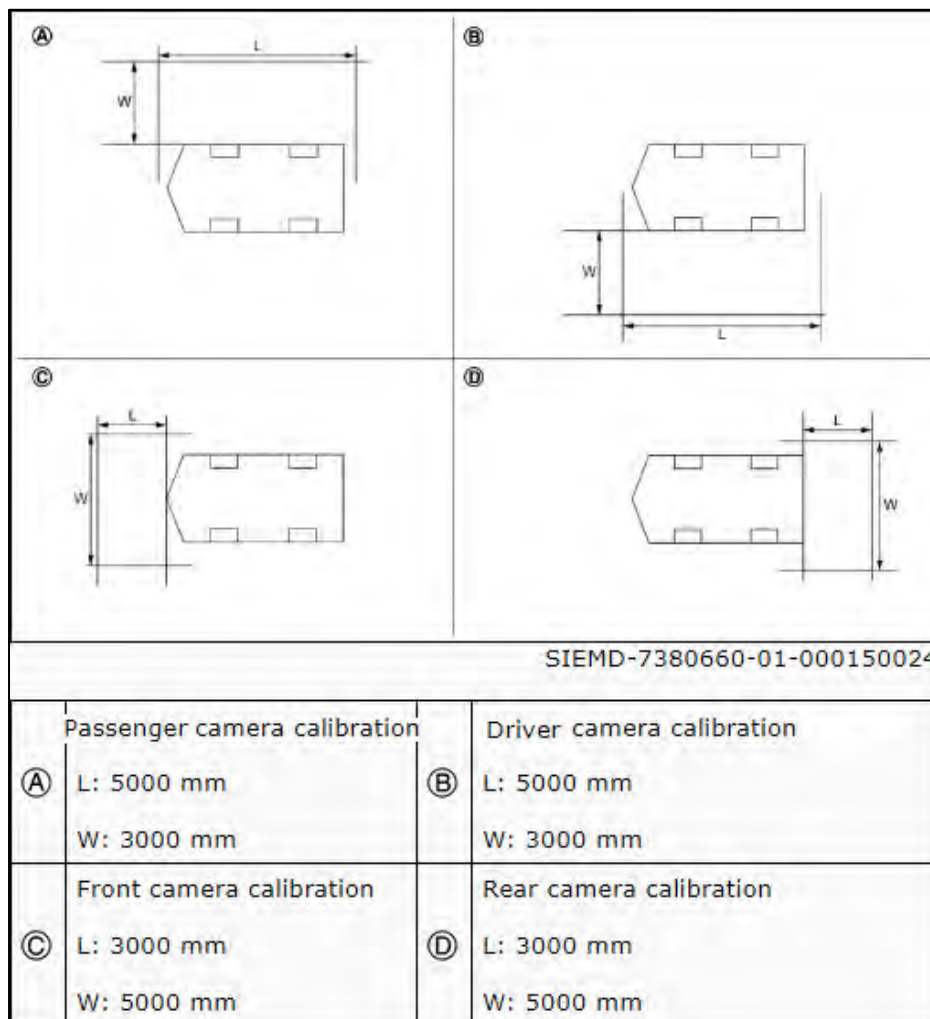

Figure 9

IMPORTANT: Before starting, make sure ASIST on the CONSULT PC has been synchronized (updated) to the current date.

1. Put the vehicle in READY mode.
2. Confirm that the CONSULT PC is connected to Wi-Fi.
3. Connect the Vehicle Interface (VI) to the vehicle.
4. Start CONSULT 4 on the CONSULT PC.
5. If prompted, select **USA/CANADA Dealers** from the drop-down menu, and then select **OK**.

6. Login using your NNAnet credentials.

IMPORTANT: If not prompted to enter your username and password, the CONSULT PC may not be connected to Wi-Fi. Close CONSULT 4, confirm the CONSULT PC is connected to Wi-Fi, and then reopen CONSULT 4.

7. Wait for the VI to be recognized.
8. Clear any DTC(s).
 - If any DTC(s) remain after attempting to clear the DTC(s), turn the ignition OFF, remove the key, close the doors, and walk away from the vehicle for a minimum of 10 minutes.
9. Select **AVM**.

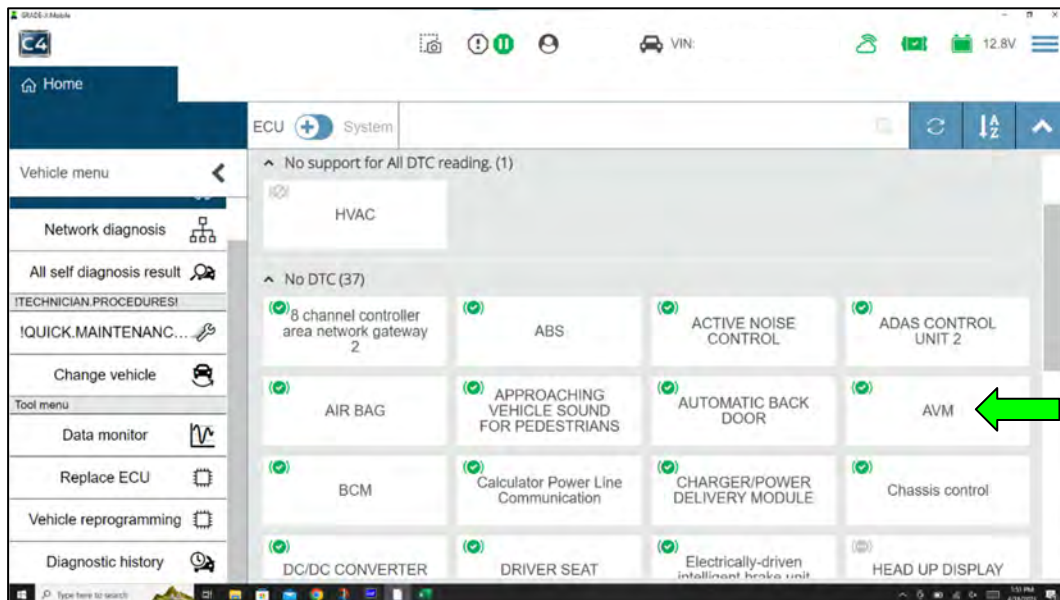

Figure 10

10. Select **Work supports**.

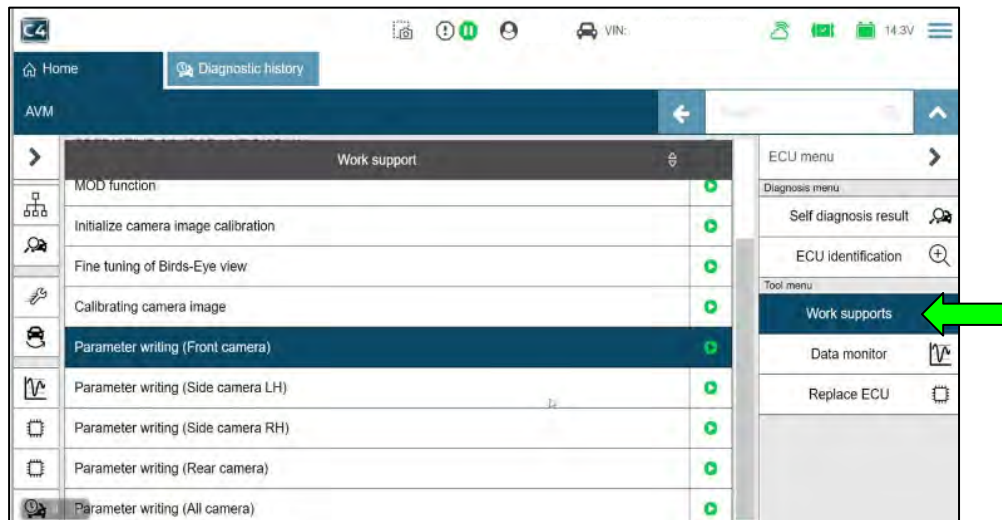

Figure 11

11. If one or more cameras were replaced, select the parameter writing for the camera that was replaced, and then select the green Play icon next to the selected camera.

IMPORTANT: If the AVM was replaced, and a camera was not, skip to step 12 on page 8.

HINT:

- It may take up to 5 minutes for the screen in Figure 13 on page 8 to display once the green Play icon is selected.
- Parameter writing needs to be performed for each of the camera(s) that were replaced.

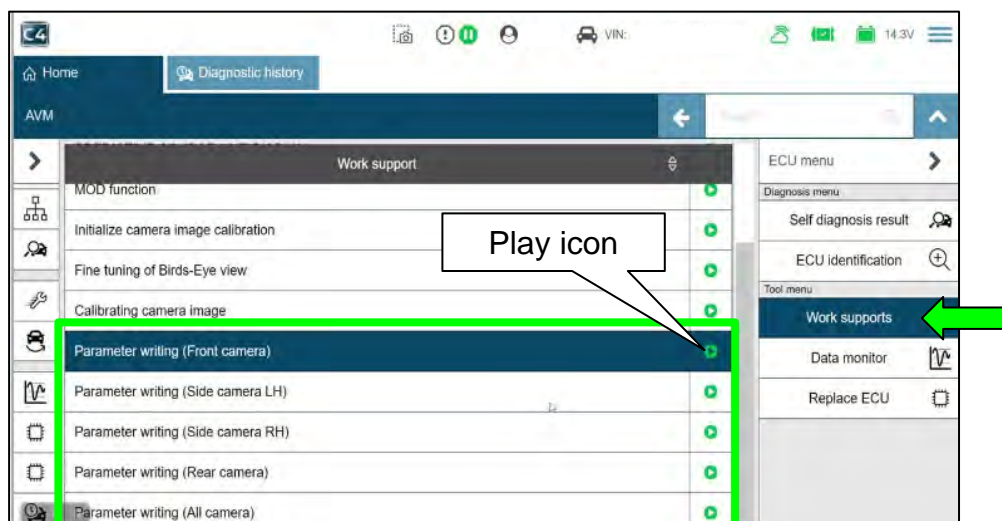

Figure 12

- If the **Parameter writing** is successful (Figure 13), select **END** and then continue to step 12.
- If the **Parameter writing** was not successful (Figure 14):

HINT: The CONSULT PC can remain connected to the vehicle during this process.

- Turn the vehicle OFF.
- Close and lock all the doors.
- Move the keys away from the vehicle a minimum of 30 ft.
- Wait 10 minutes.
- Put the vehicle in READY mode.
- Select **Retry**.
- Once the **Parameter writing** is successful, continue to step 12.

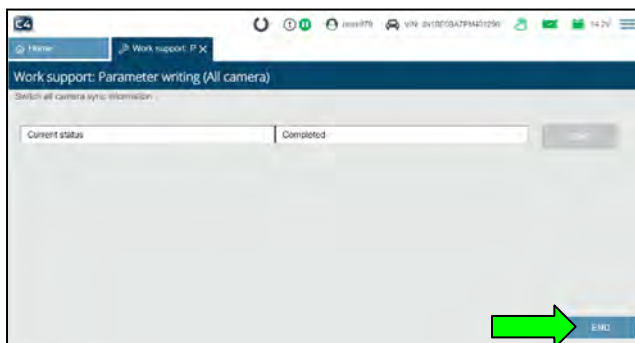

Figure 13

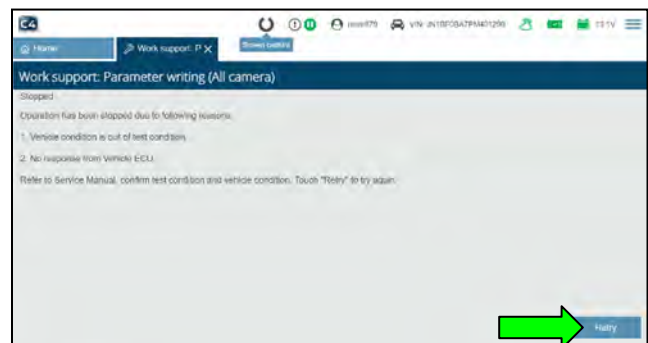

Figure 14

12. Select **Parameter writing (All camera)**, and then select the green Play icon.

HINT: It may take up to 5 minutes for the screen in Figure 16 on page 9 to display once the green Play icon is selected.

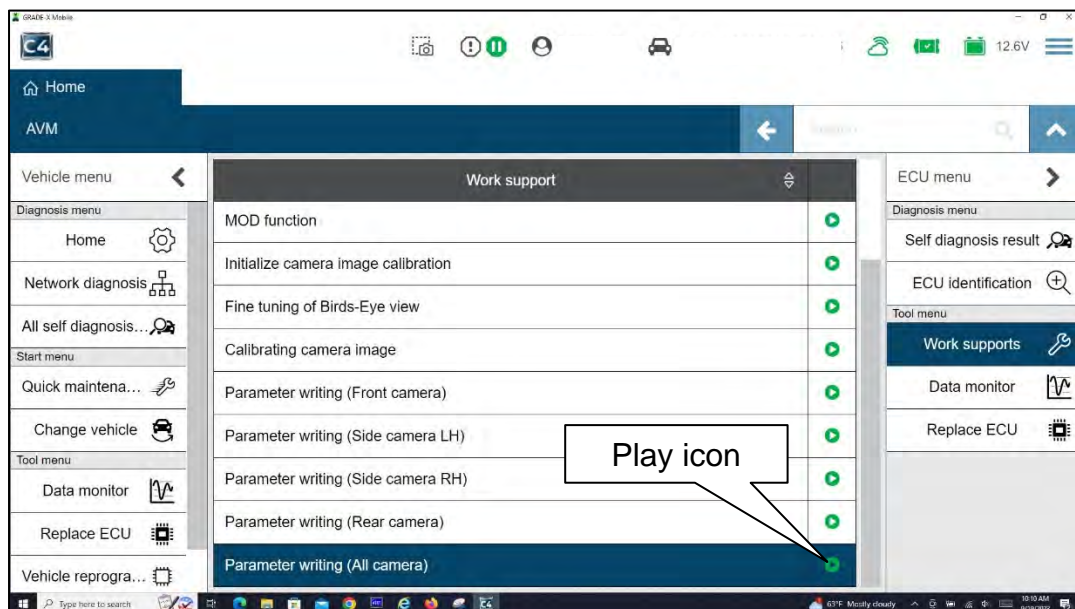

Figure 15

- If the **Parameter writing** is successful (Figure 16), select **END** and then continue to step 13.
- If the **Parameter writing** was not successful (Figure 17):

HINT: The CONSULT PC can remain connected to the vehicle during this process.

- Turn the vehicle OFF.
- Close and lock all the doors.
- Move the keys away from the vehicle a minimum of 30 ft.
- Wait 10 minutes.
- Put the vehicle in READY mode.
- Select **Retry**.
- Once the **Parameter writing** is successful, continue to step 13.

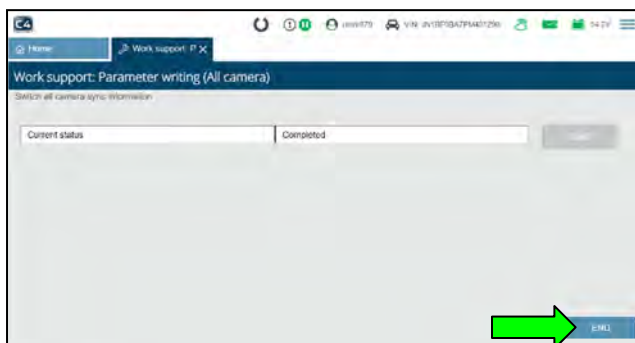

Figure 16

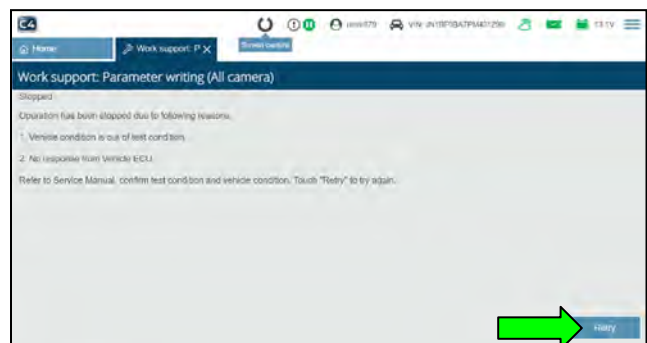

Figure 17

13. Check for any camera(s) that requires calibration.

HINT:

- Any camera(s) that have a red boxed X will require calibration, proceed to step 14 on page 10 to start marking the center point for each wheel and tire assembly.

HINT: All four (4) cameras in Figure 18 require calibration.

- If there are no red boxed X's on the screen, the image on the screen appears OK, and any DTCs present are PAST, camera calibration is not required, skip to step 96 on page 67.

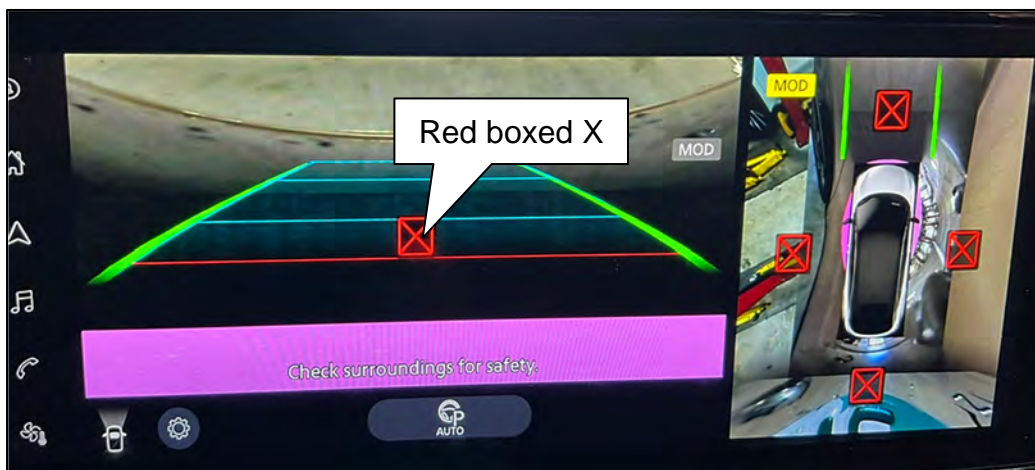

Figure 18

Marking the Center Point of the Wheel and Tire Assemblies

14. Place the laser level approximately 800 mm (31.5 in.) from the wheel and tire assembly.



Figure 19

15. Align the vertical laser line to the wheel axle centerline (wheel center cap).



Figure 20

16. Mark the wheel arch and the floor near the tire.

HINT: The use of painter's tape helps capture the markings on the vehicle and floor.

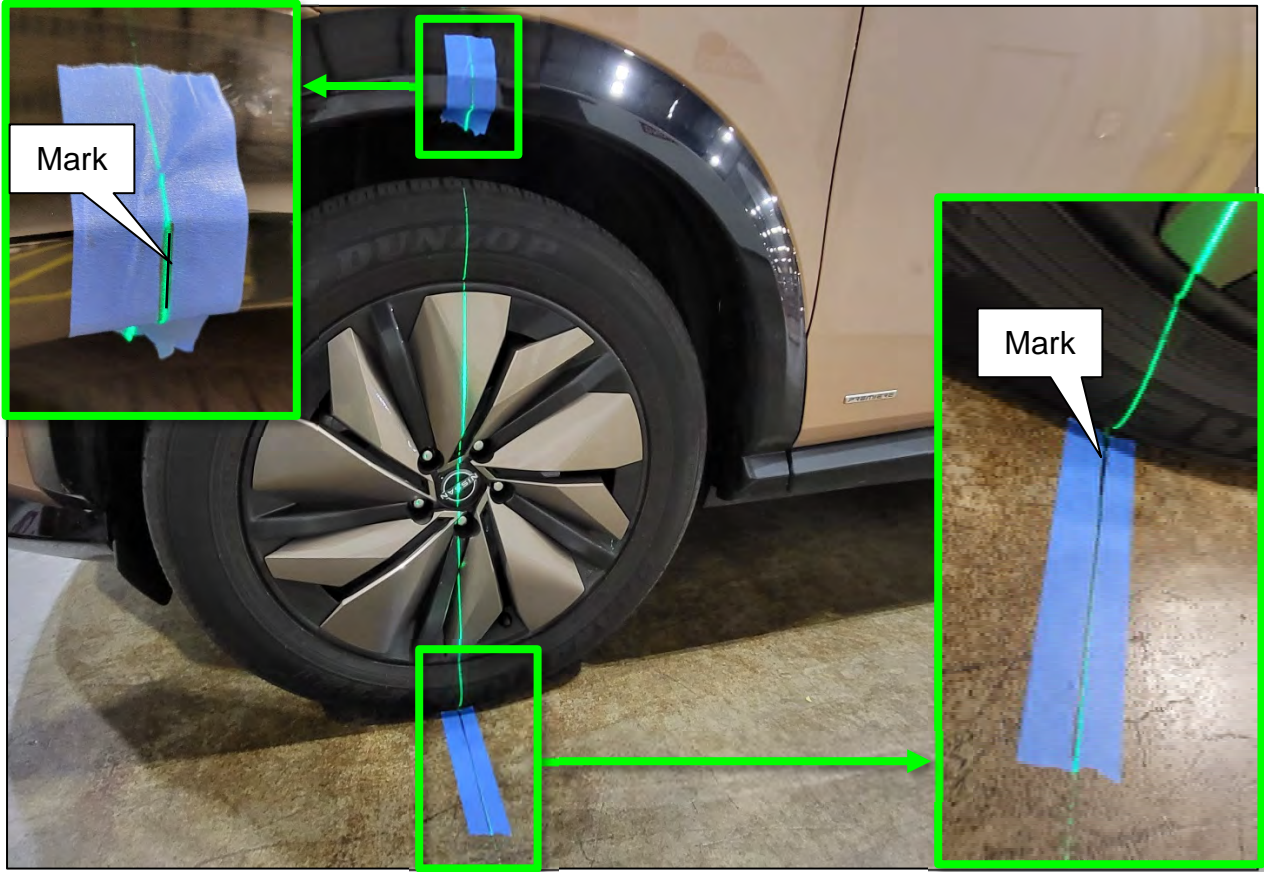

Figure 21

17. Move the laser so it is about 45° and approximately 800 mm (31.5 in.) from the wheel axle centerline.

HINT: The laser level can be either to the left or right of the wheel and tire assembly.



Figure 22

18. Line up the vertical laser line to the mark on the wheel arch (Figure 23), and then mark the floor with a cross-mark. This is the center point of the wheel and tire assembly (Figure 24).

HINT:

- The vertical laser line must line up with the line on the wheel arch, not the wheel center cap (Figure 23).
- To ensure the wheel center mark is not covered up by the bulge in the tire, ensure the vehicle is parked on a completely level area and the tires are properly inflated.



Figure 23

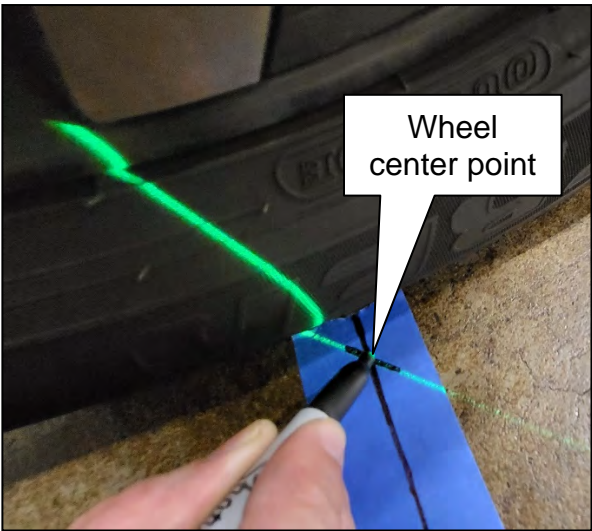

Figure 24

19. Repeat steps 14 - 18 starting on page 10, to mark the center point's at all four (4) wheel and tire assemblies.

Placing Calibration Targets for the Driver (LH) and/or Passenger (RH) Side Cameras

IMPORTANT: Steps 20 - 32 and the related figures show the driver (LH) side of the vehicle. The passenger (RH) side is similar. If the AVM Control Module was replaced, steps 20 - 32 must be performed for both the driver and passenger side cameras.

20. Place the laser level approximately 1500 mm (59 in.) behind the rear wheel (Figure 25), and then align the laser level so that the laser line is perfectly centered through the center points of both wheel and tire assemblies marked in step 18 on page 12.



Figure 25

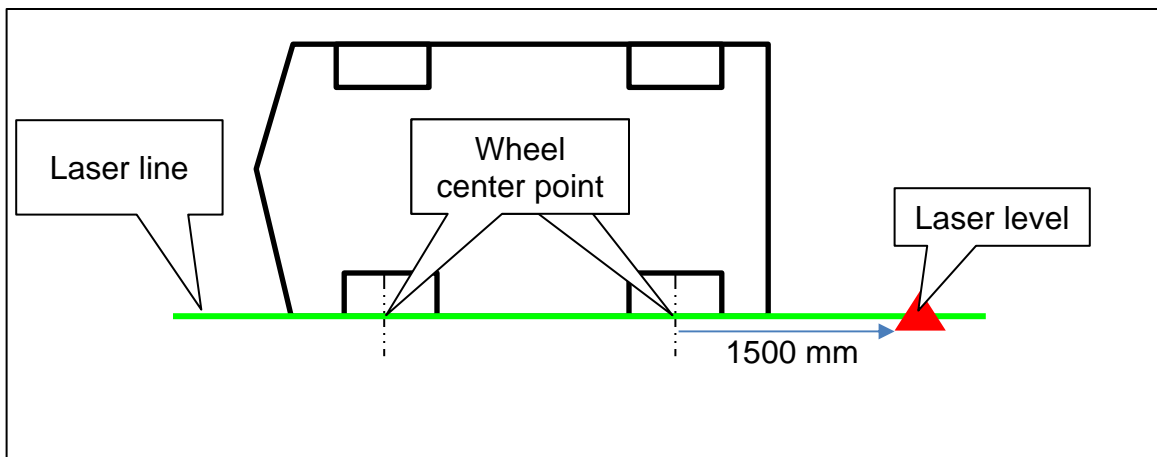

Figure 26

21. Activate a second vertical laser line (90° to the original laser line), and then mark a line at 500 mm and 2500 mm from the original laser line, as shown in Figure 27 and Figure 28.

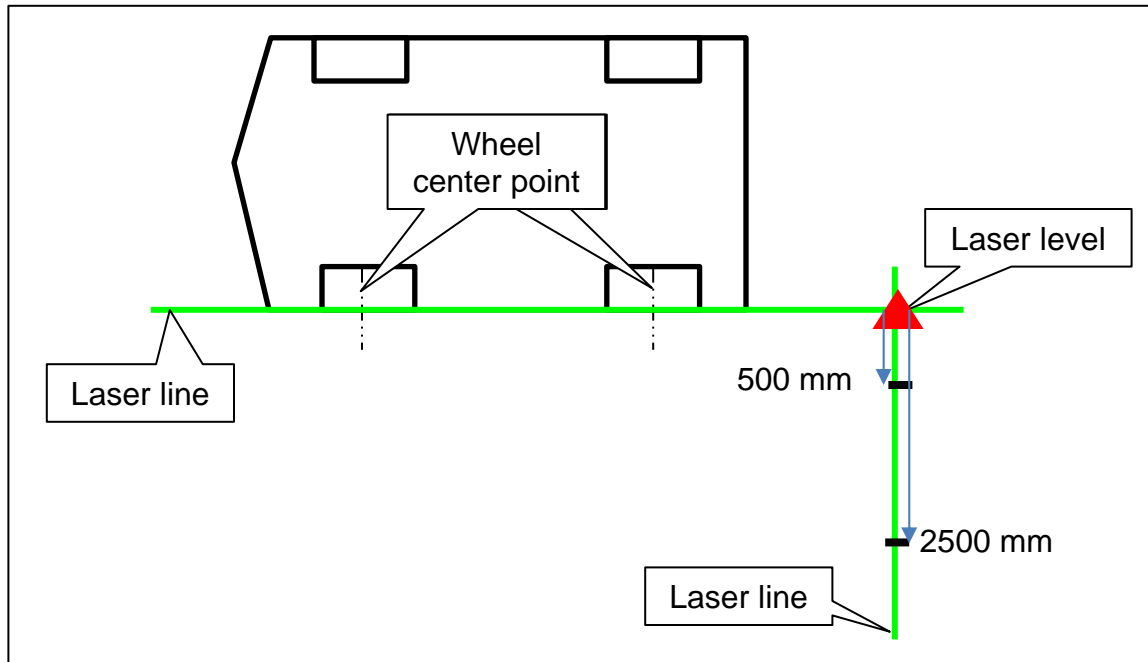

Figure 27

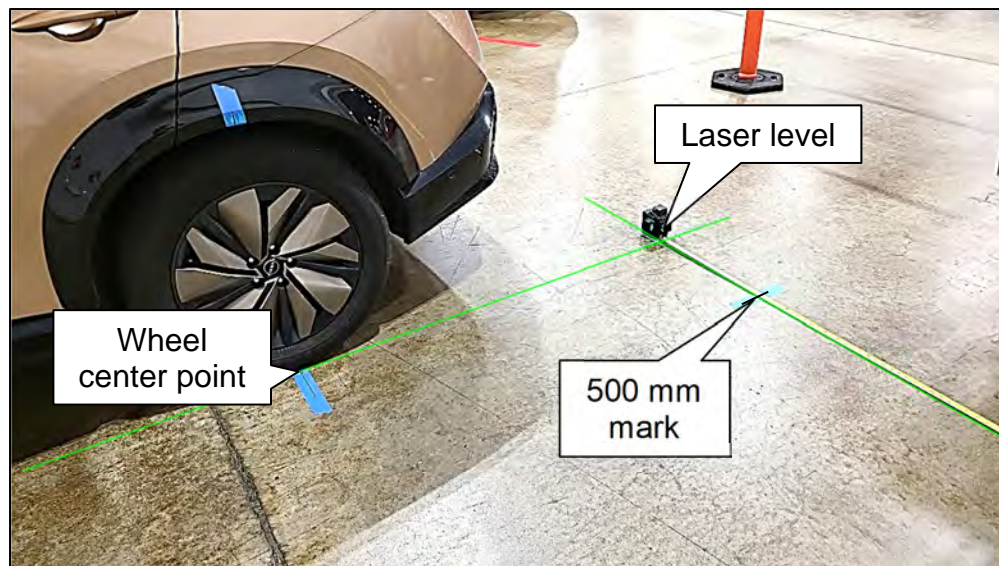

Figure 28

22. Repeat steps 20 - 21 starting on page 13, for the front of the vehicle.

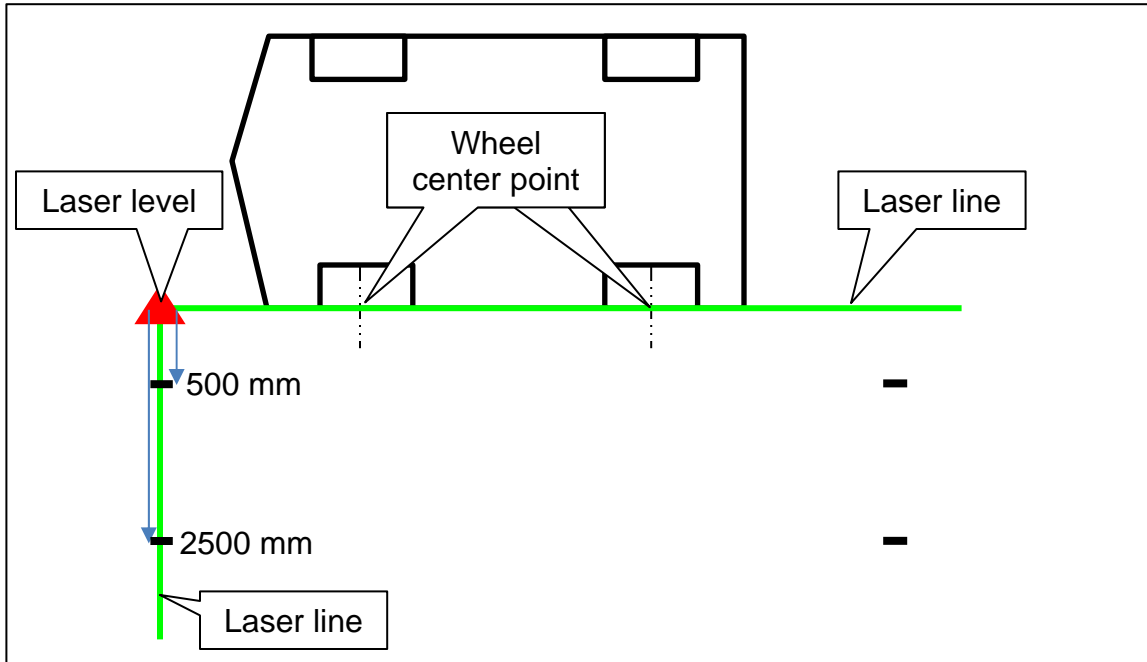

Figure 29

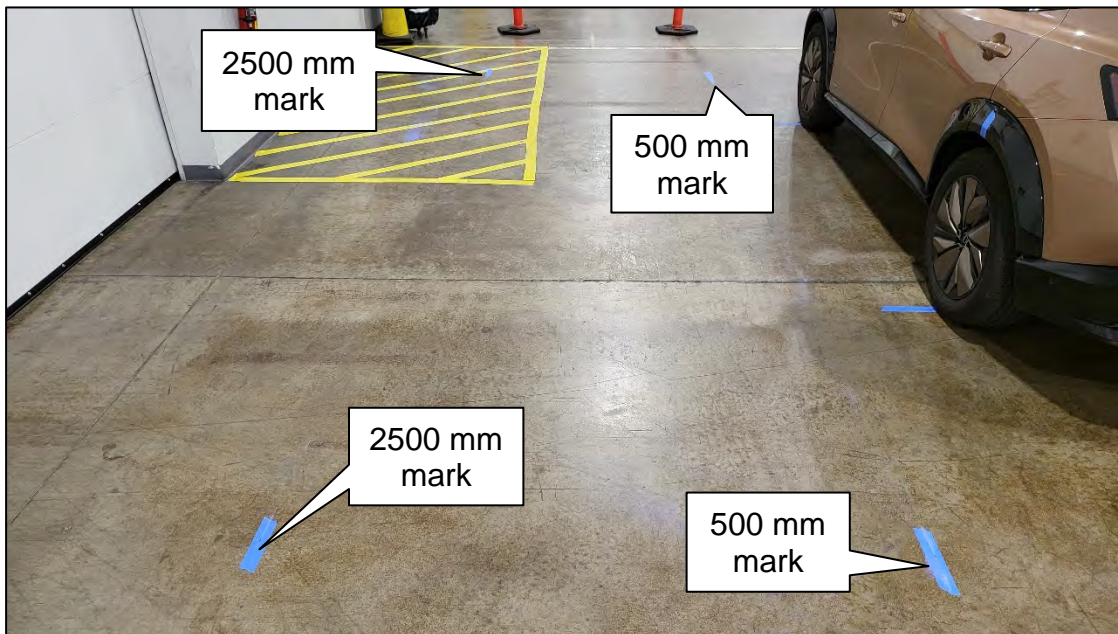

Figure 30

23. Use a chalk line tool to make a line between the 500 mm and 2500 mm marks, as shown in Figure 31 and Figure 32.

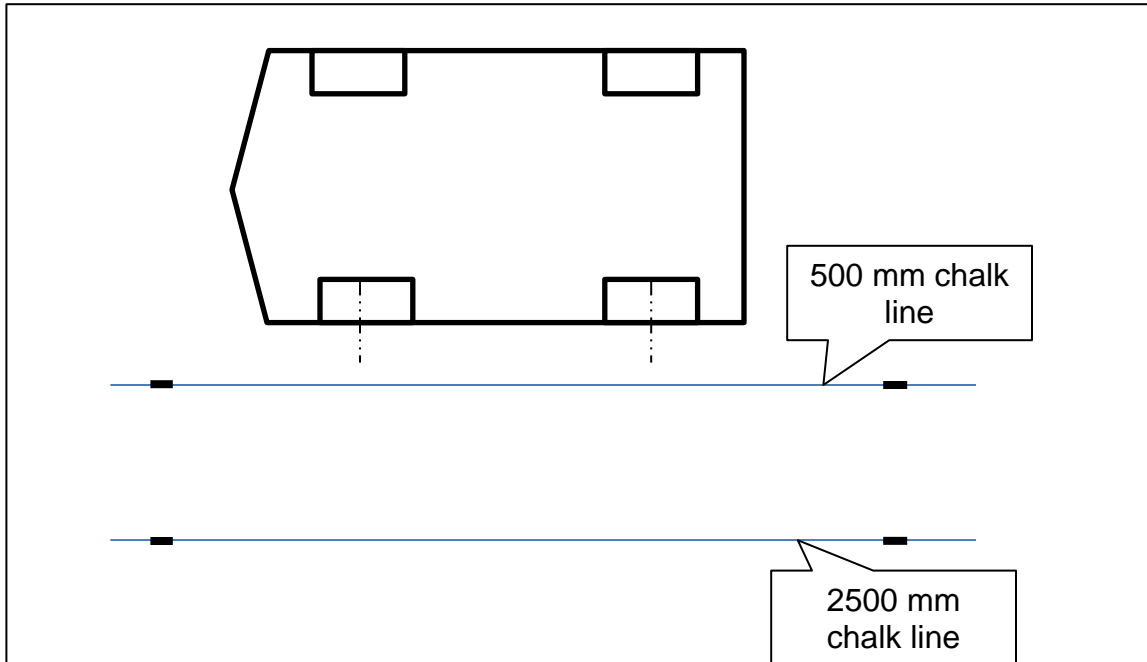

Figure 31

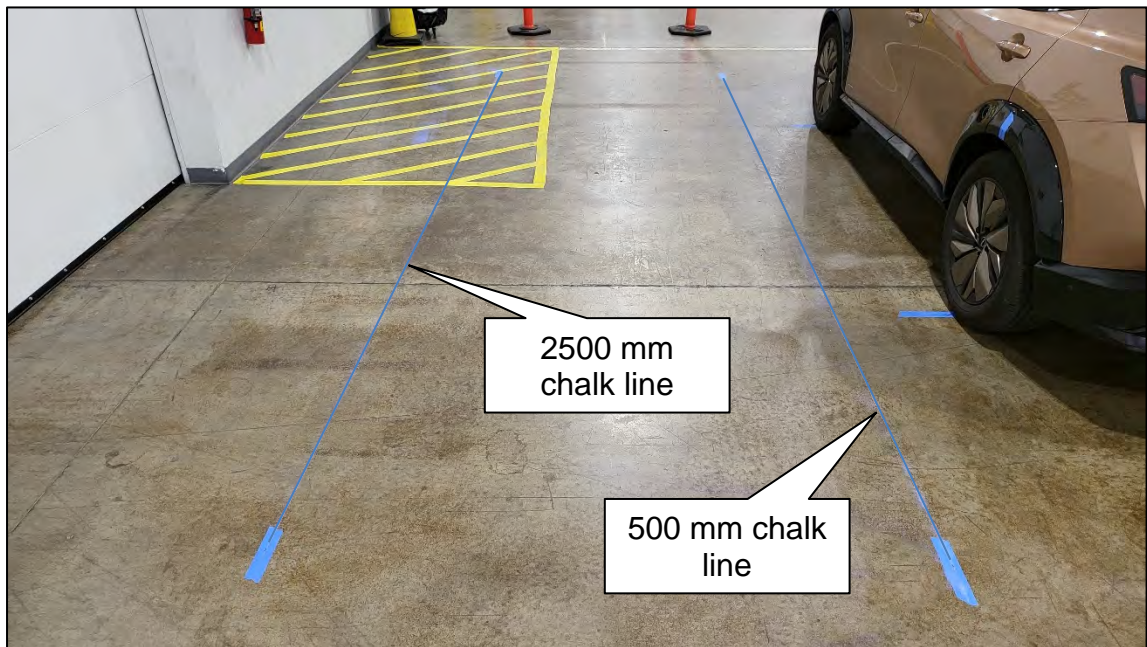

Figure 32

24. Place the laser level with both vertical lines activated, and align one laser line with the 500 mm chalk line and align the other laser line to the center point on the front driver (LH) side wheel, as shown in Figure 33 and Figure 34.

IMPORTANT: The laser line must be perfectly aligned with the 500 mm chalk line.

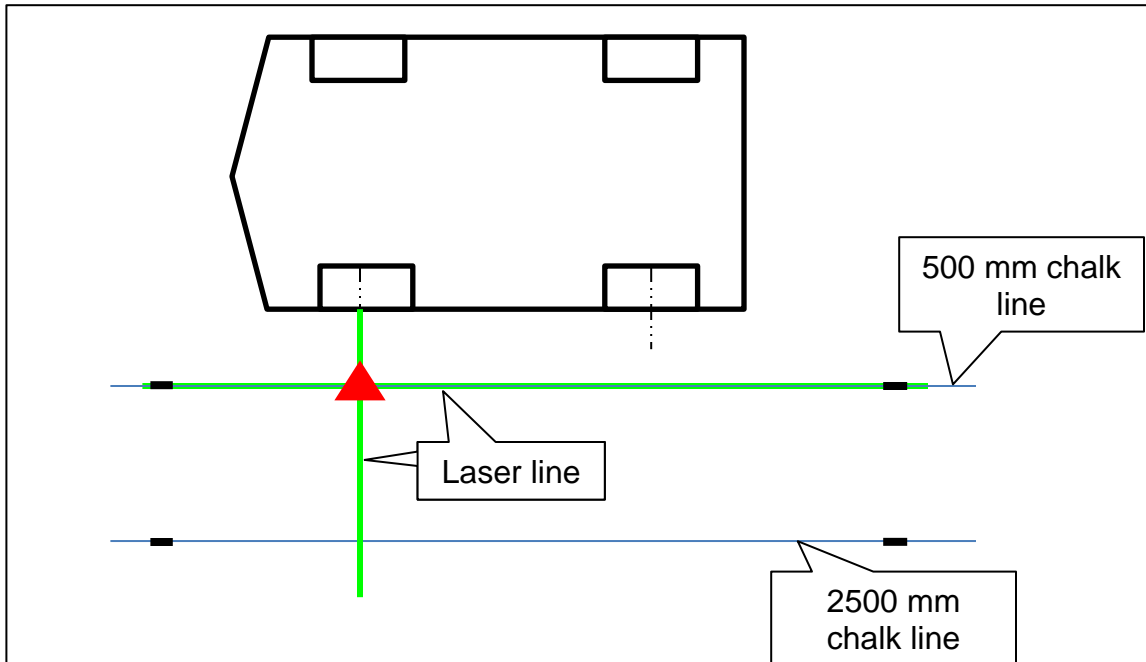

Figure 33

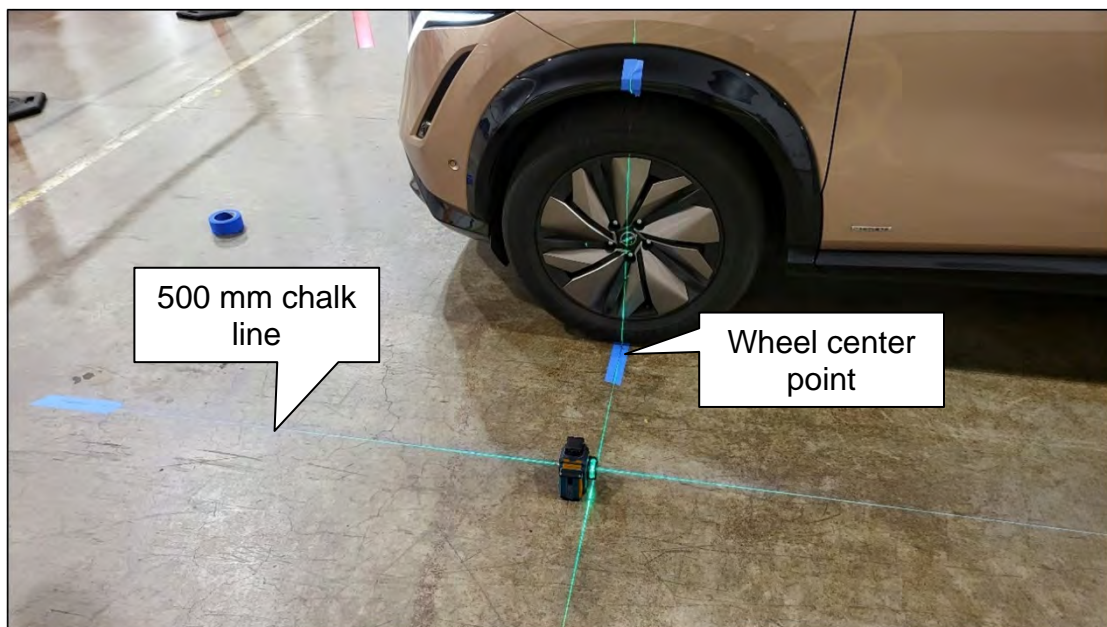

Figure 34

25. Place a mark on the floor below the laser line (Figure 36).

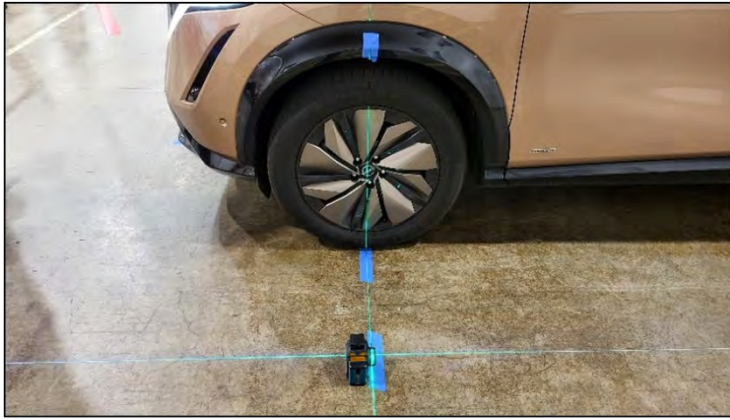

Figure 35

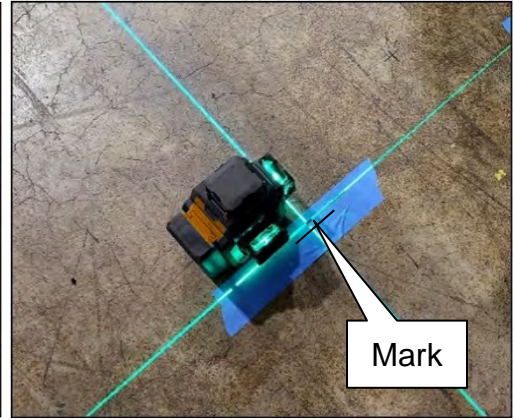

Figure 36

26. Measure and mark 1000 mm increments, as shown in Figure 37 and Figure 38.



Figure 37

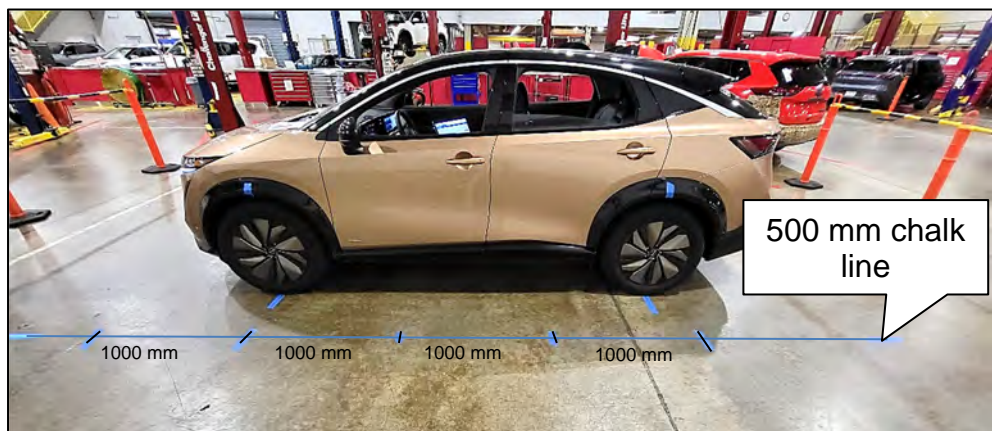

Figure 38

27. Move the laser level to the position shown in Figure 39, and then make a mark on the 2500 mm chalk line.

IMPORTANT: The laser line must be perfectly aligned with the 500 mm chalk line.

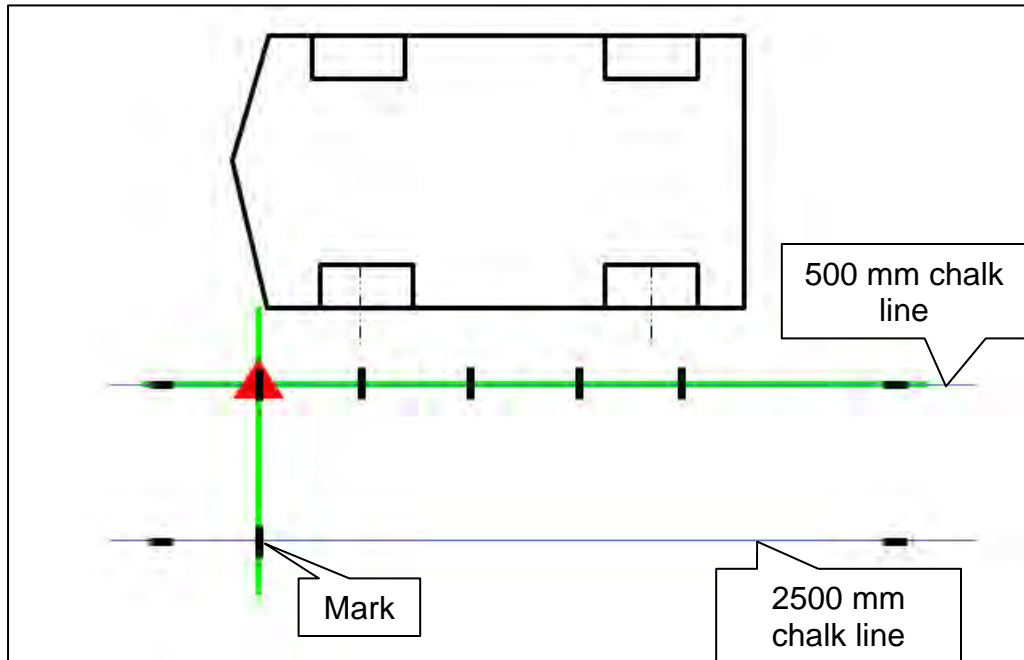

Figure 39

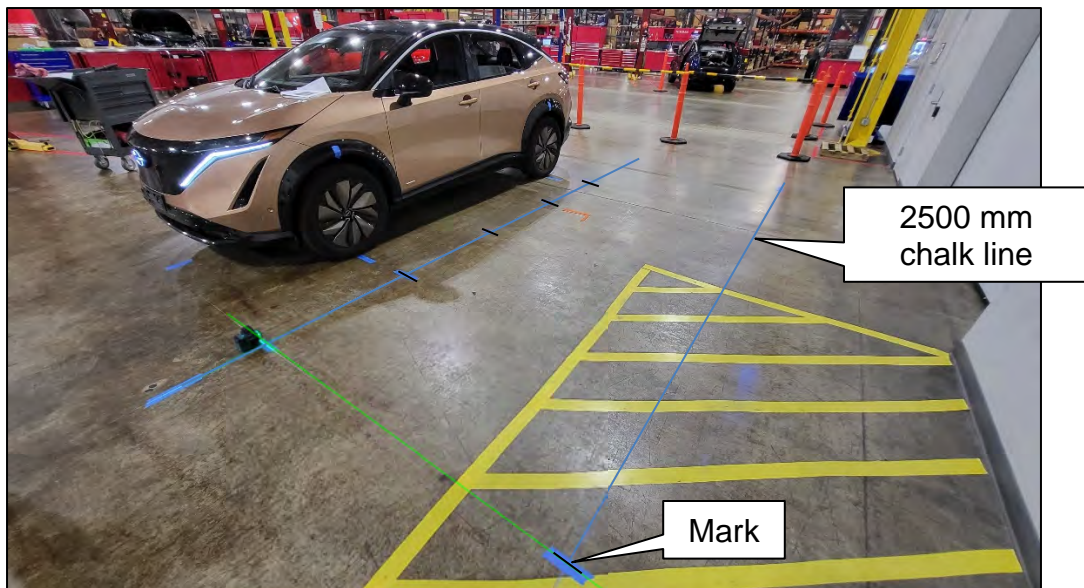

Figure 40

28. Move the laser level to the position shown in Figure 41, and then make a mark on the 2500 mm chalk line.

IMPORTANT: The laser line must be perfectly aligned with the 500 mm chalk line.

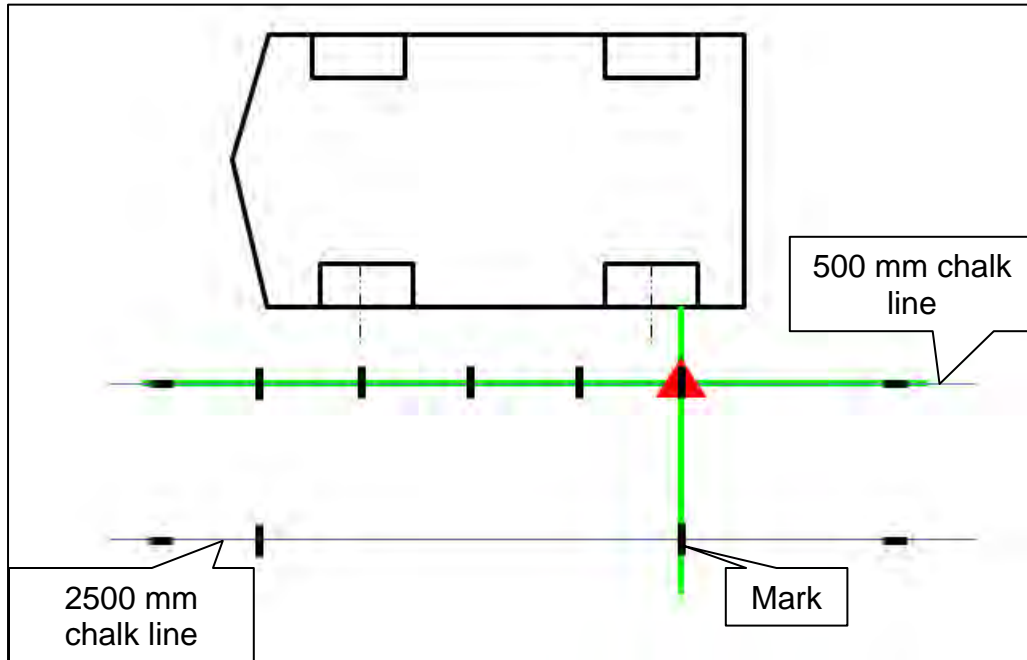

Figure 41

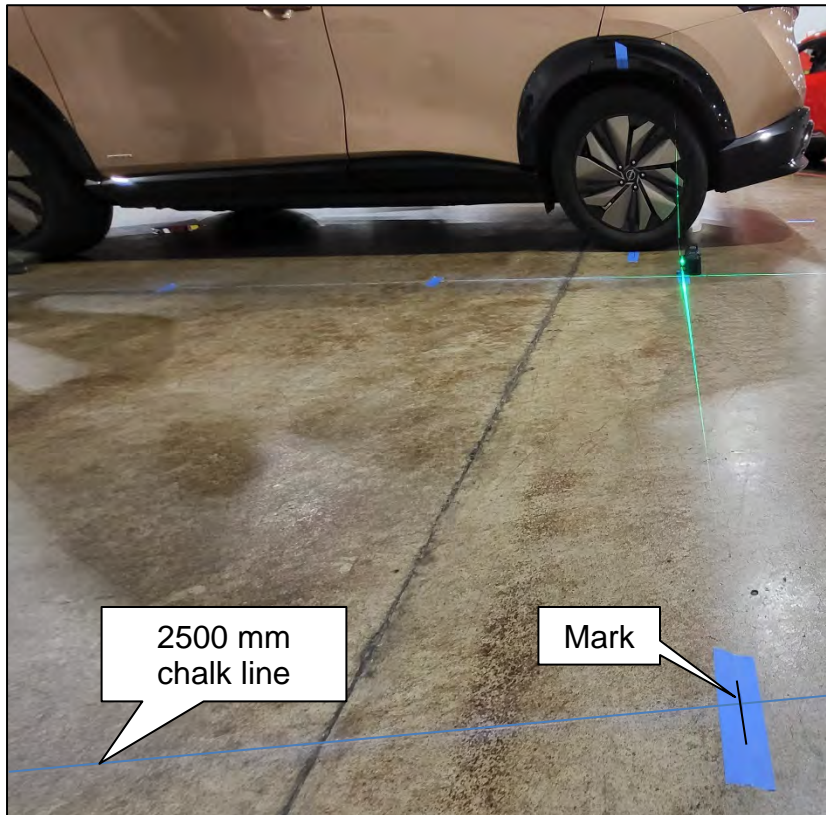

Figure 42

29. Using a carpenter's square, squared to the chalk line, extend each of the seven (7) marks 12 in. from the chalk line.

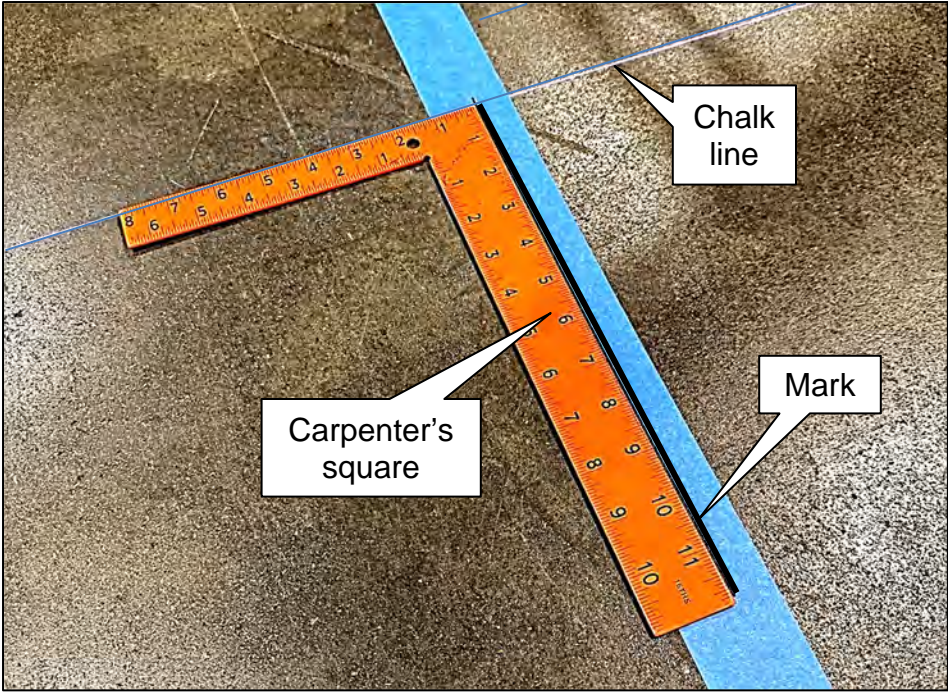

Figure 43

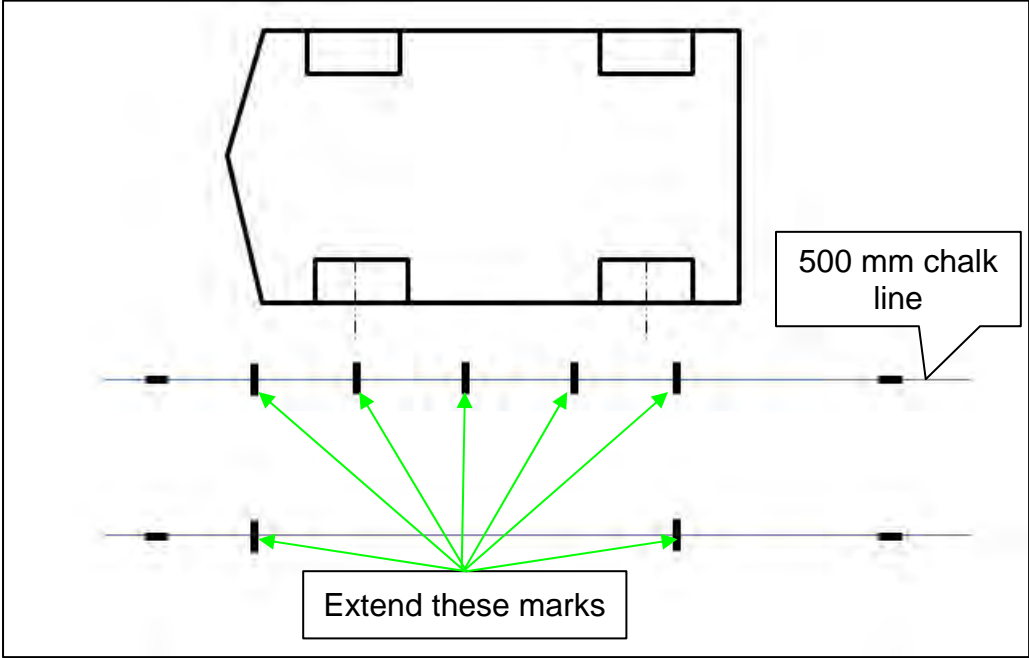

Figure 44

30. Place five (5) targets on the marks along the 500 mm chalk line.

IMPORTANT: Orient and align the targets, as shown in Figure 45, Figure 46 and Figure 47. The targets must be aligned with the 500 mm chalk line and the marks made in step 29 on page 21.

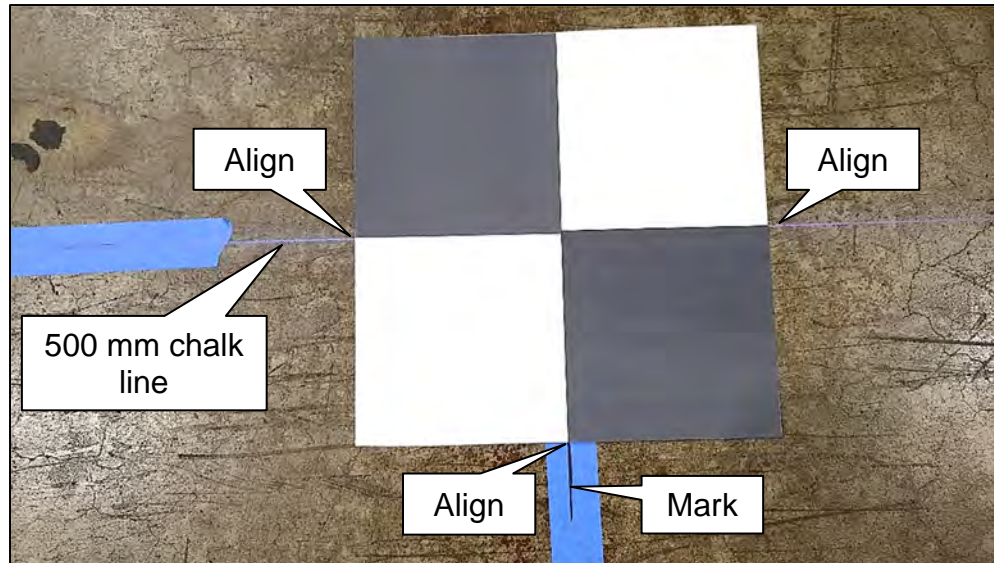

Figure 45

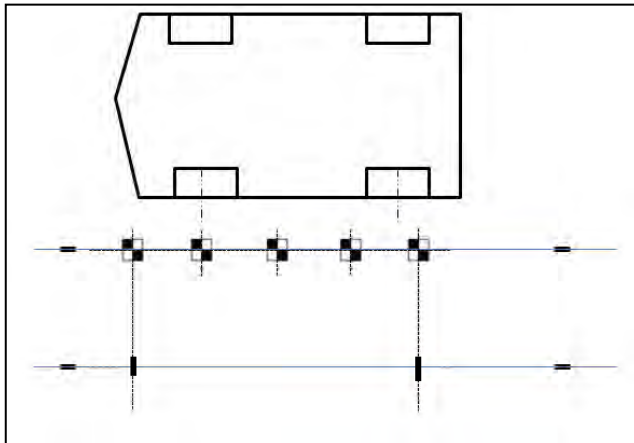

Figure 46



Figure 47

31. Place one (1) target on the forward most mark on the 2500 mm chalk line.

IMPORTANT: Orient and align the target, as shown in Figure 48, Figure 49 and Figure 50. The target must be aligned with the 2500 mm chalk line and the mark made in step 29 on page 21.

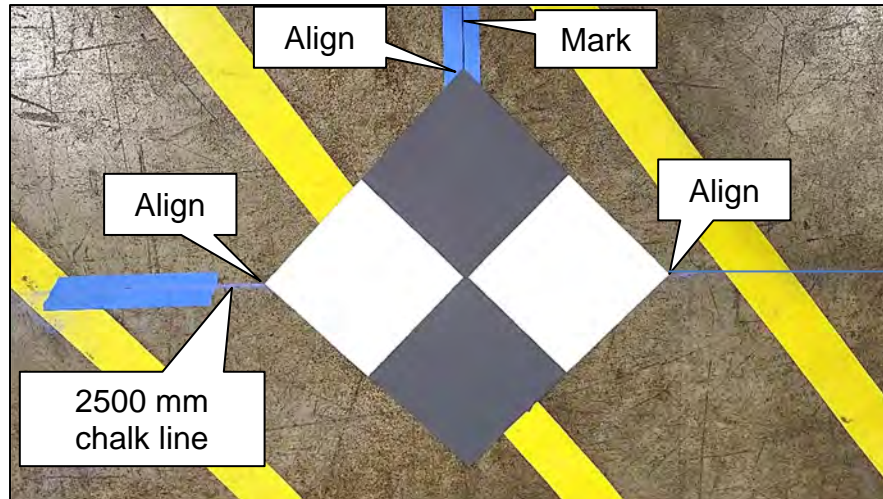

Figure 48

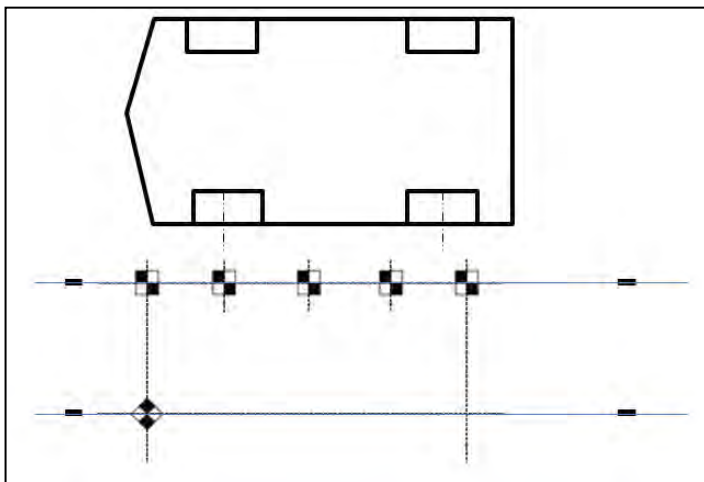

Figure 49



Figure 50

32. Place one (1) target on the rearward most mark on the 2500 mm chalk line.

IMPORTANT: Orient and align the target, as shown in Figure 51, Figure 52 and Figure 53. The target must be aligned with the 2500 mm chalk line and the mark made in step 29 on page 21.

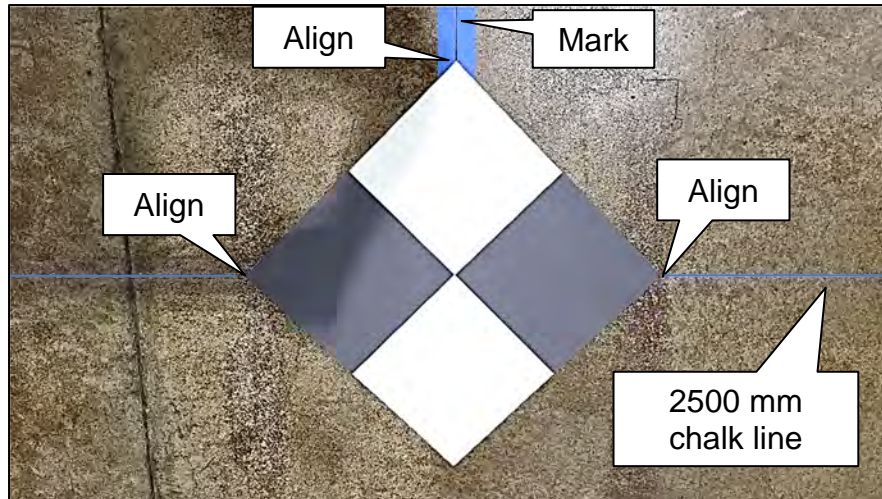

Figure 51

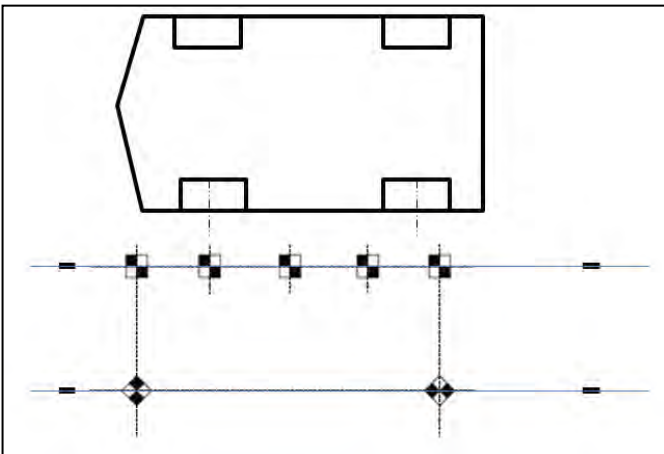

Figure 52



Figure 53

33. If the passenger (RH) side camera was replaced, repeat steps 20 - 32 starting on page 13, to place the calibration targets for the passenger (RH) side camera.

Driver (LH) Side Camera Calibration Measurements

34. Measure the distance between the wheel center point and the center of the calibration targets T1, T6, T7, and T5, as shown in Figure 54 below.

IMPORTANT: All measurements must be in millimeters (mm). Refer to the illustrations in Figure 54 to ensure the correct measurement is documented in the correct order and for each calibration target.

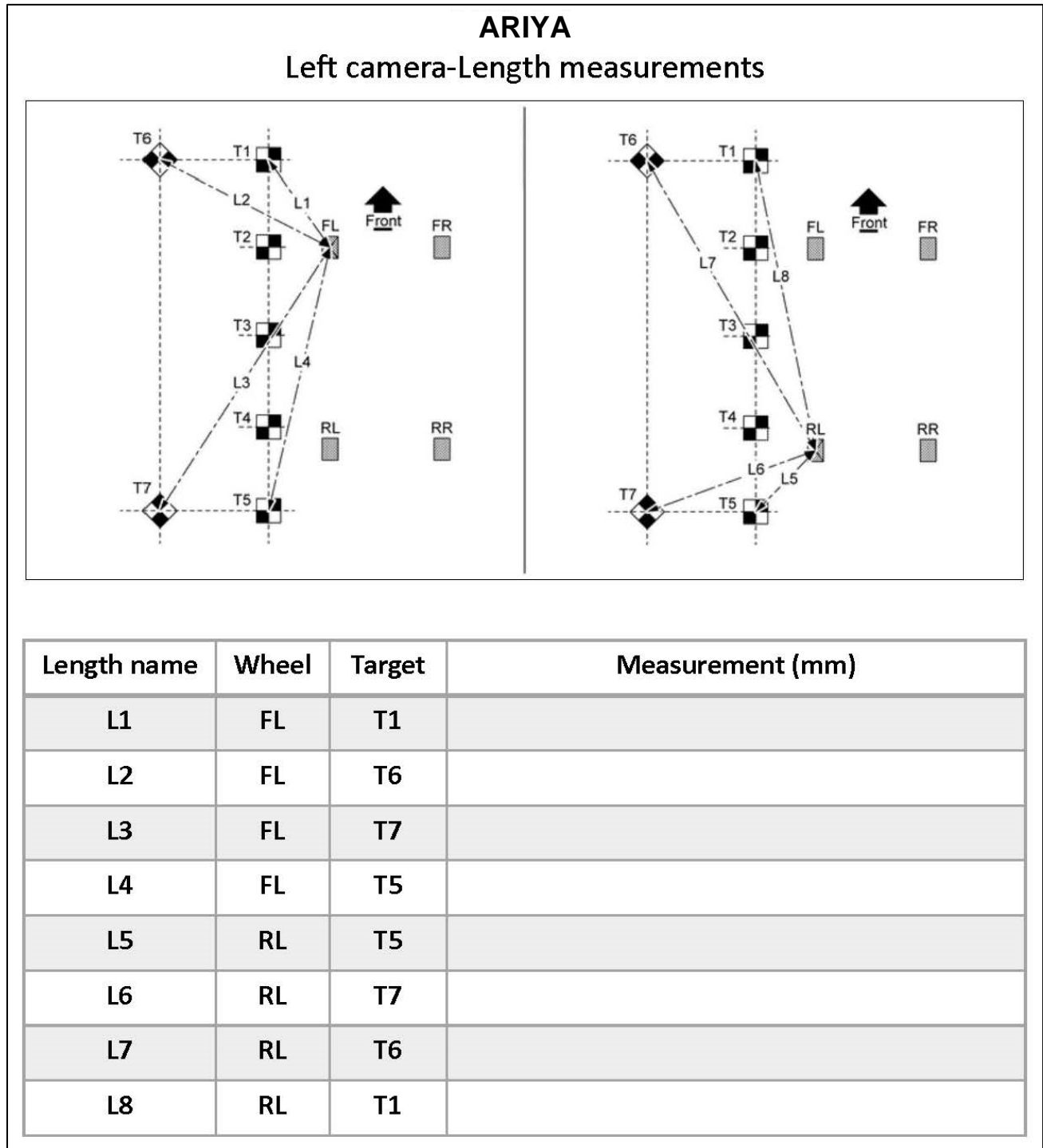

Figure 54

35. Place the laser level on a clean cloth, and then on the roof of the vehicle.

IMPORTANT:

- Place the laser level in the middle of the vehicle's roof.
- The laser level must be still (no fans should be blowing).



Figure 55



Figure 56

IMPORTANT: For steps 36 and 37:

- When holding the carpenter's wooden folding ruler (carpenter's ruler), ensure the ruler is completely upright and does not bend.
- All measurements must be in millimeters (mm).
- Refer to the illustrations in Figure 59 on page 27 to ensure the correct measurement is documented in the correct order and for each calibration target.

36. Using a folding carpenter's ruler, measure the height from the center of each calibration target, and then record the measurements H1-H7 in the table in Figure 59 on page 27.

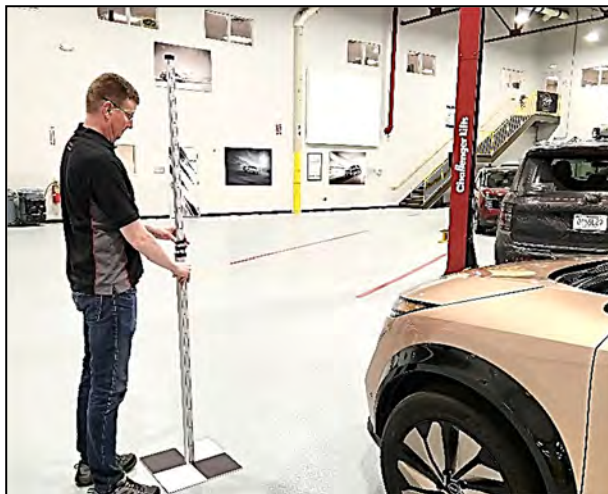

Figure 57



Figure 58

37. Using a folding carpenter's ruler, measure the height from the wheel center point, and then record the measurements H8-H11 in the table in Figure 59 on page 27.

ARIYA Left camera-Height measurements

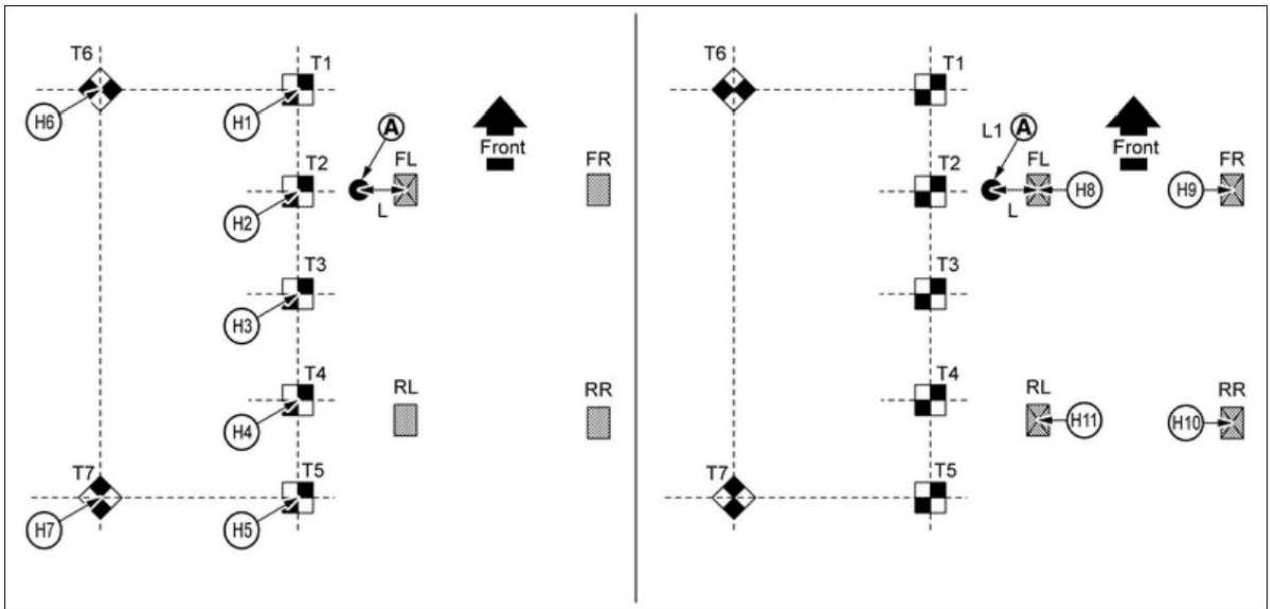

Height name	Wheel	Target	Measurement (mm)
H1	-	T1	
H2	-	T2	
H3	-	T3	
H4	-	T4	
H5	-	T5	
H6	-	T6	
H7	-	T7	
H8	FL	-	
H9	FR	-	
H10	RR	-	
H11	RL	-	

Figure 59

Passenger (RH) Side Camera Calibration Measurements

38. Measure the distance between the wheel center point and the center of the calibration targets T1, T6, T7, and T5, as shown in Figure 60 below.

IMPORTANT: All measurements must be in millimeters (mm). Refer to the illustrations in Figure 60 to ensure the correct measurement is documented in the correct order and for each calibration target.

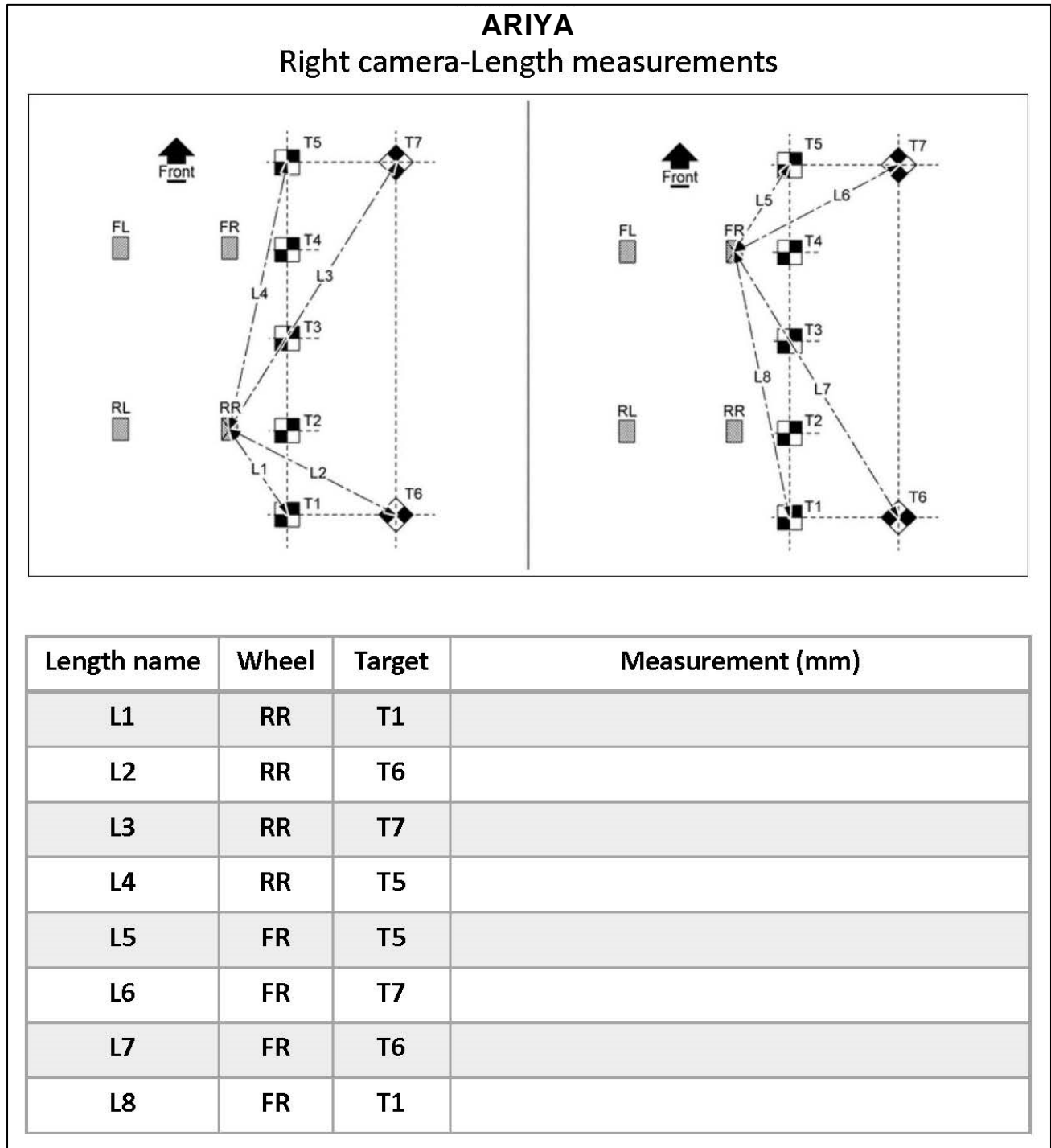

Figure 60

39. Refer to steps 35 - 37 on page 26 to set up the laser level to measure the height of the passenger (RH) side camera, and then document the measurements in Figure 61.

IMPORTANT: All measurements must be in millimeters (mm). Refer to the illustrations in Figure 61 to ensure the correct measurement is documented in the correct order and for each calibration target.

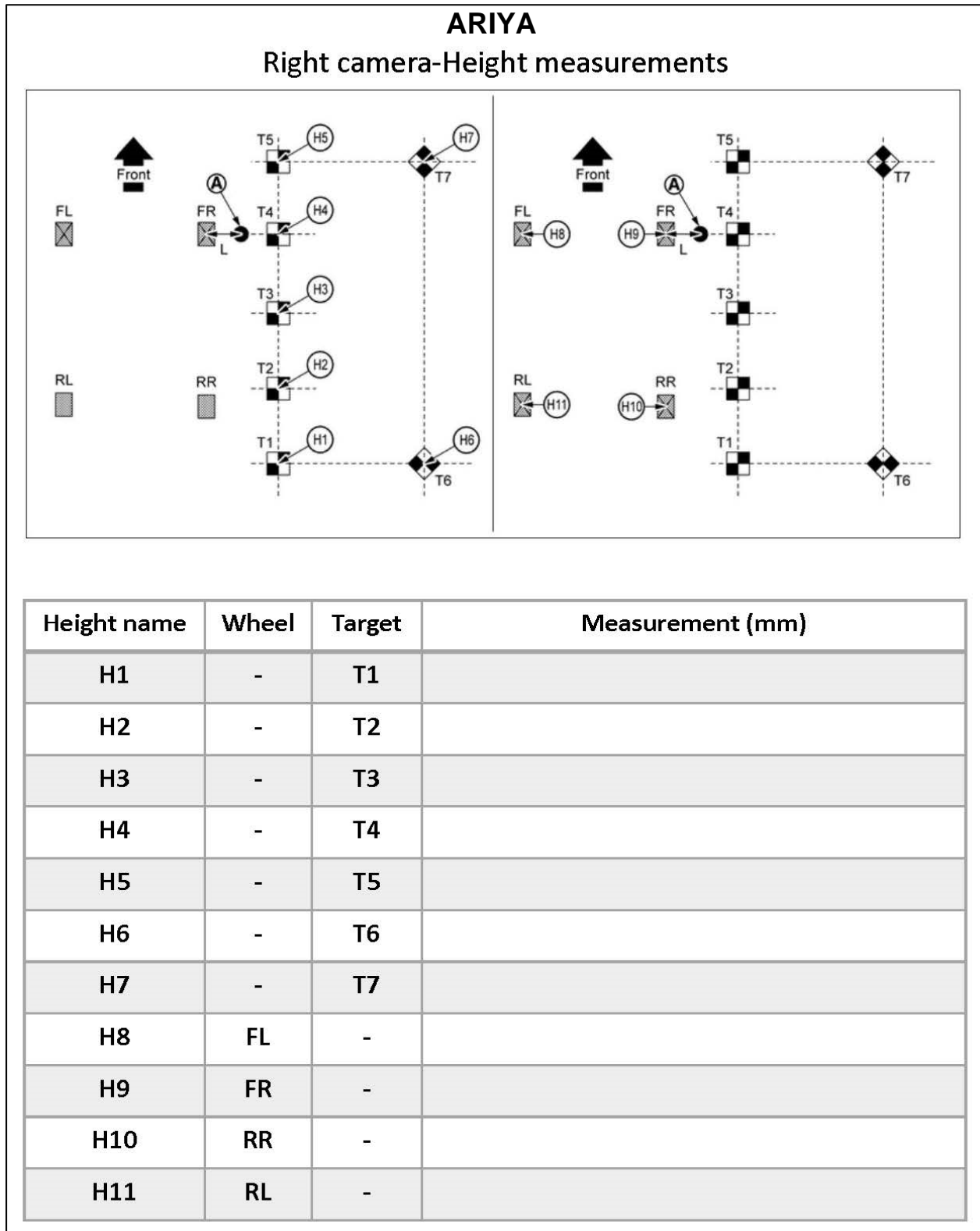

Figure 61

Marking the Center Point for the Front of the Vehicle

40. Place the laser level approximately 800 mm (31.5 in.) from the front of the vehicle and align the laser with the front camera, as shown in Figure 63.

IMPORTANT: Be sure to center the laser line with the front camera and not the “NISSAN” brand name on the emblem.

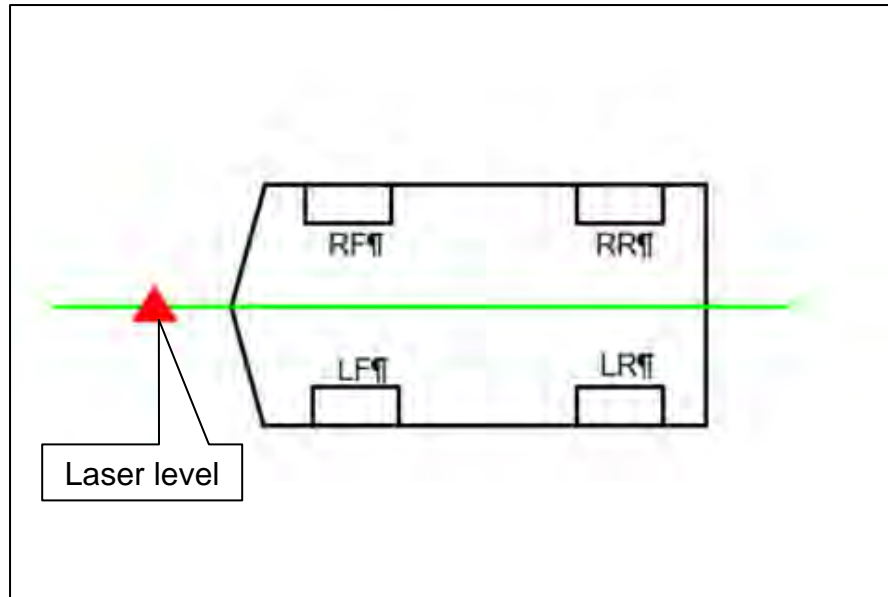

Figure 62

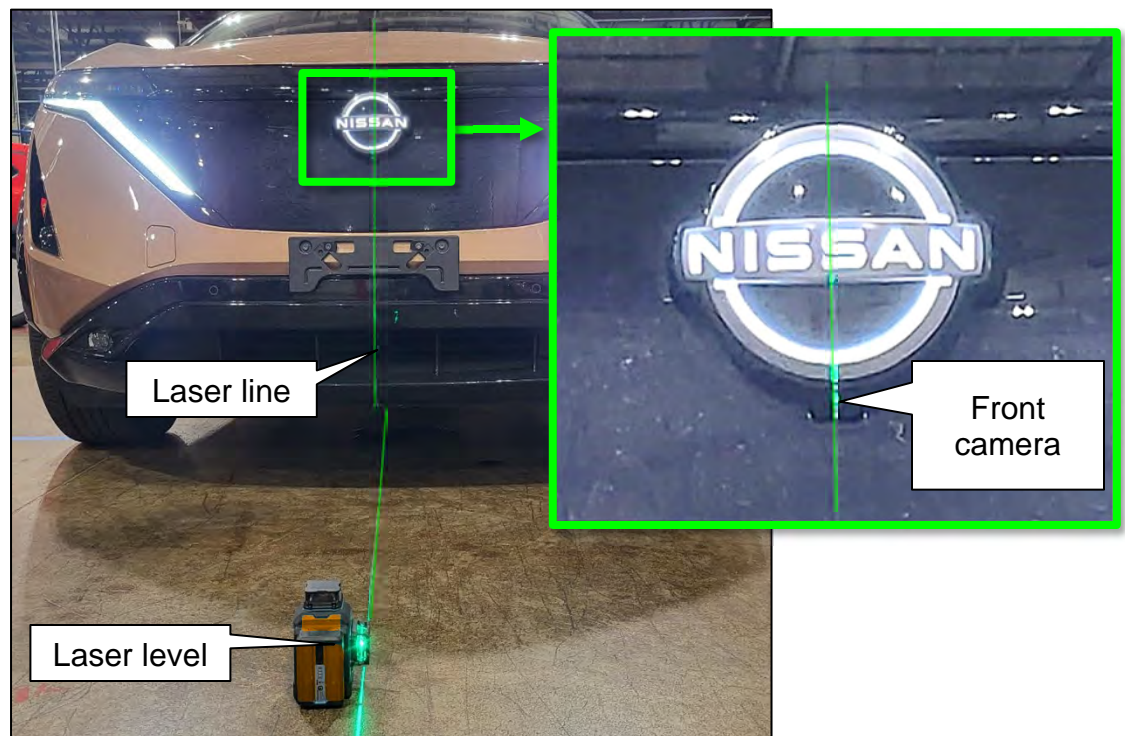

Figure 63

41. Mark the NISSAN emblem and the floor near the front fascia.



Figure 64

42. Move the laser so it is about 45° and approximately 800 mm (31.5 in.) from the front of the vehicle, and then line up the vertical laser line to the mark on the NISSAN emblem.

HINT: The laser level can be either to the left or right of the front of the vehicle.

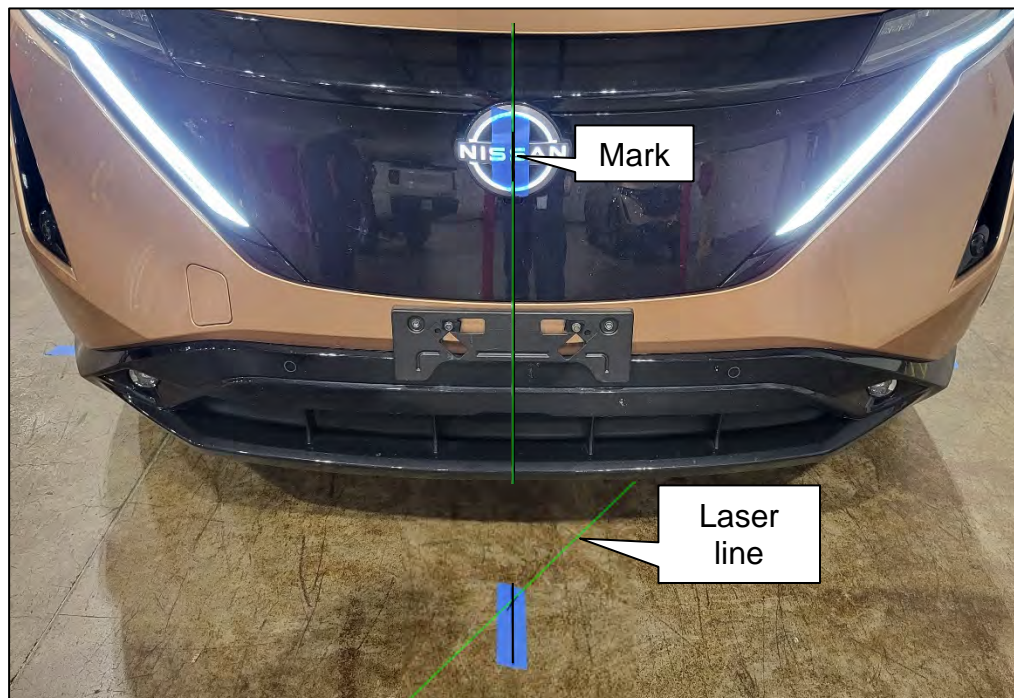

Figure 65

43. Mark the floor with a cross-mark, denoting the center point of the front of the vehicle.

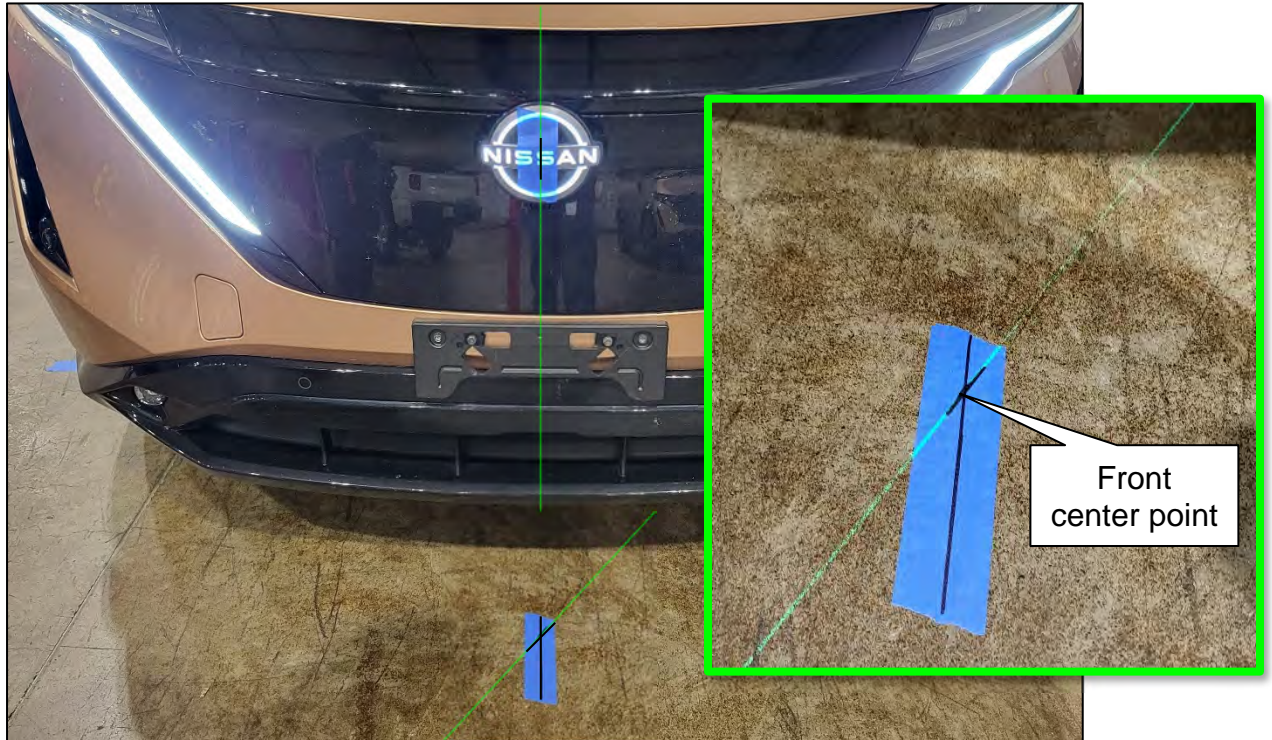

Figure 66

Marking the Center Point for the Rear of the Vehicle

44. Place the laser level approximately 800 mm (31.5 in.) from the rear of the vehicle and align the laser with the center mark at the front of the vehicle and the circle in between the S's in NISSAN, as shown in Figure 68.

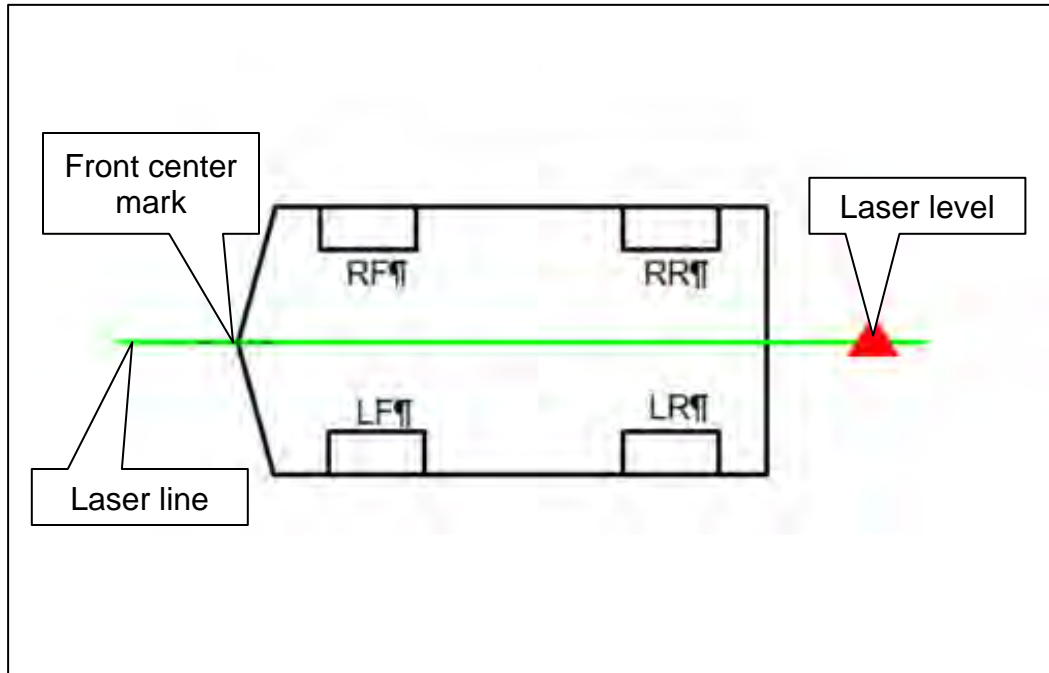

Figure 67

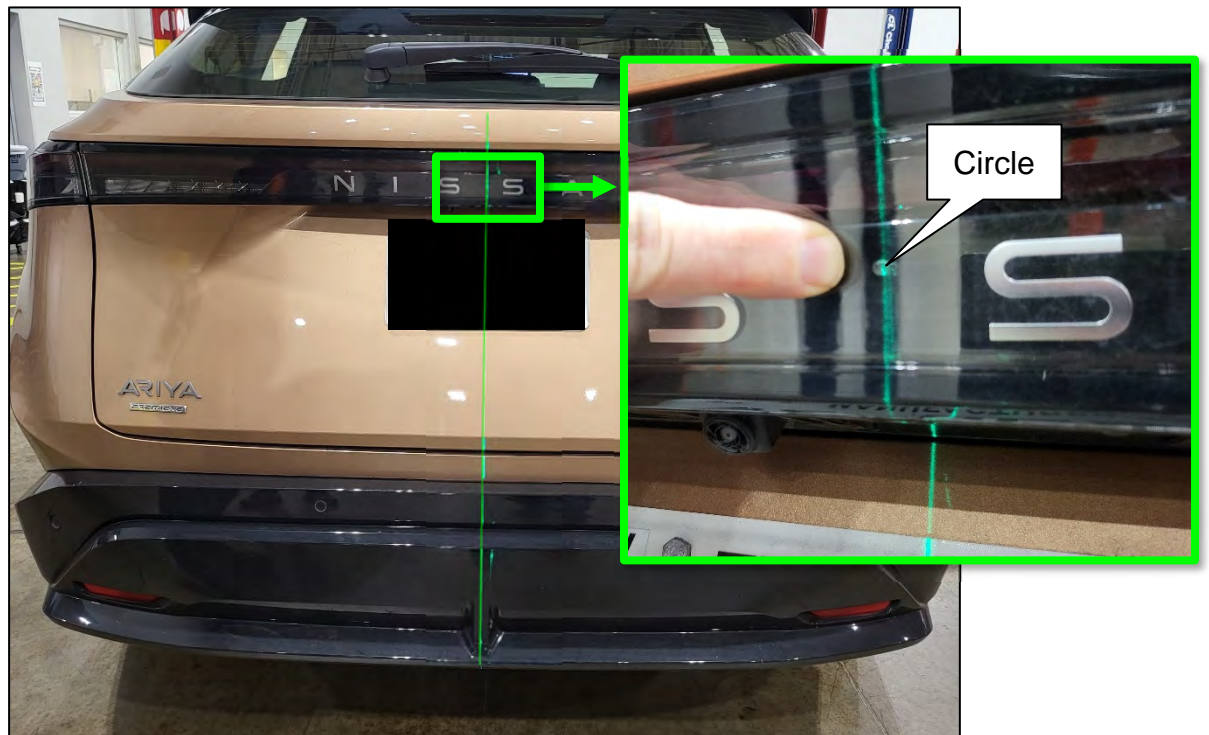

Figure 68

45. Mark the rear fascia, where shown in Figure 69, and the floor near the rear fascia.

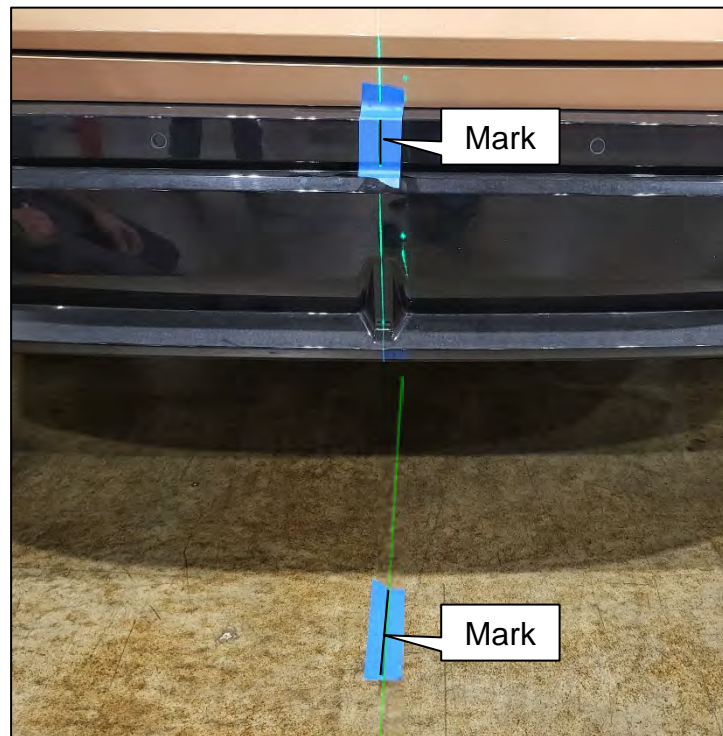

Figure 69

46. Move the laser so it is about 45° and approximately 800 mm (31.5 in.) from the rear of the vehicle, and then line up the vertical laser line to the mark on the rear fascia.

HINT: The laser level can be either to the left or right of the front of the vehicle.

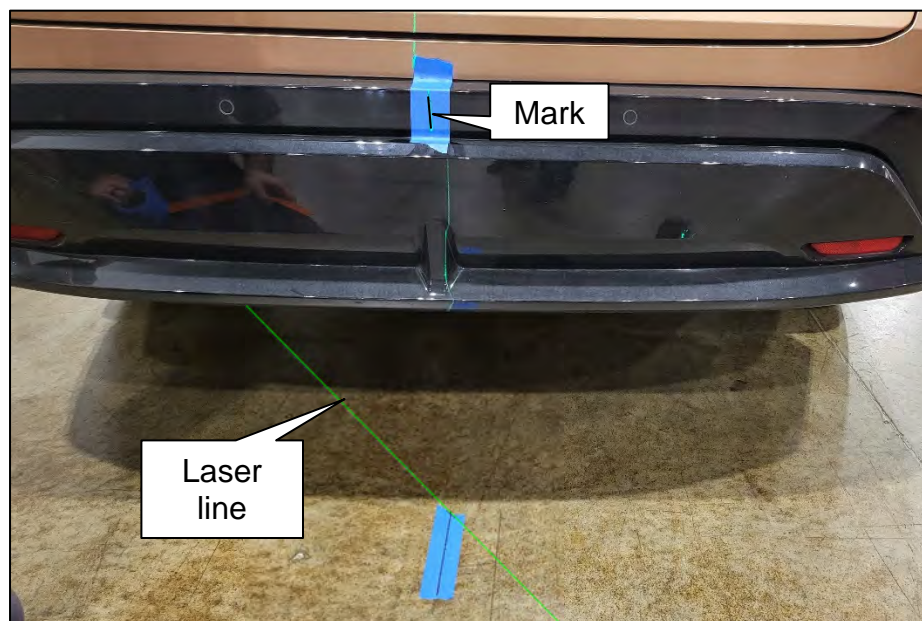

Figure 70

47. Mark the floor with a cross-mark, denoting the center point of the rear of the vehicle.

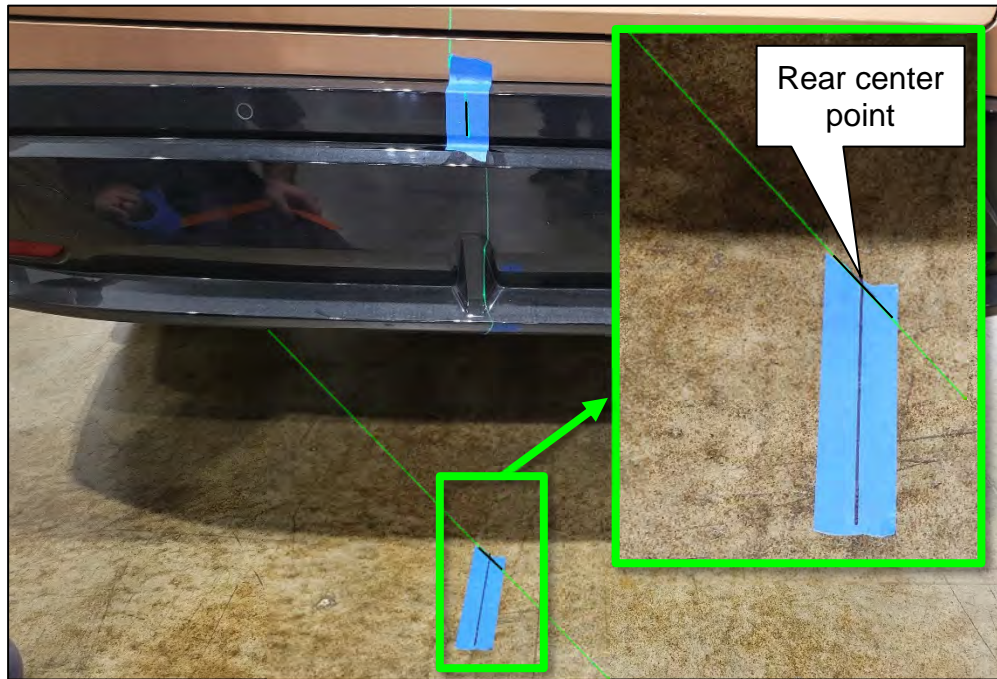

Figure 71

Placing Calibration Targets for the Front and/or Rear Cameras

IMPORTANT: Steps 48 - 62 and the related figures show the rear of the vehicle. The front is similar. If the AVM Control Module was replaced, steps 48 - 62 must be performed for both the front and rear cameras.

48. Place the laser level 2500 mm from the rear center point of the vehicle, and then align the laser line with both the front and rear center points, as shown in Figure 72 and Figure 73.

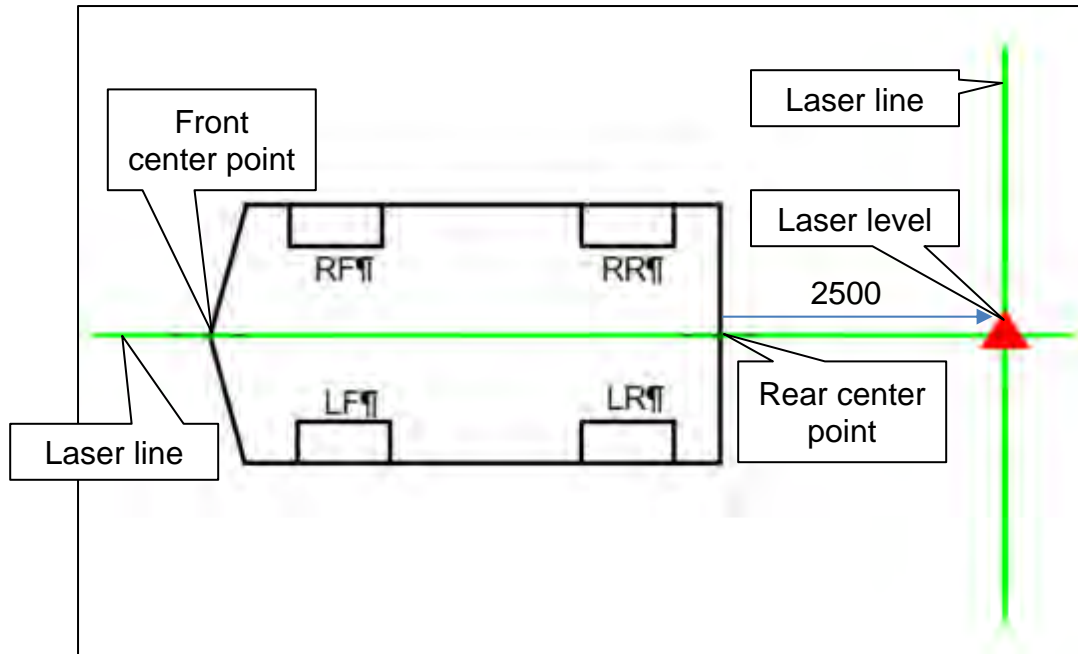

Figure 72



Figure 73

49. Place a cross-mark on the floor below the laser line (Figure 36).

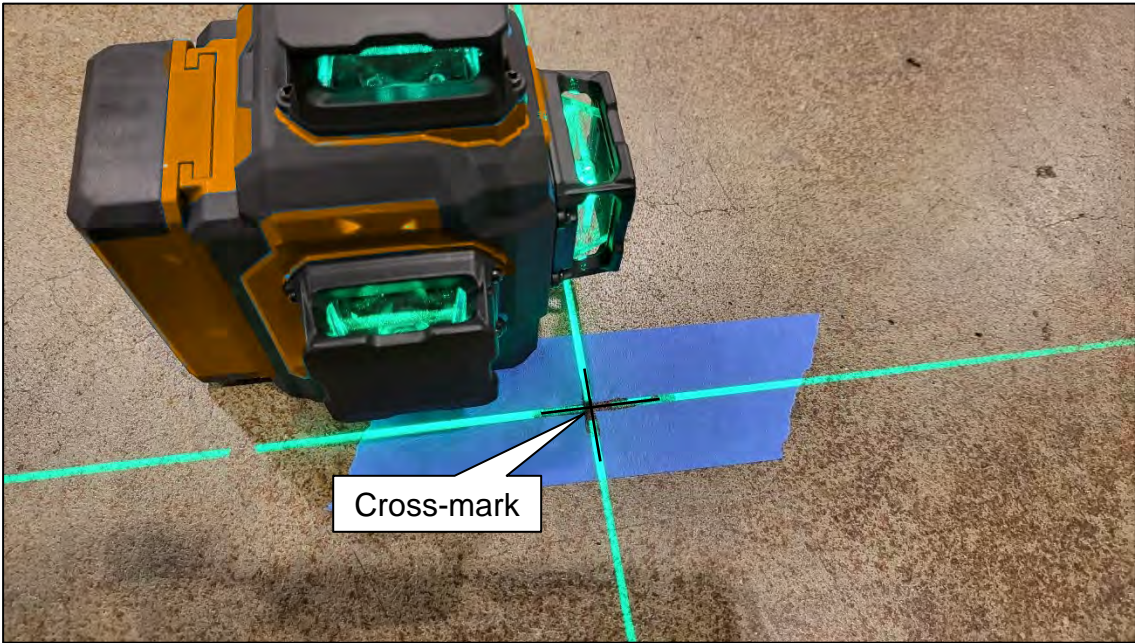

Figure 74

50. Measure and place a mark 500 mm from the rear center point.

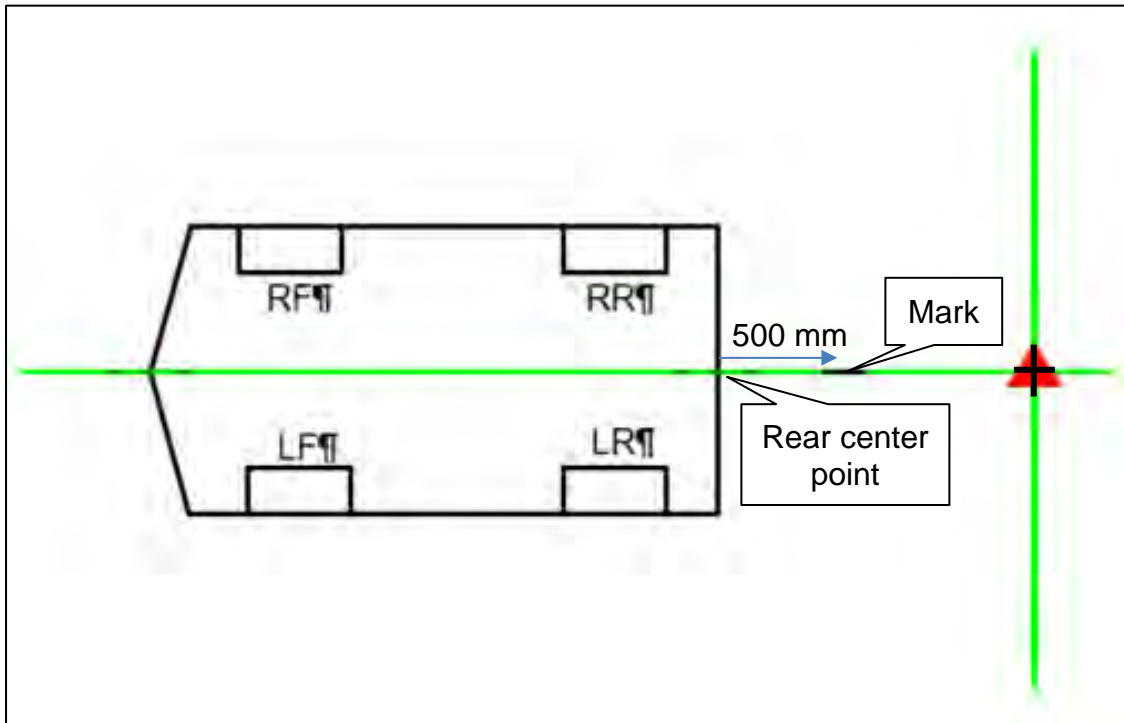

Figure 75

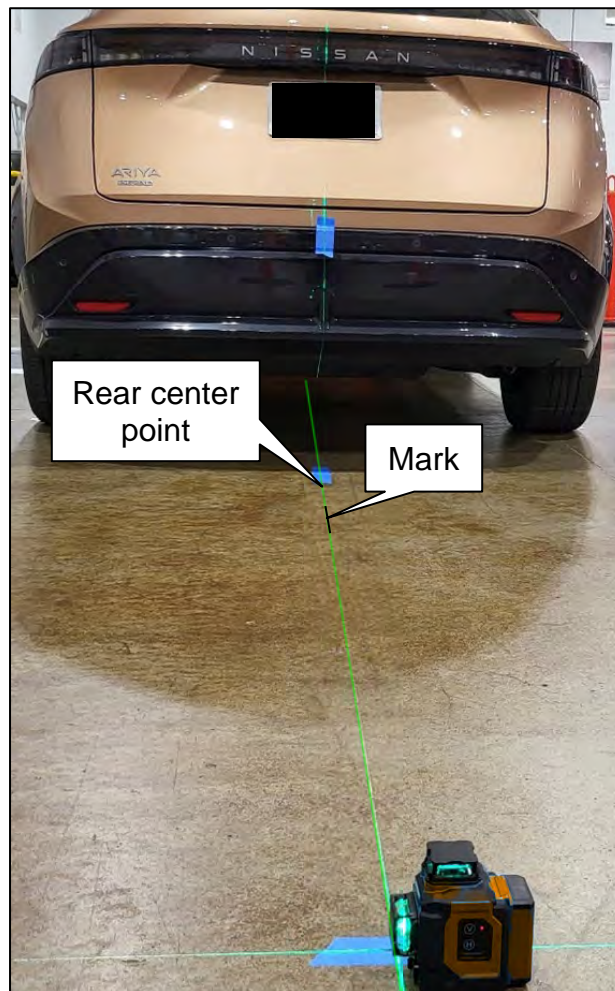

Figure 76

51. Measure and place a mark 2500 mm to the left and to the right of the laser level, as shown in Figure 77.

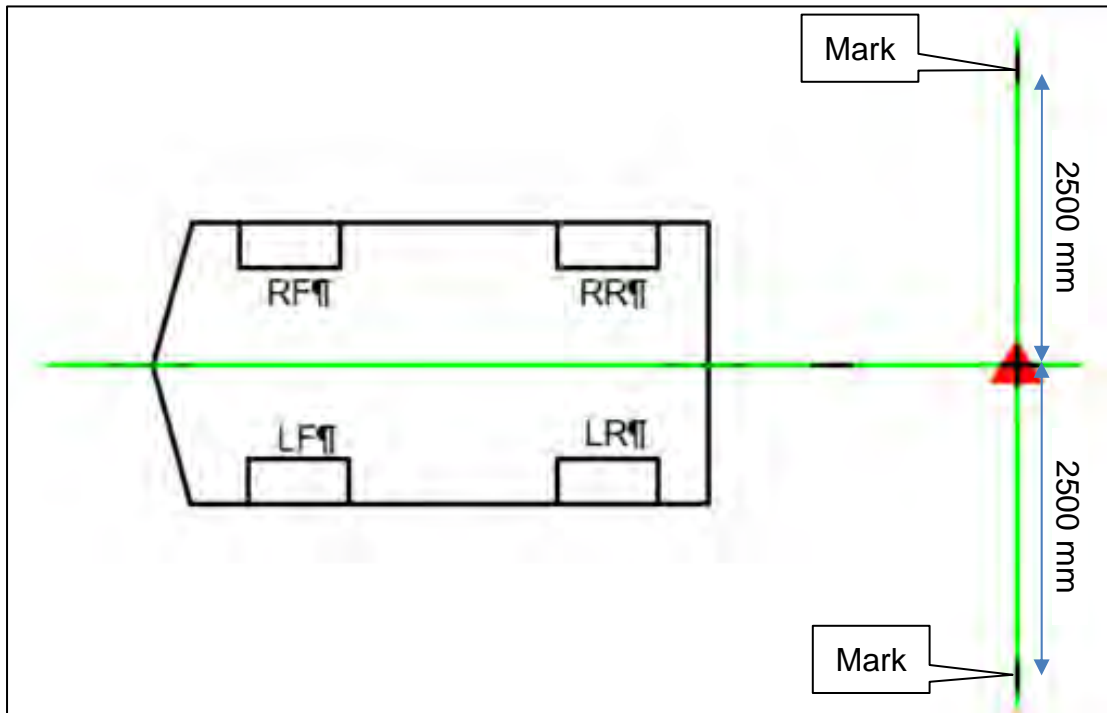

Figure 77

52. Move the laser to the 500 mm mark, and then measure and place a mark 2500 mm to the left and to the right of the laser level, as shown in Figure 78 and Figure 79.

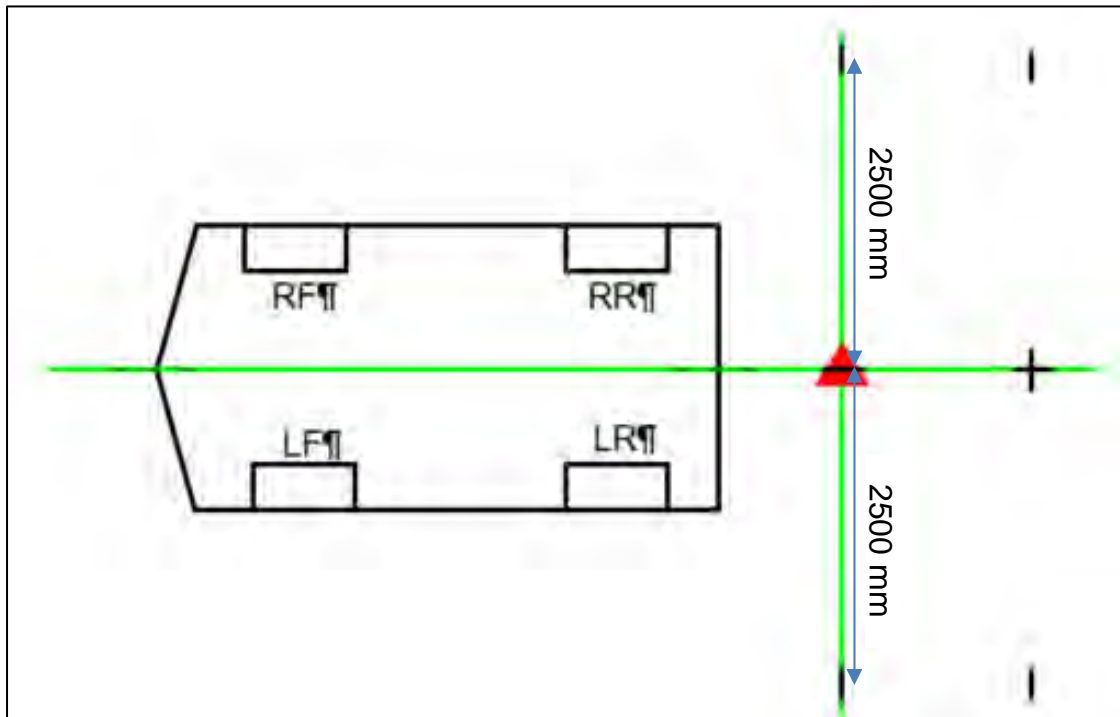

Figure 78

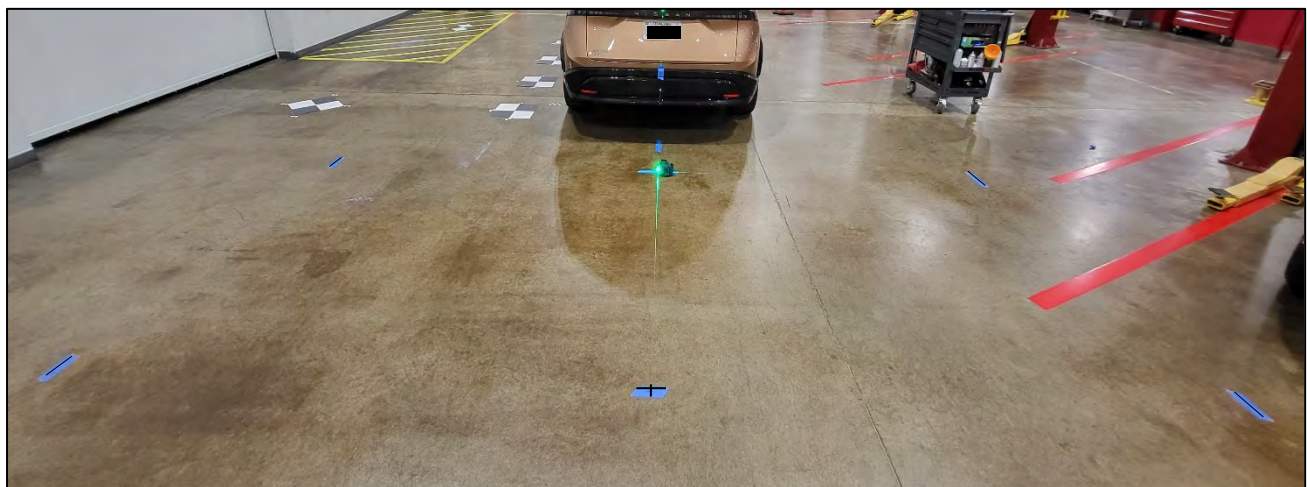

Figure 79

53. Use a chalk line tool to make a line between the 500 mm and 2500 mm marks, as shown in Figure 80 and Figure 81.

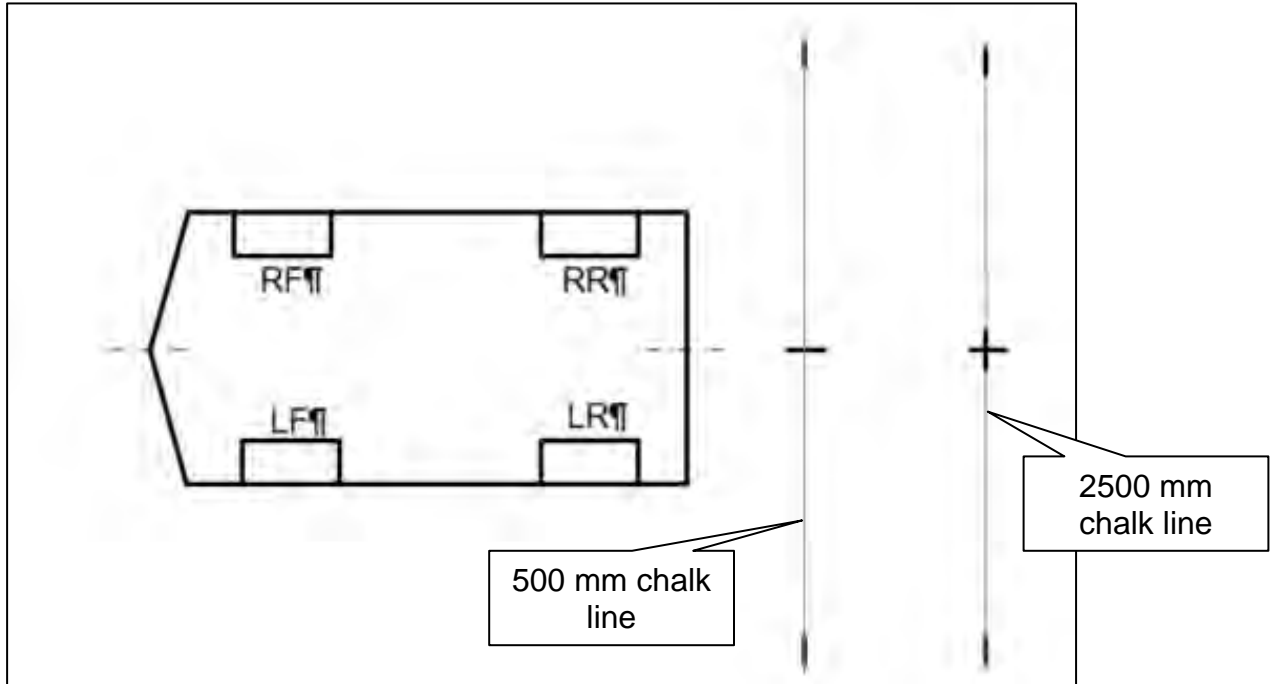

Figure 80

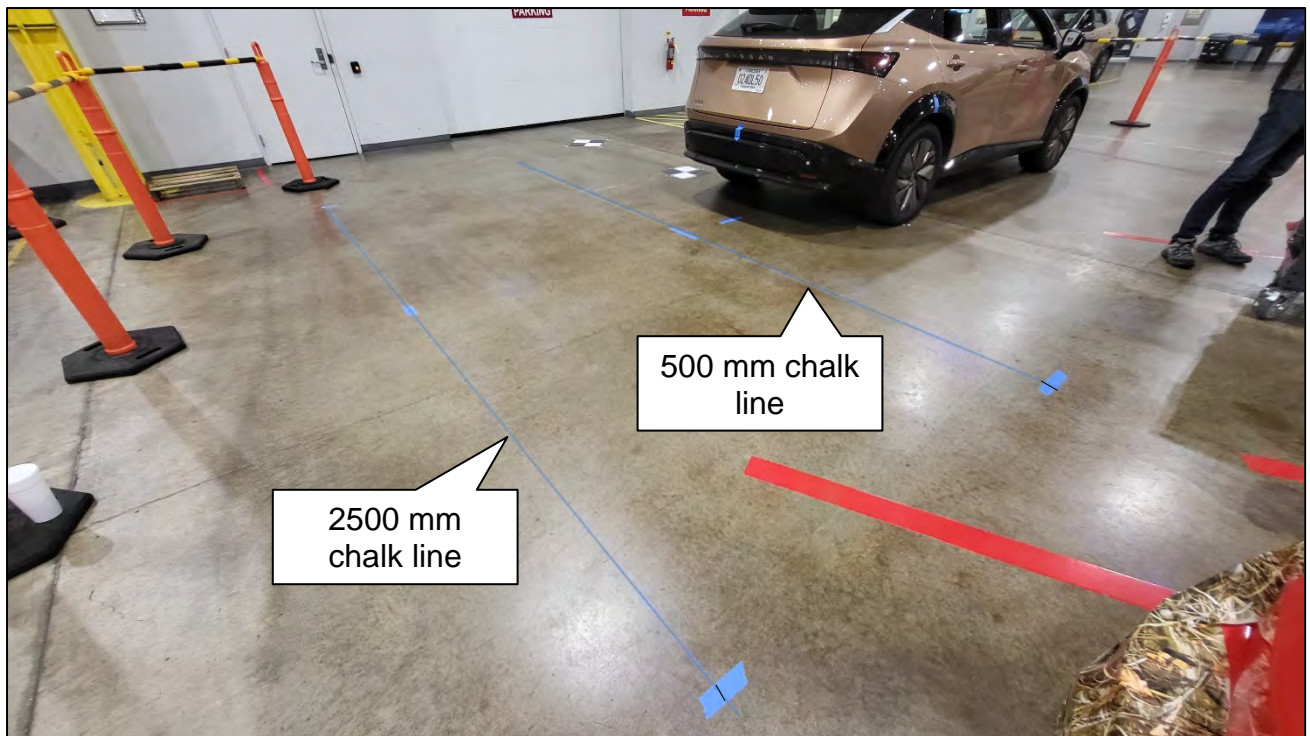

Figure 81

54. Place the laser level with both vertical lines activated, and align one laser line with the 500 mm chalk line and align the other laser line to the front and rear center point of the vehicle, as shown in Figure 82.

IMPORTANT: The laser line must be perfectly aligned with the 500 mm chalk line and the front and rear center points.

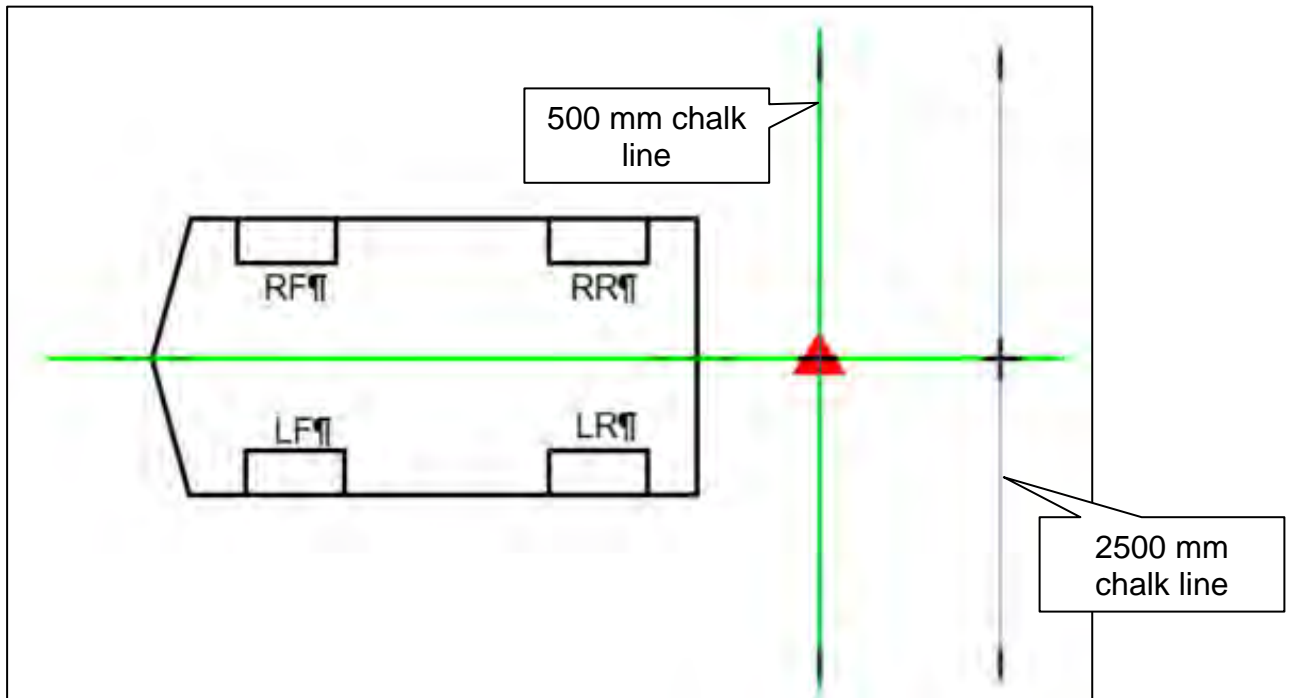

Figure 82

55. Place a cross-mark on the floor below the laser line (Figure 83).

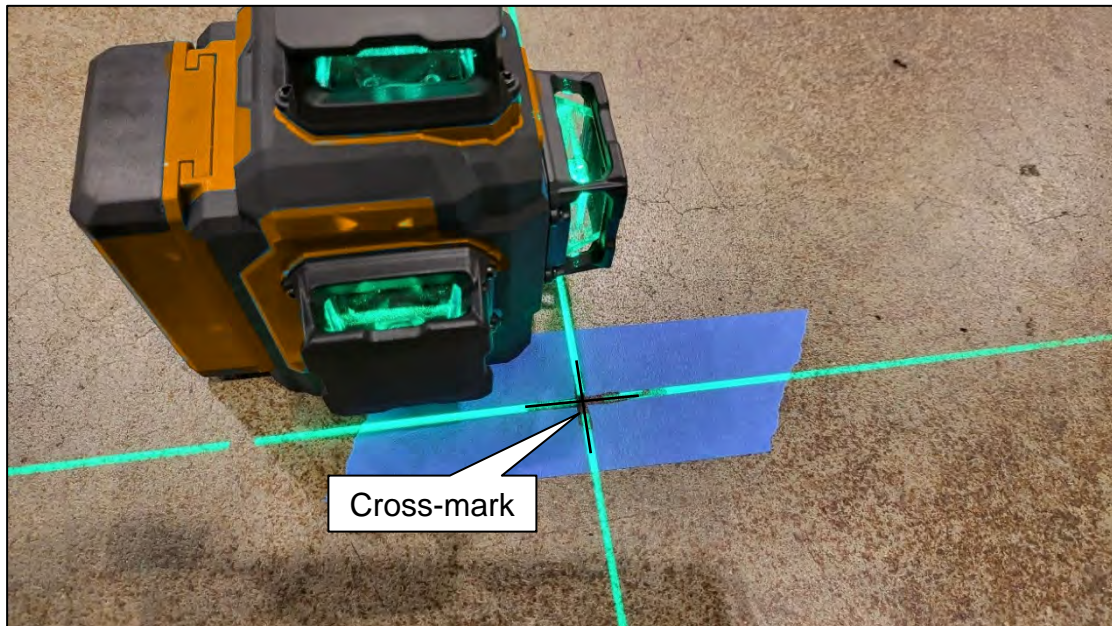

Figure 83

56. Measure and mark 1000 mm increments, as shown in Figure 84 and Figure 85.

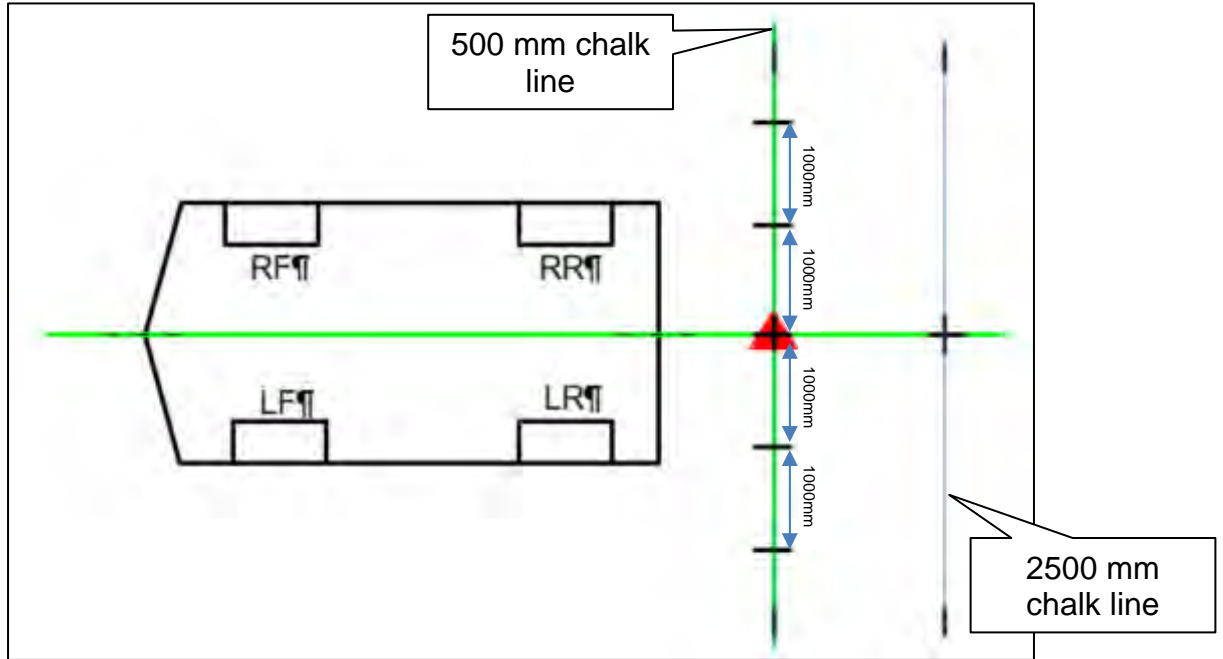

Figure 84

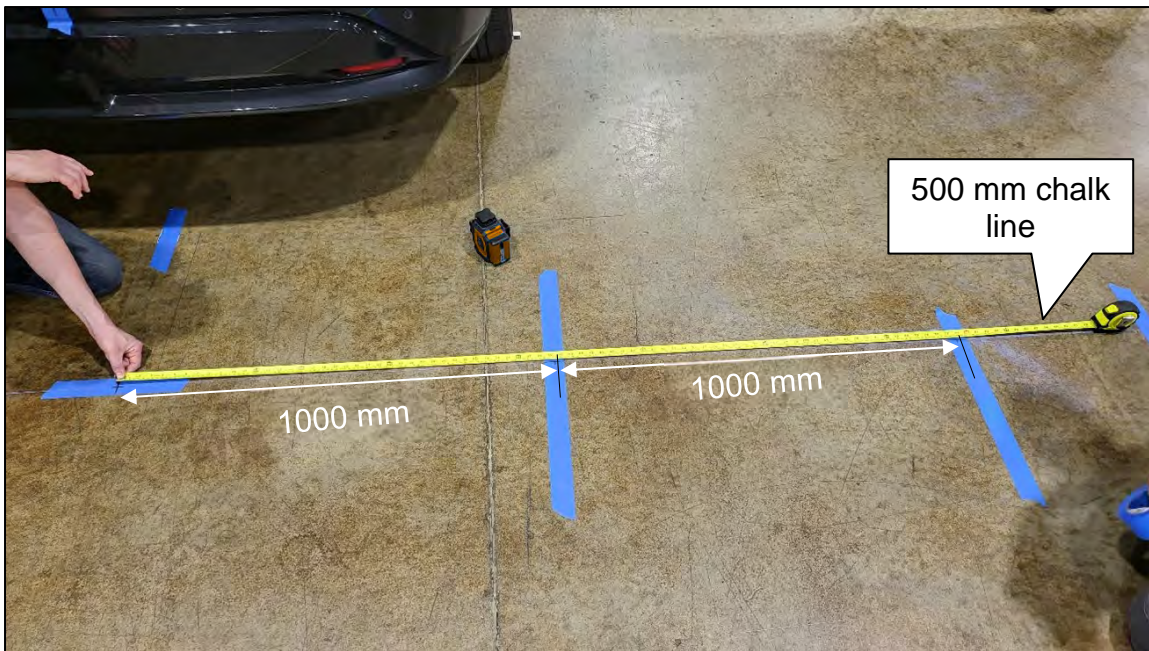

Figure 85

57. Move the laser level to the position shown in Figure 86, and then make a mark on the 2500 mm chalk line, as shown in Figure 86 and Figure 87.

IMPORTANT: The laser line must be perfectly aligned with the 500 mm chalk line.

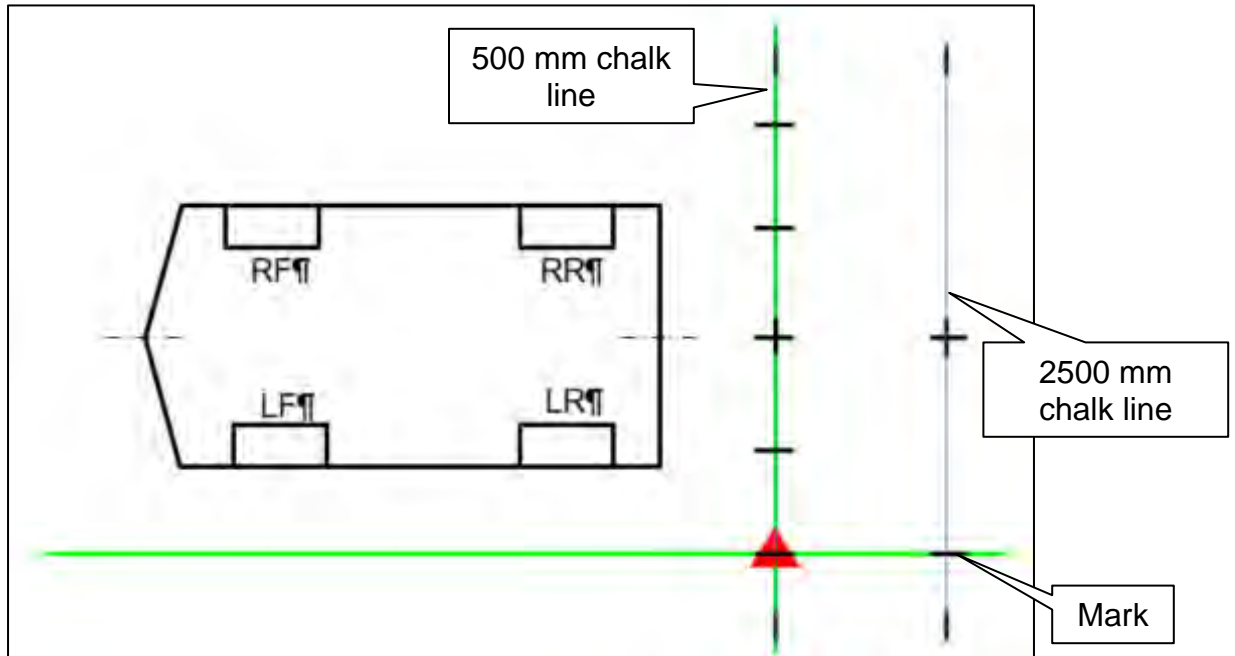

Figure 86

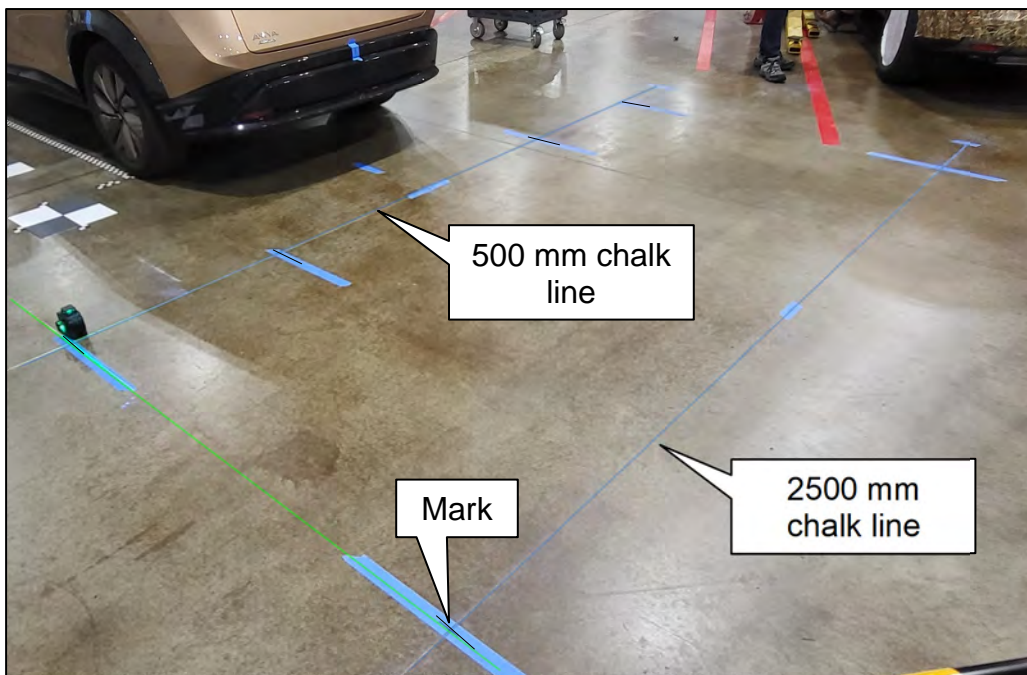

Figure 87

58. Move the laser level to the position shown in Figure 88, and then make a mark on the 2500 mm chalk line, as shown in Figure 88 and Figure 89.

IMPORTANT: The laser line must be perfectly aligned with the 500 mm chalk line.

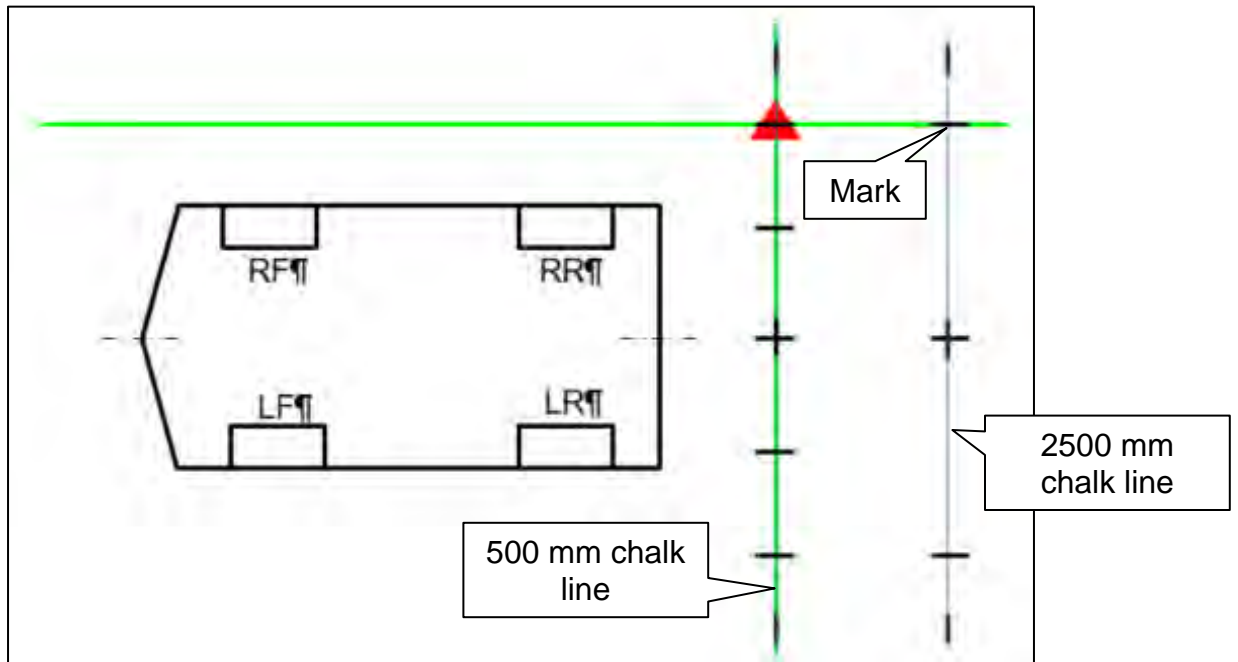

Figure 88

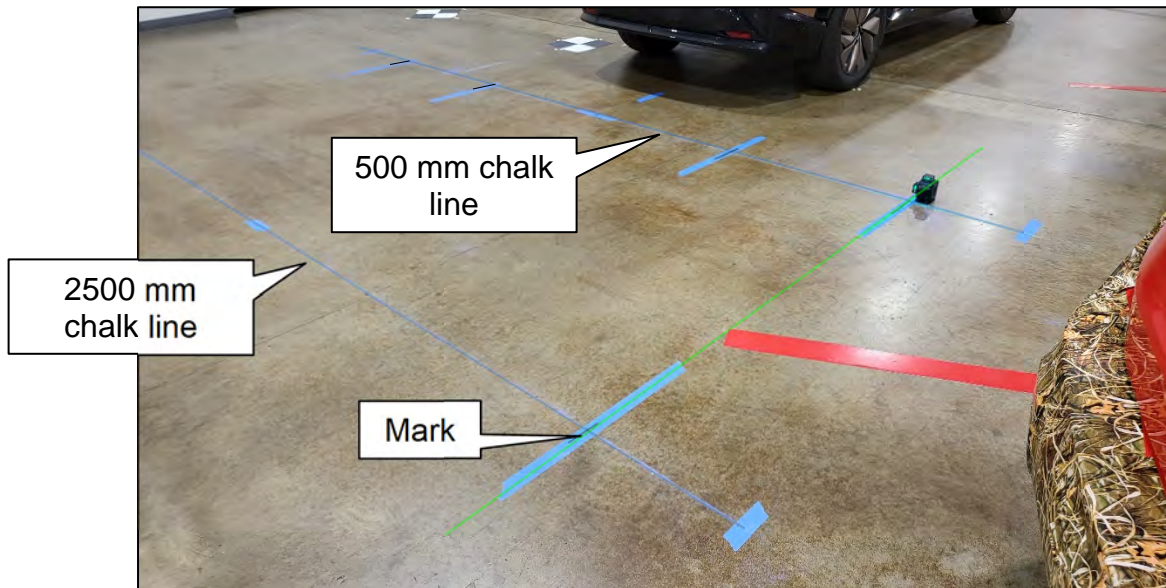

Figure 89

59. Using a carpenter's square, squared to the chalk line, extend each of the seven (7) marks 12 in. from the chalk line.

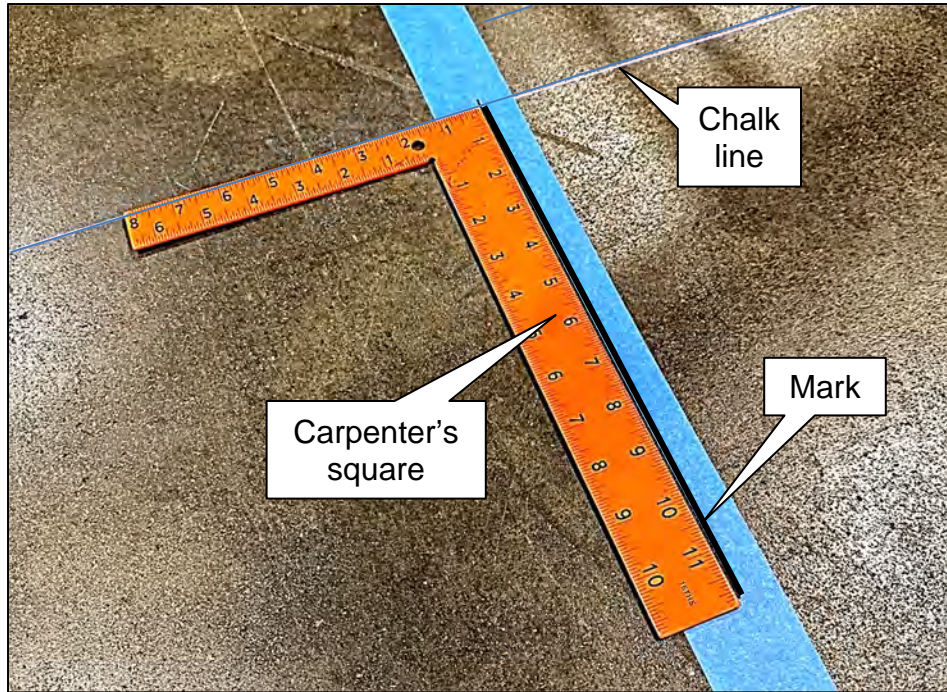

Figure 90

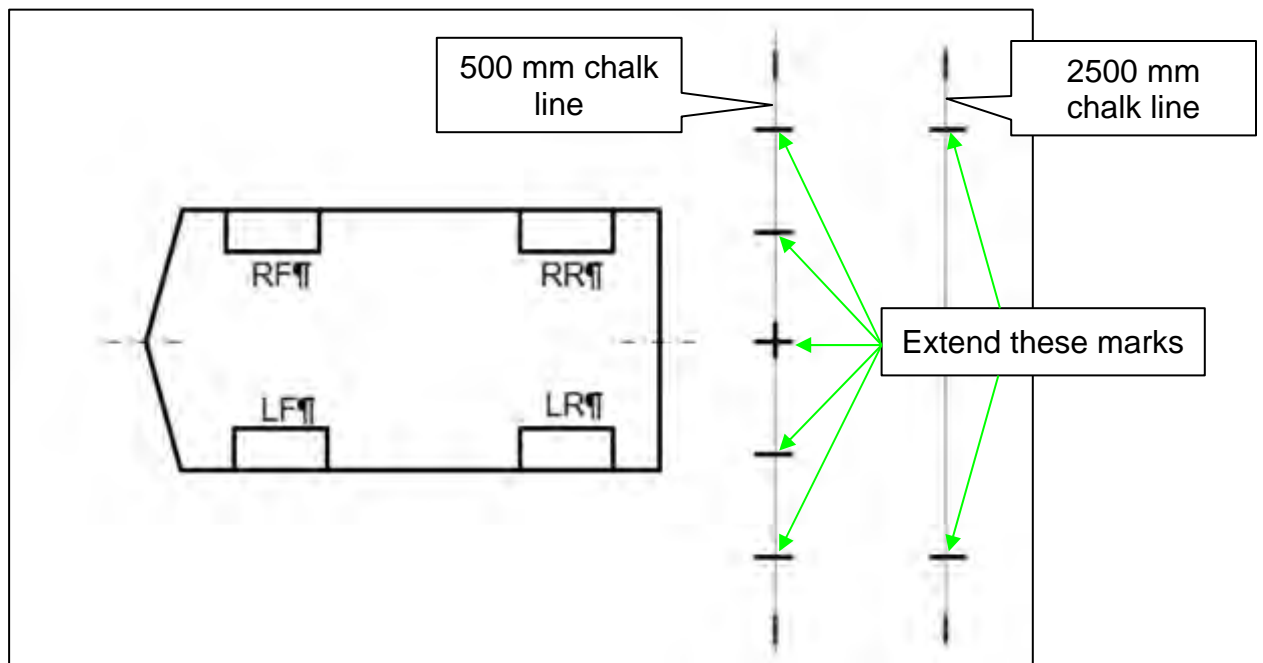

Figure 91

60. Place five (5) targets on the marks along the 500 mm chalk line.

IMPORTANT: Orient and align the targets, as shown in Figure 92, Figure 93, and Figure 94. The targets must be aligned with the 500 mm chalk line and the marks made in step 59 on page 46.

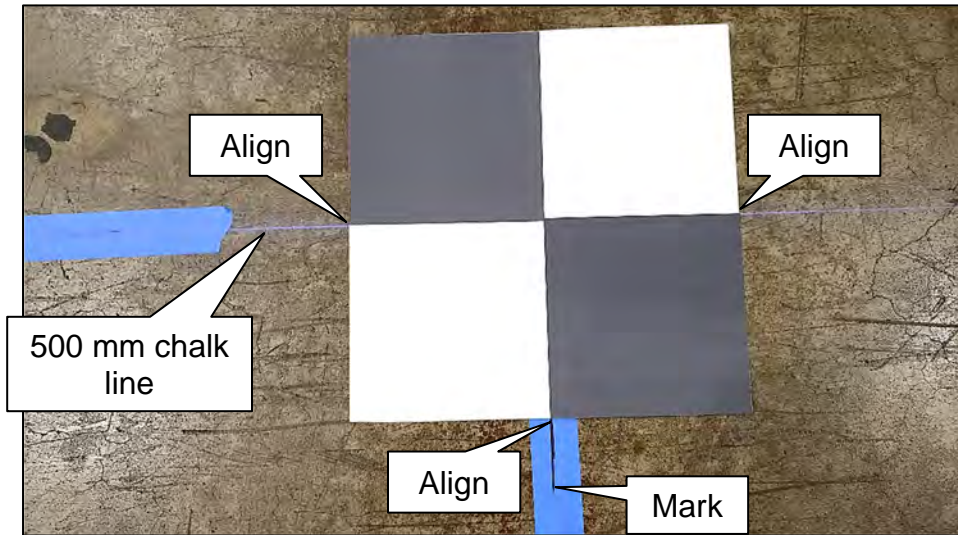

Figure 92

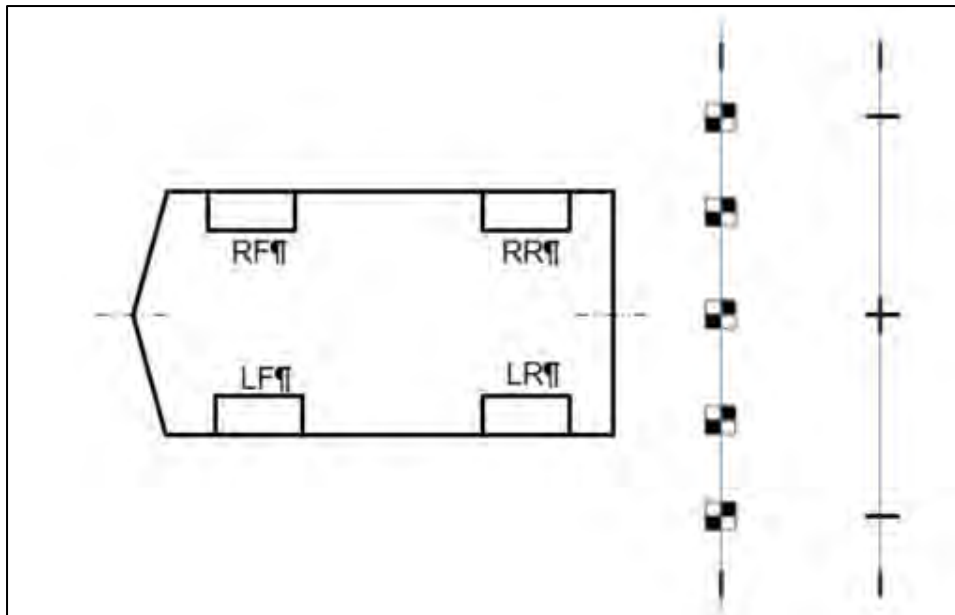

Figure 93

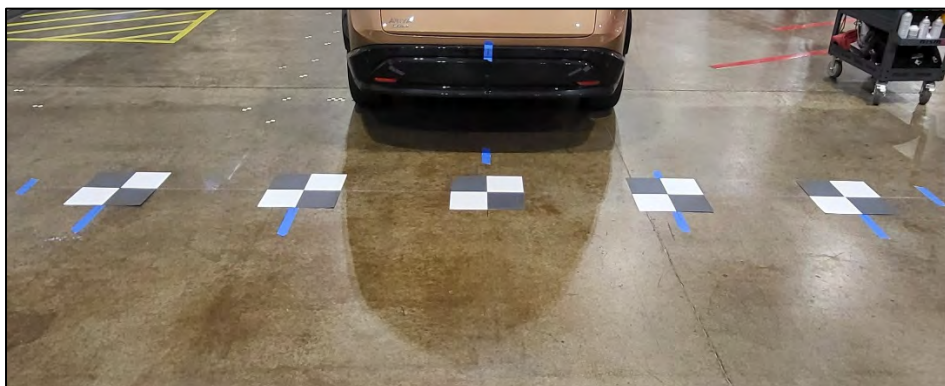

Figure 94

61. Place one (1) target on the driver (LH) side mark on the 2500 mm chalk line.

IMPORTANT: Orient and align the target, as shown in Figure 95, Figure 96, and Figure 97. The target must be aligned with the 2500 mm chalk line and the marks made in step 59 on page 46.

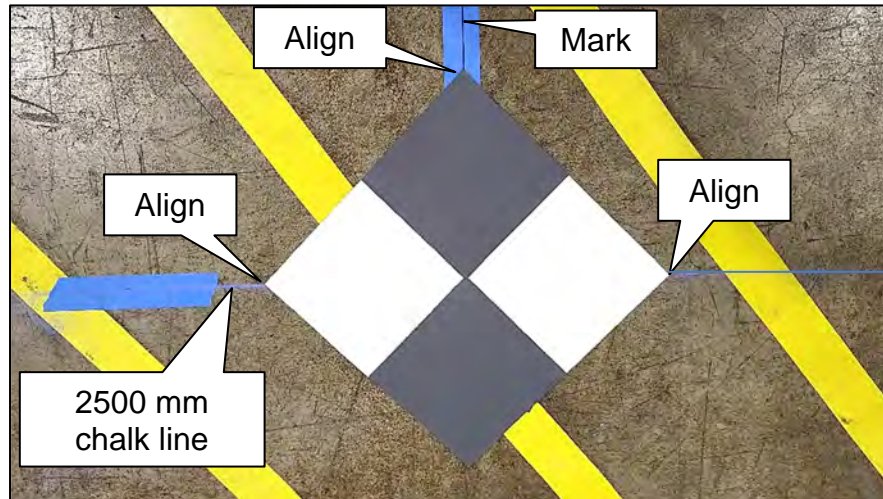

Figure 95

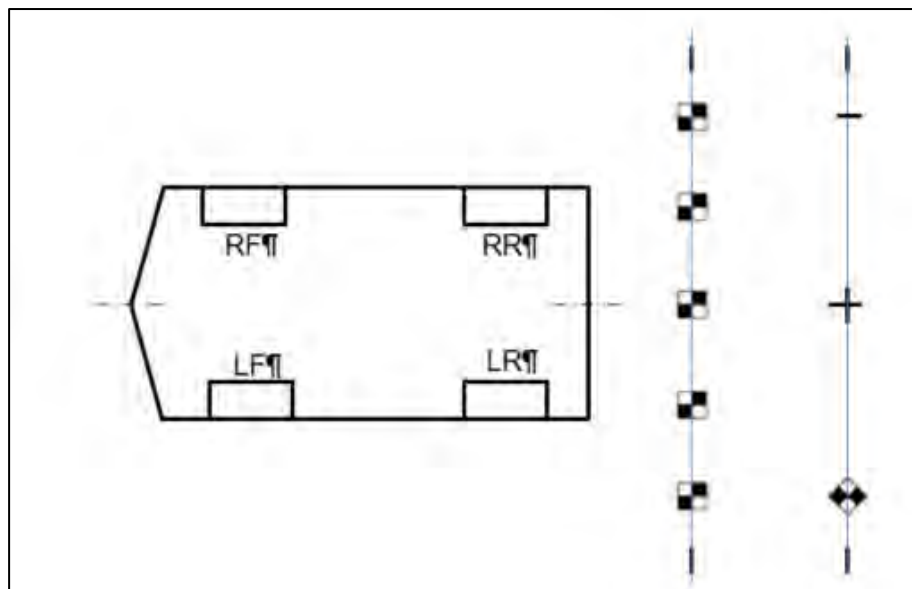

Figure 96



Figure 97

62. Place one (1) target on the passenger (RH) side mark on the 2500 mm chalk line.

IMPORTANT: Orient and align the target, as shown in Figure 98, Figure 99, and Figure 100. The target must be aligned with the 2500 mm chalk line and the marks made in step 59 on page 46.

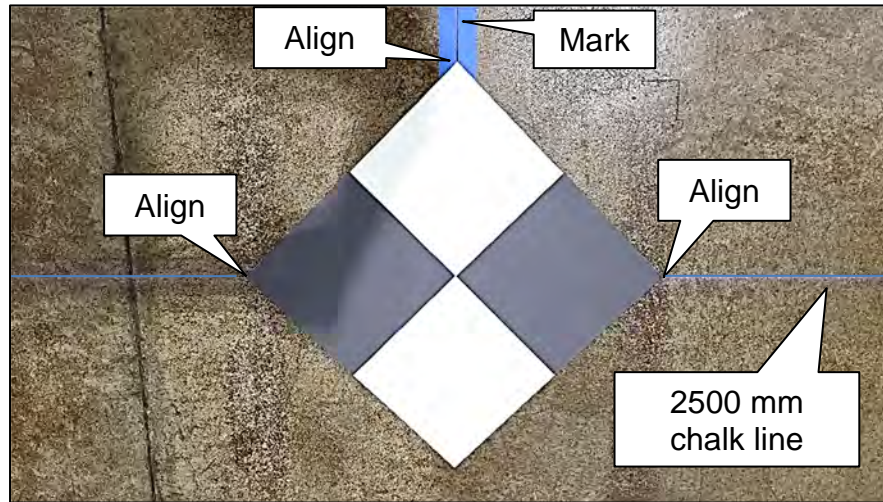

Figure 98

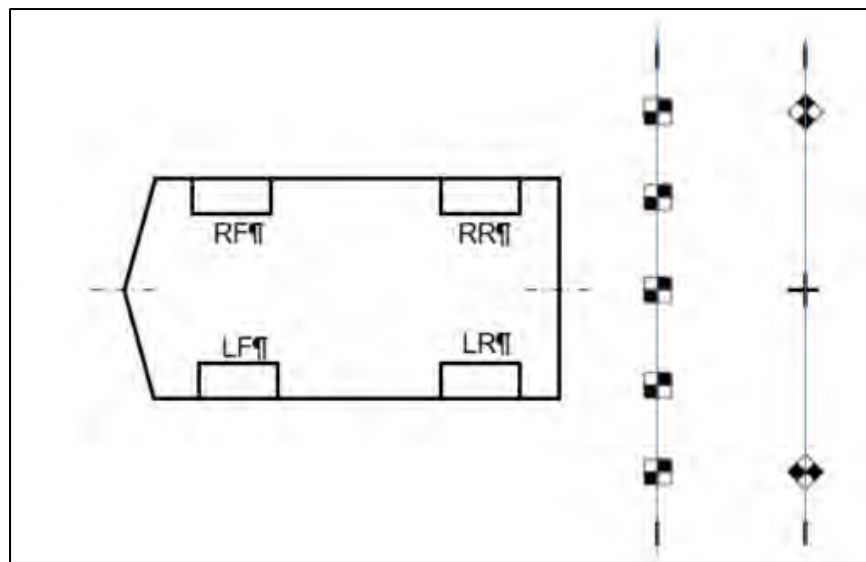

Figure 99

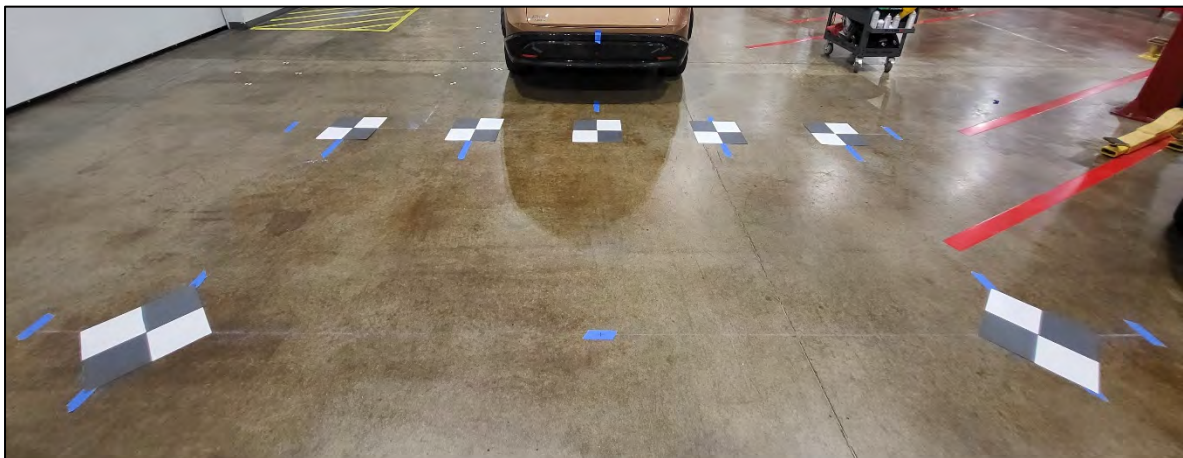

Figure 100

63. If the front camera was replaced, repeat steps 48 - 62 starting on page 36, to place the calibration targets for the front camera.
64. Measure 200 mm and 283 mm from the center point of the driver (LH) side rear wheel, and then make a mark at each measurement, as shown in Figure 101.

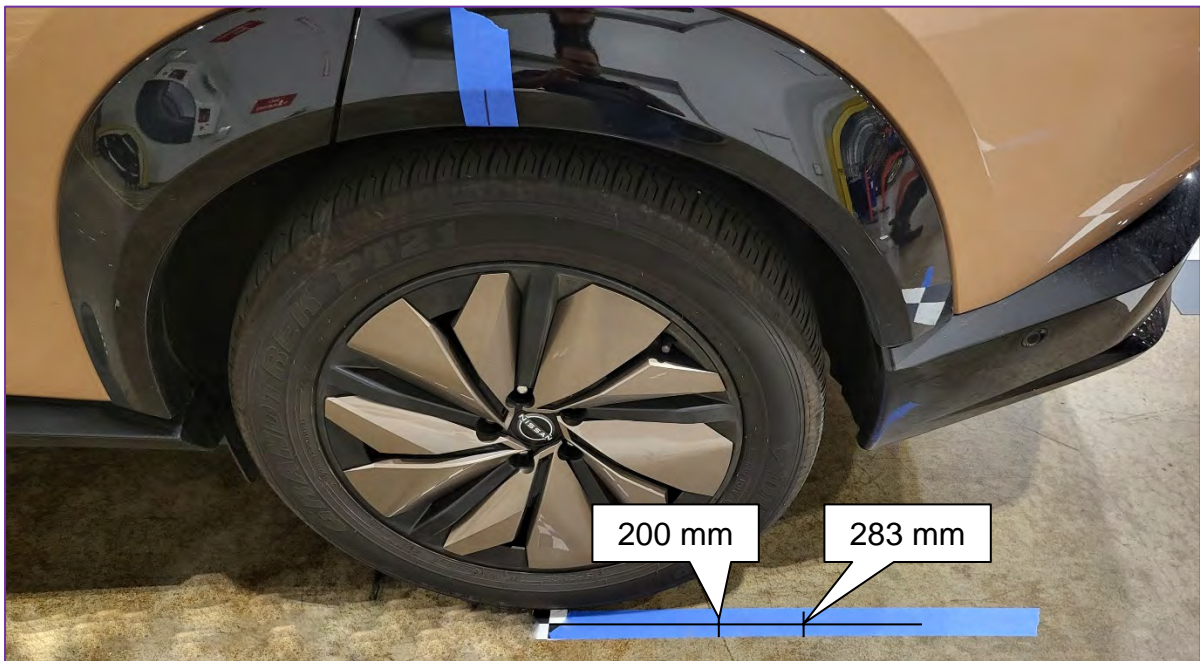

Figure 101

65. Measure 200 mm and 283 mm from the center point of the passenger (RH) side rear wheel, and then make a mark at each measurement, as shown in Figure 102.

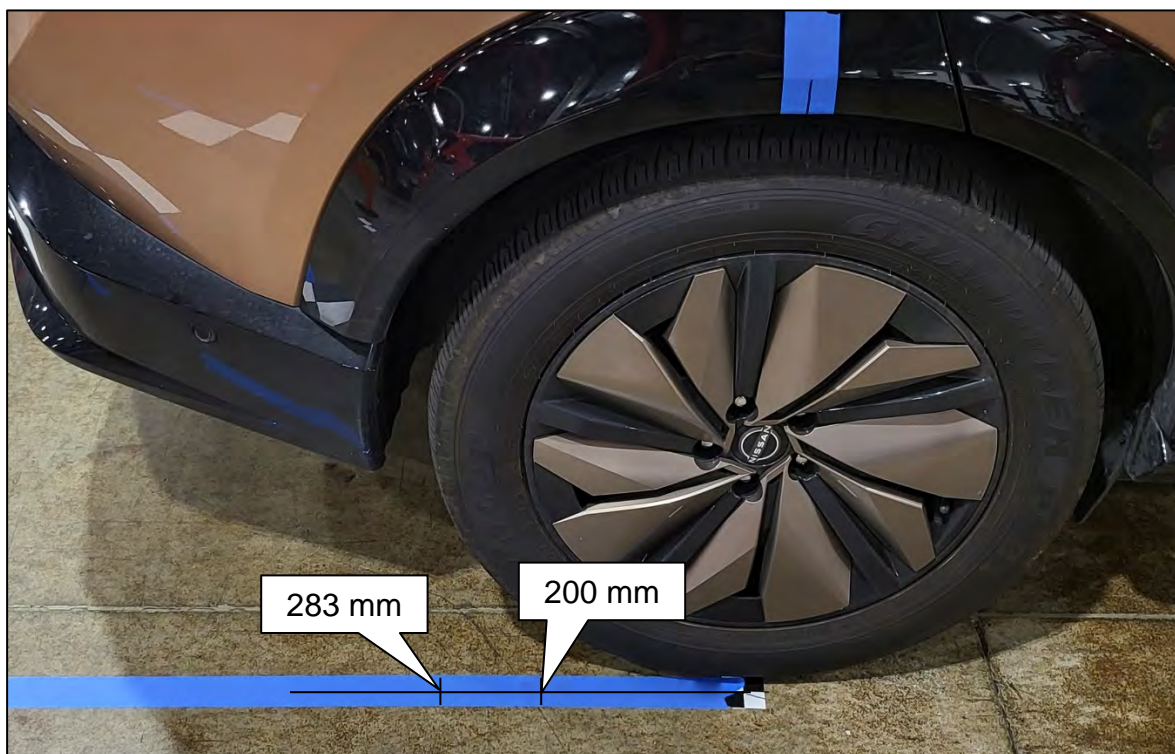

Figure 102

Rear Camera Calibration Measurements

IMPORTANT: All measurements must be in millimeters (mm). Refer to the illustrations in Figure 107 on page 54 to ensure the correct measurement is documented in the correct order and for each calibration target.

66. Measure the distance between the center point of the driver (LH) side rear wheel to the center of the calibration target T1, and then document that distance as L1 in Figure 107 on page 54.

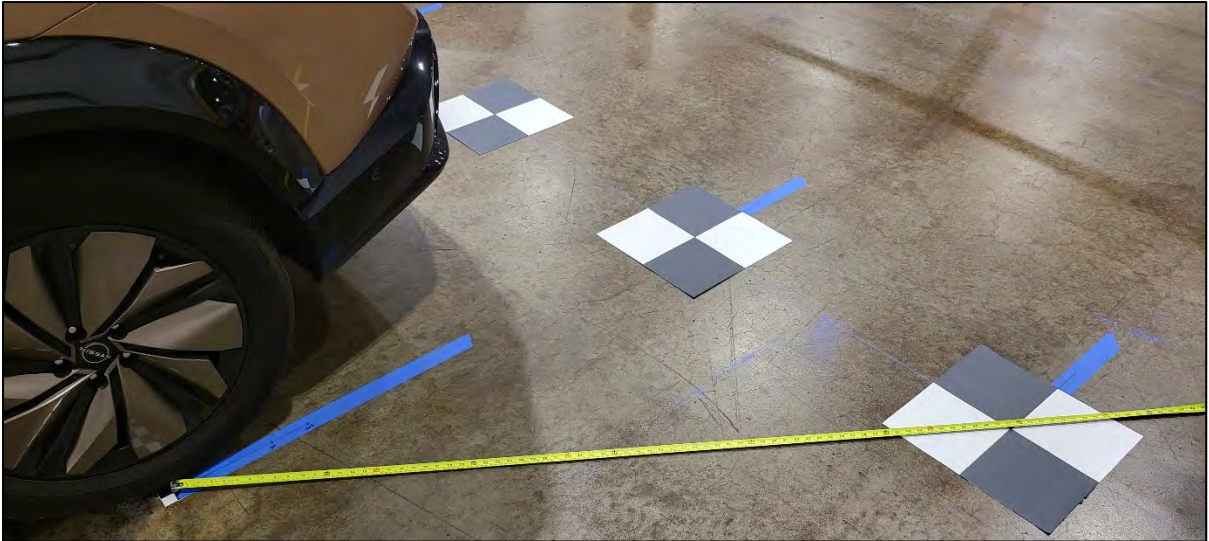

Figure 103

67. Measure the distance between the center point of the driver (LH) side rear wheel to the center of the calibration target T6, and then document that distance as L2 in Figure 107 on page 54.

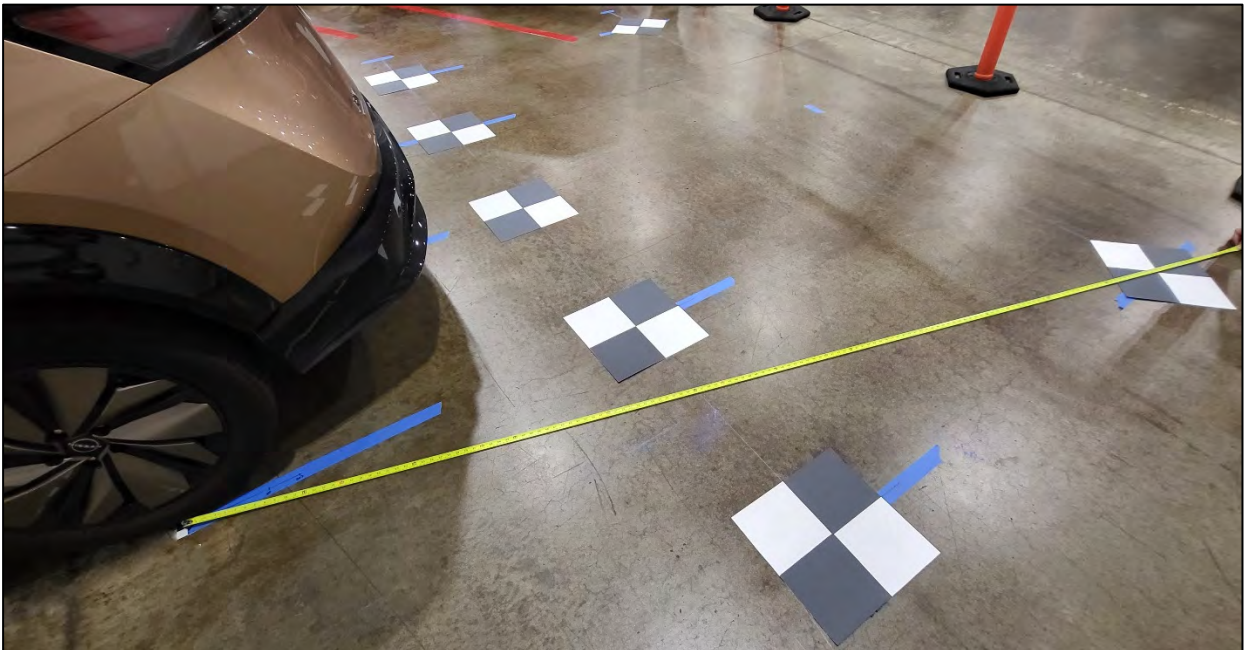

Figure 104

68. Measure the distance between the 283 mm mark of the driver (LH) side rear wheel to the most rearward point of the calibration target T7, and then document that distance as L3 in Figure 107 on page 54.

IMPORTANT: Do not measure to the center point of the target. Measure to the point shown in Figure 105.

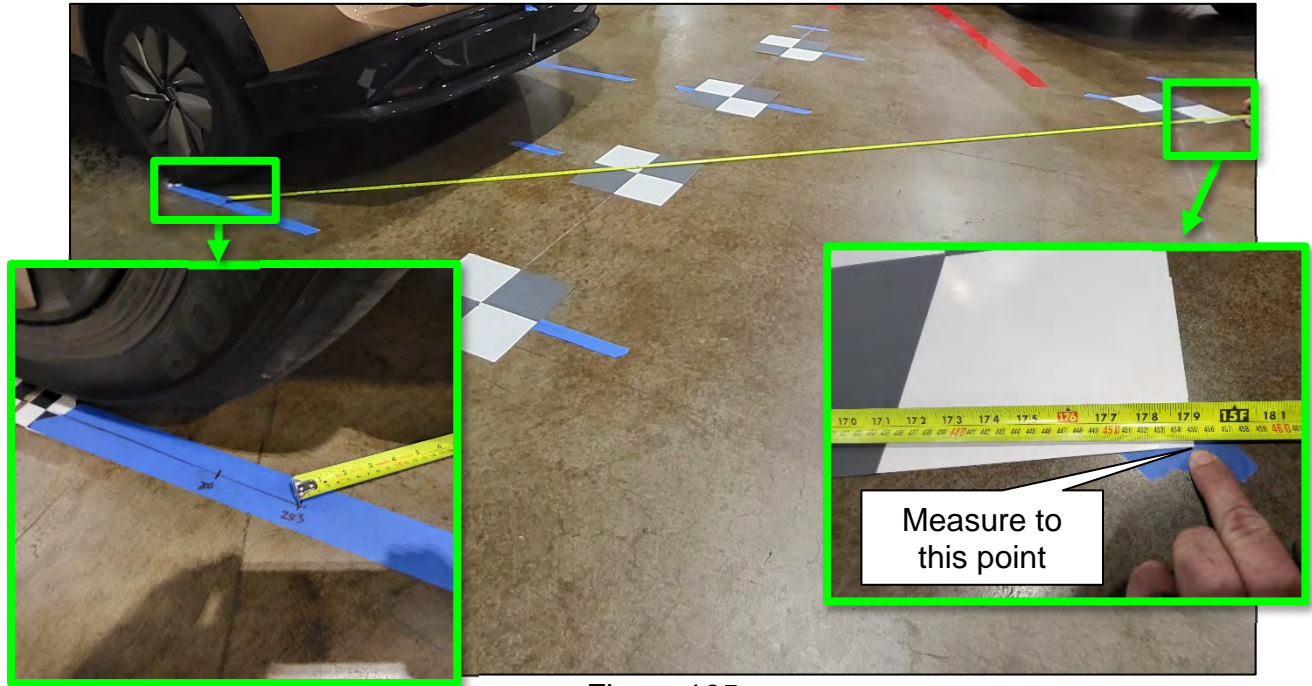

Figure 105

69. Measure the distance between the 200 mm mark of the driver (LH) side rear wheel to the most rearward point of the calibration target T5, and then document that distance as L4 in Figure 107 on page 54.

IMPORTANT: Do not measure to the center point of the target. Measure to the point shown in Figure 106.

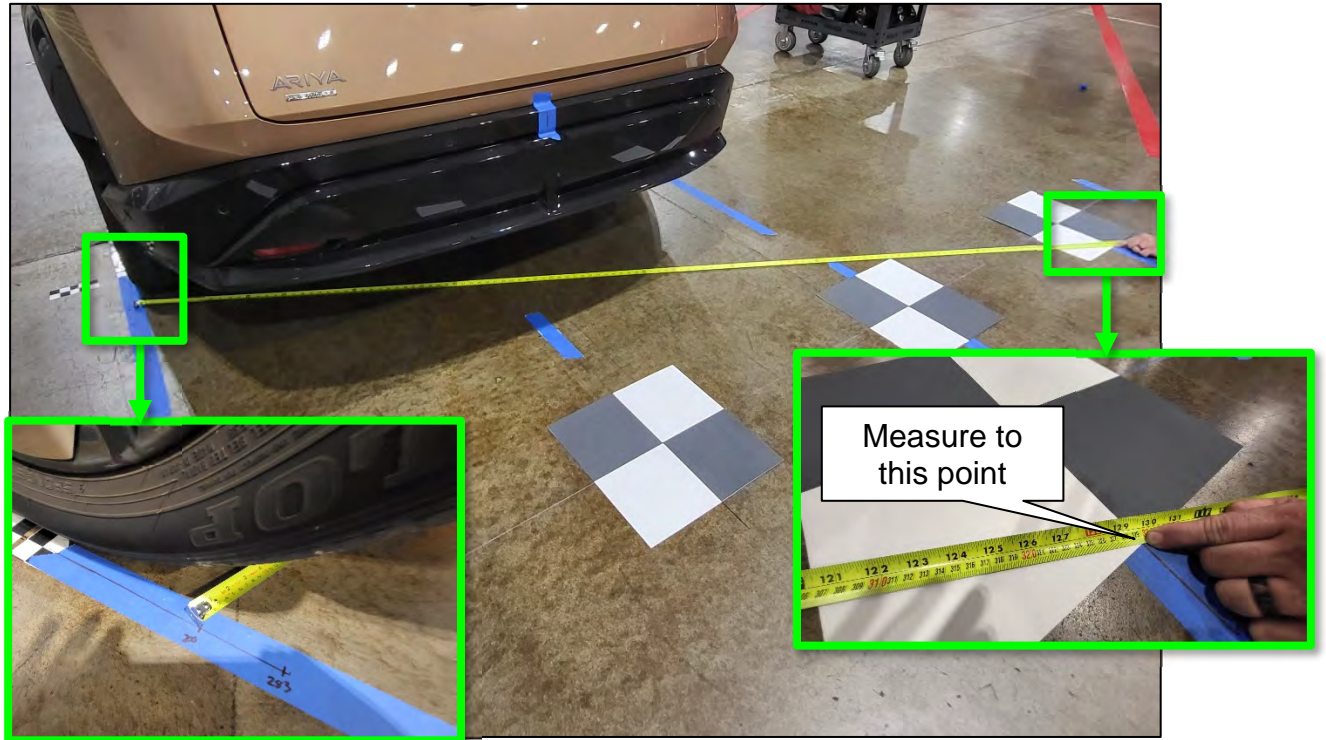

Figure 106

70. Perform steps 66 - 69 starting on page 51 for the passenger (RH) side rear wheel measurements L5-L8, and then document the distances in Figure 107.

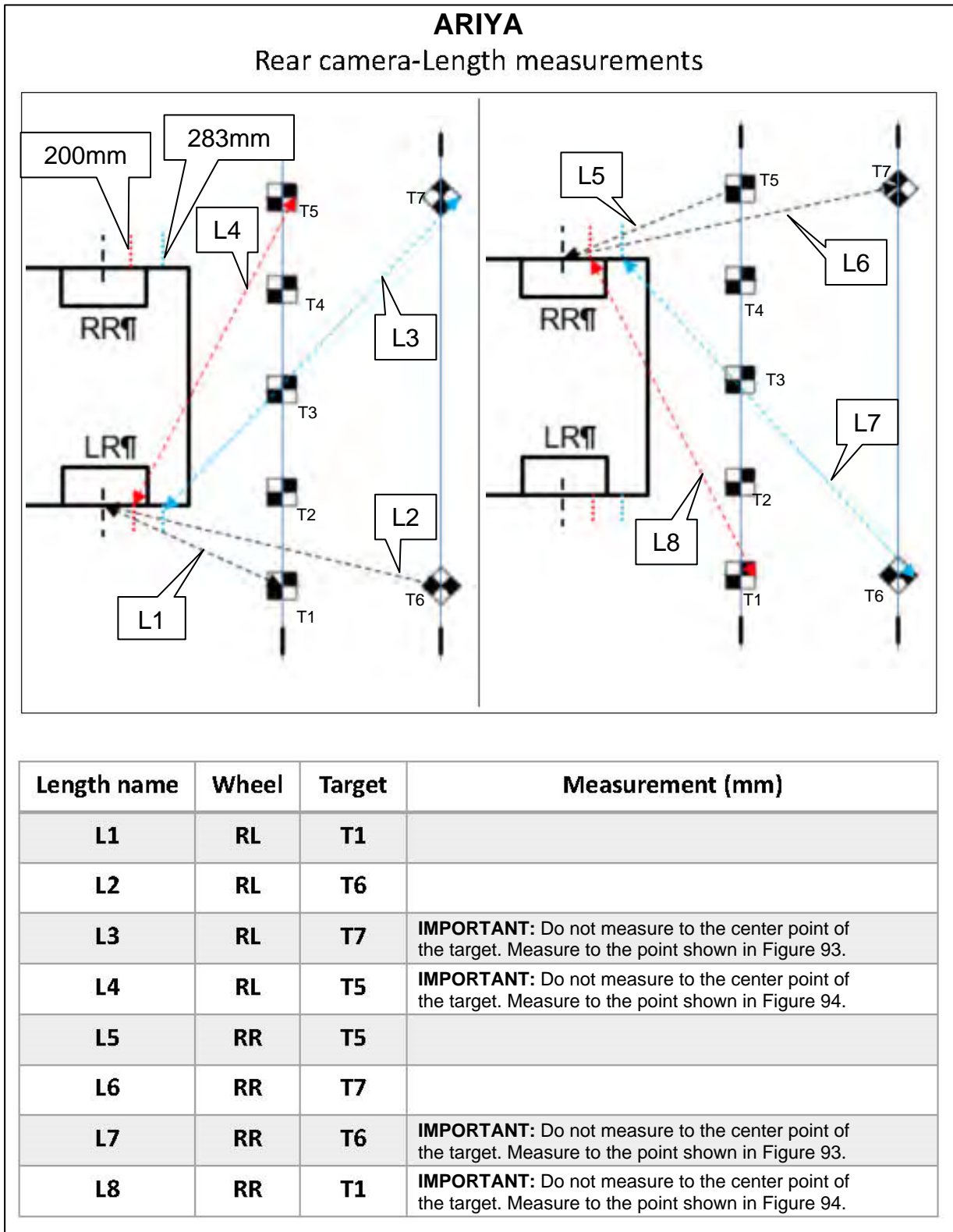

Figure 107

71. Place the laser level on a clean cloth, and then on the roof of the vehicle.

IMPORTANT:

- Place the laser level in the middle of the vehicle's roof.
- The laser level must be still (no fans should be blowing).



Figure 108



Figure 109

IMPORTANT: For steps 72 and 73:

- When holding the carpenter's ruler, ensure the ruler is completely upright and does not bend.
- All measurements must be in millimeters (mm).
- Refer to the illustrations in Figure 112 on page 56 to ensure the correct measurement is documented in the correct order and for each calibration target.

72. Using a folding carpenter's ruler, measure the height from the center of each calibration target, and then record the measurements H1-H7 in the table in Figure 112 on page 56.



Figure 110

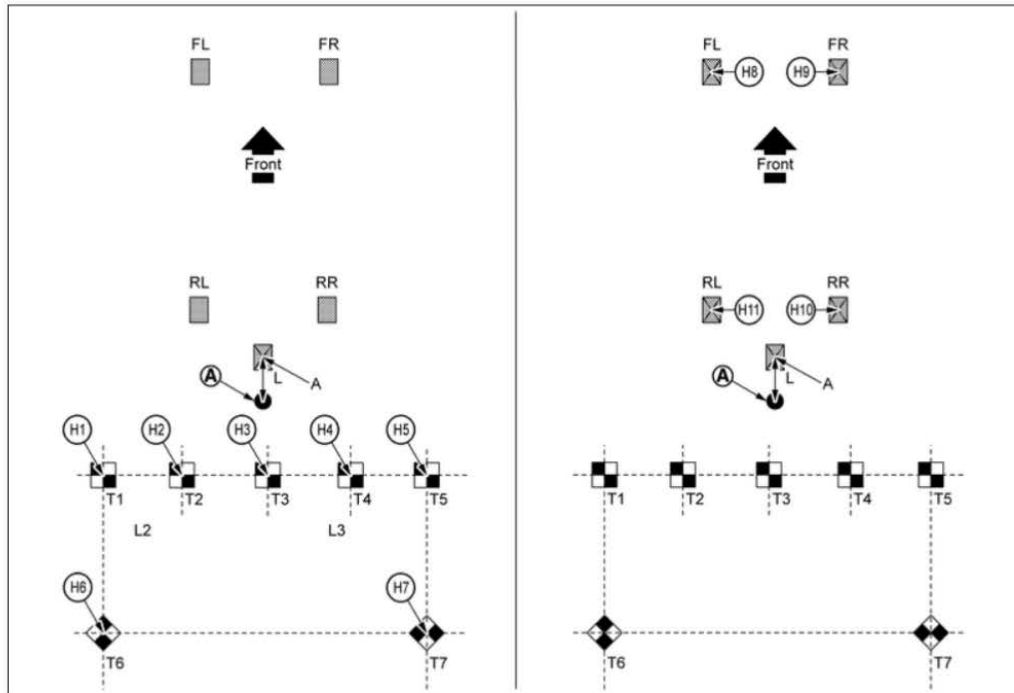

Figure 111

73. Using a folding carpenter's ruler, measure the height from the wheel center point, and then record the measurements H8-H11 in the table in Figure 112 on page 56.

ARIYA

Rear camera-Height measurements



Height name	Wheel	Target	Measurement (mm)
H1	-	T1	
H2	-	T2	
H3	-	T3	
H4	-	T4	
H5	-	T5	
H6	-	T6	
H7	-	T7	
H8	FL	-	
H9	FR	-	
H10	RR	-	
H11	RL	-	

Figure 112

Front Camera Calibration Measurements

IMPORTANT: All measurements must be in millimeters (mm). Refer to the illustrations in Figure 113 and Figure 114 to ensure the correct measurement is documented in the correct order and for each calibration target.

74. Perform steps 64 - 70 starting on page 50 for the front camera.

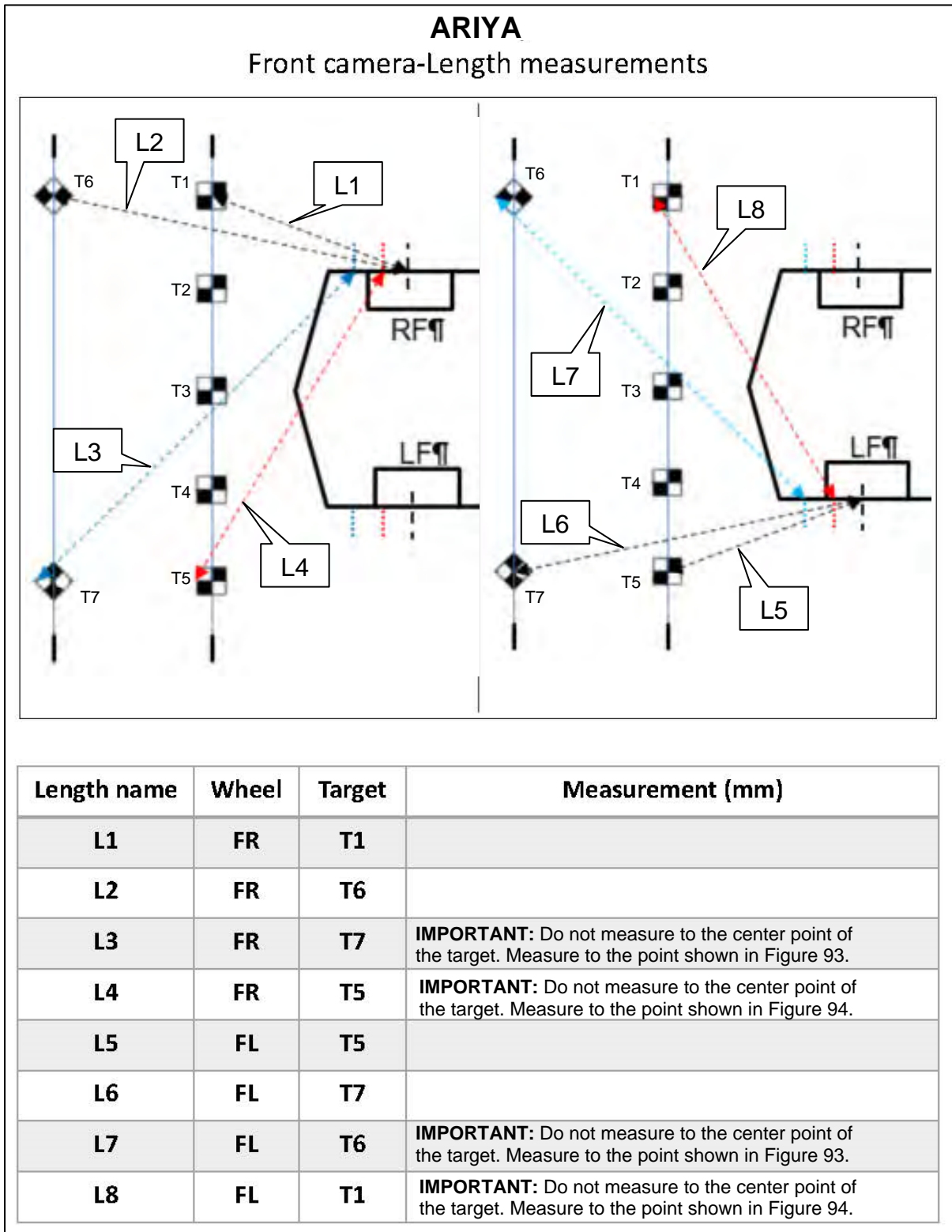

Figure 113

75. Refer to steps 71 - 73 on page 55 to set up the laser level to measure the height of the front camera, and then document the measurements in Figure 114.

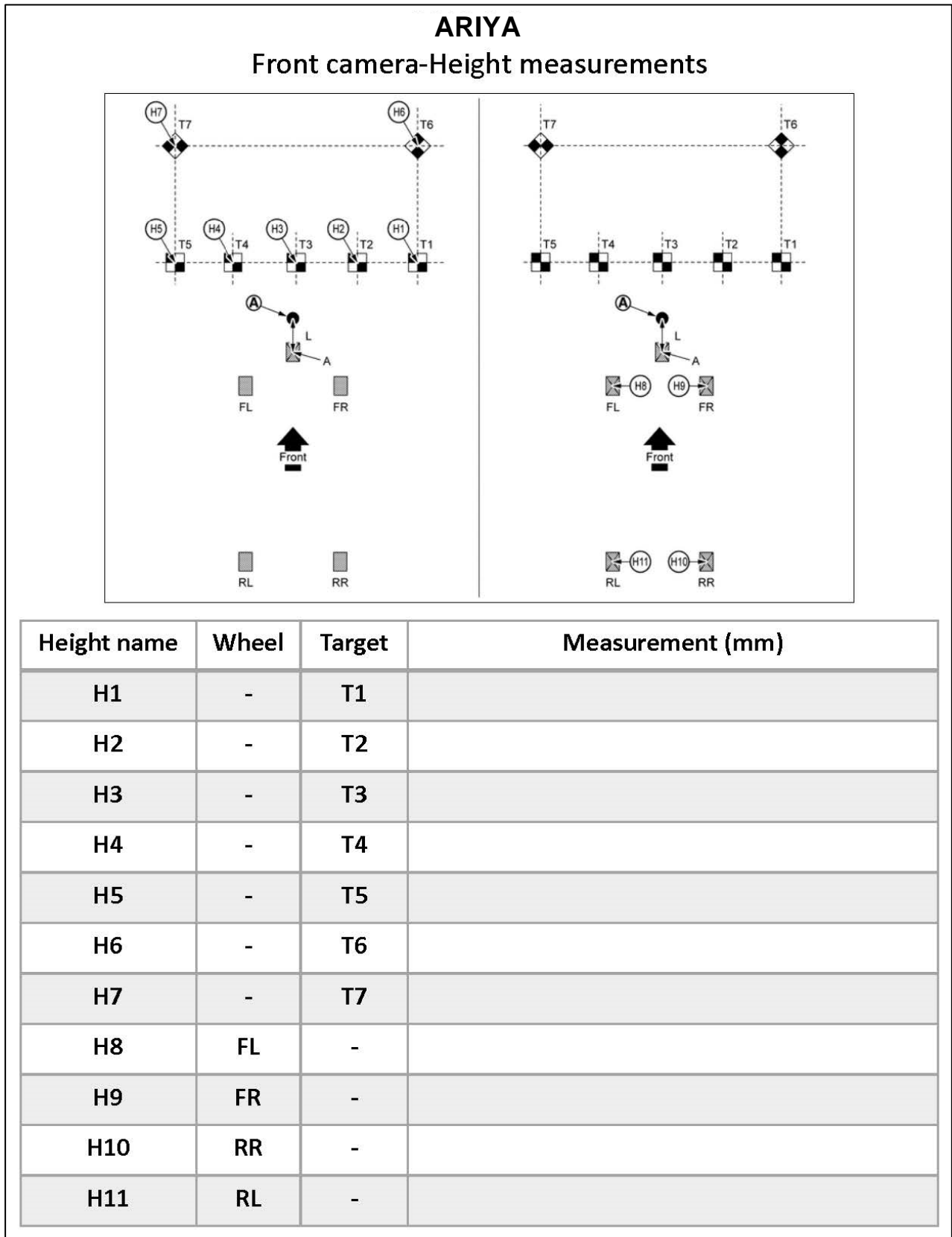

Figure 114

Input the Calibration Target Measurements in CONSULT 4

76. Select **Calibrating camera image**, and then select the green Play icon.

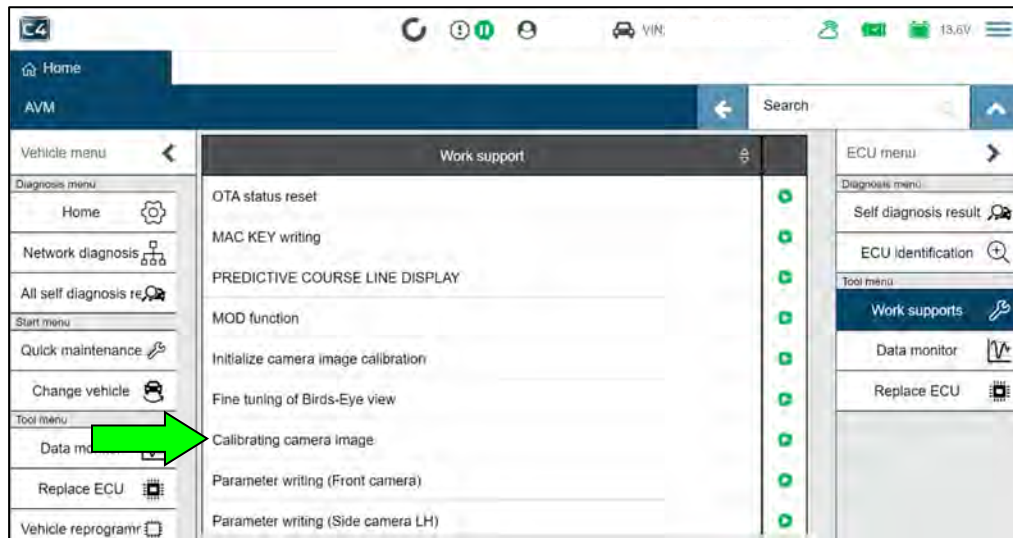

Figure 115

77. Select the camera that needs to be calibrated.

HINT: "No calibration data" displays next to the camera that needs to be calibrated.

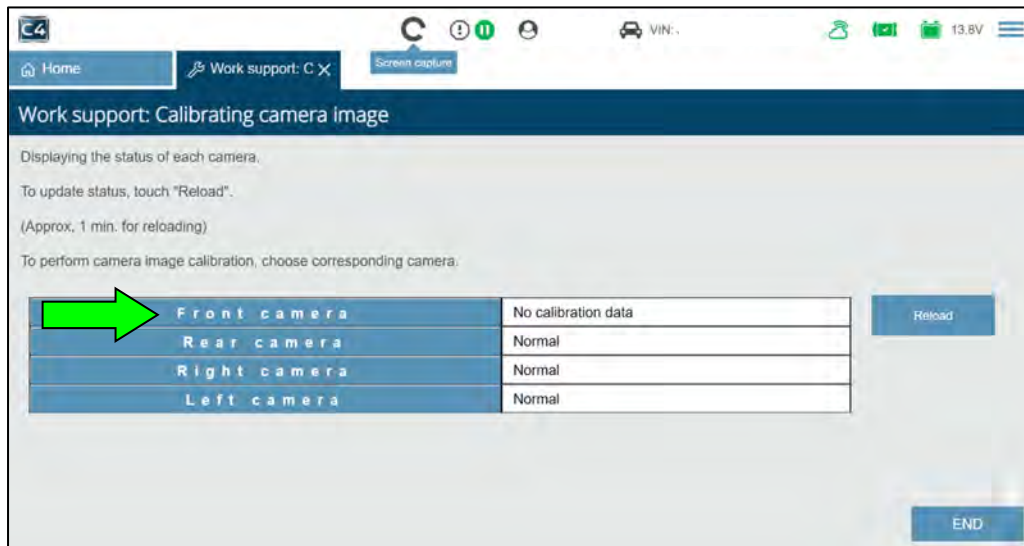

Figure 116

78. Select **Next**.

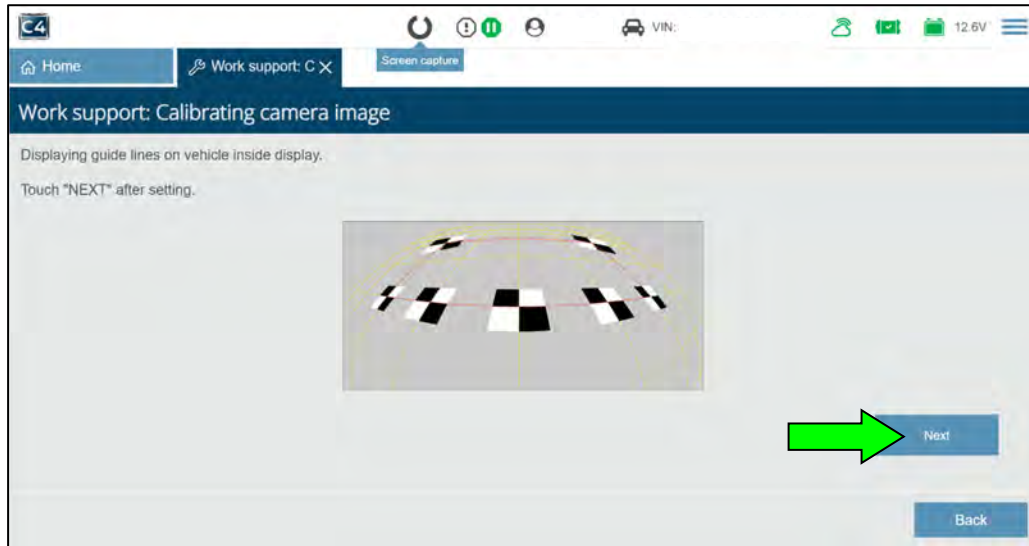

Figure 117

IMPORTANT: Steps 79 - 89 must be done at once. Do not stop in the middle of performing these steps as the CONSULT 4 will time out and all progress will be lost.

79. Select **1**.



Figure 118

80. Move the center of the red crosshair to the center of the calibration target.

HINT: The TENTIMESUP, TENTIMESDOWN, TENTIMESRIGHT, and TENTIMESLEFT boxes will make large adjustments. The arrows will make small adjustments.

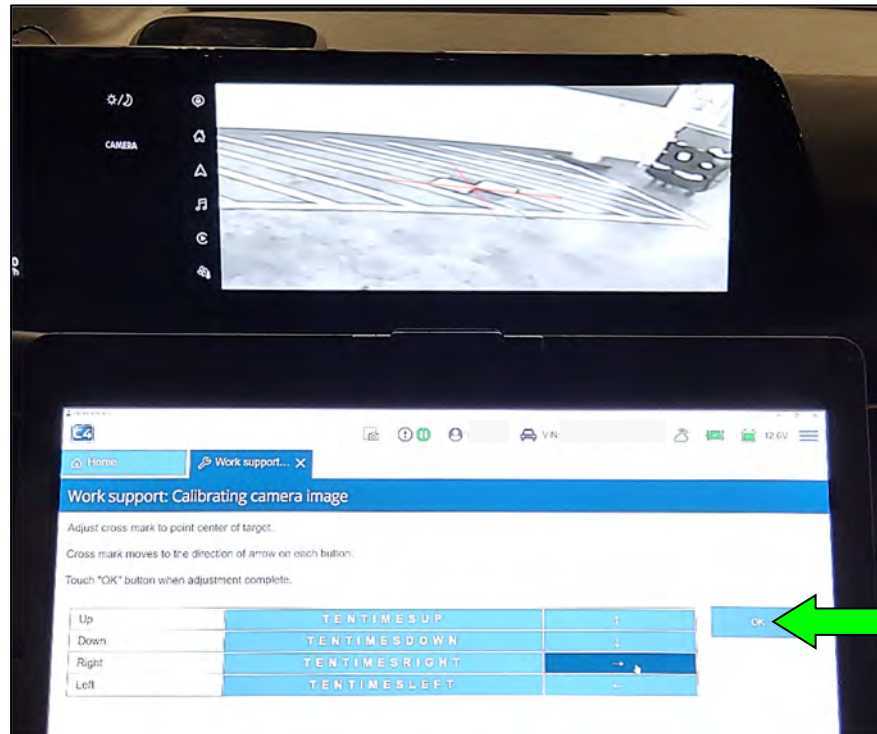

Figure 119

81. When the center of the red crosshair is in the center of the calibration target, select **OK** (Figure 119).

82. Repeat steps 79 - 81 starting on page 60, for all seven (7) targets, and then select **mm**.

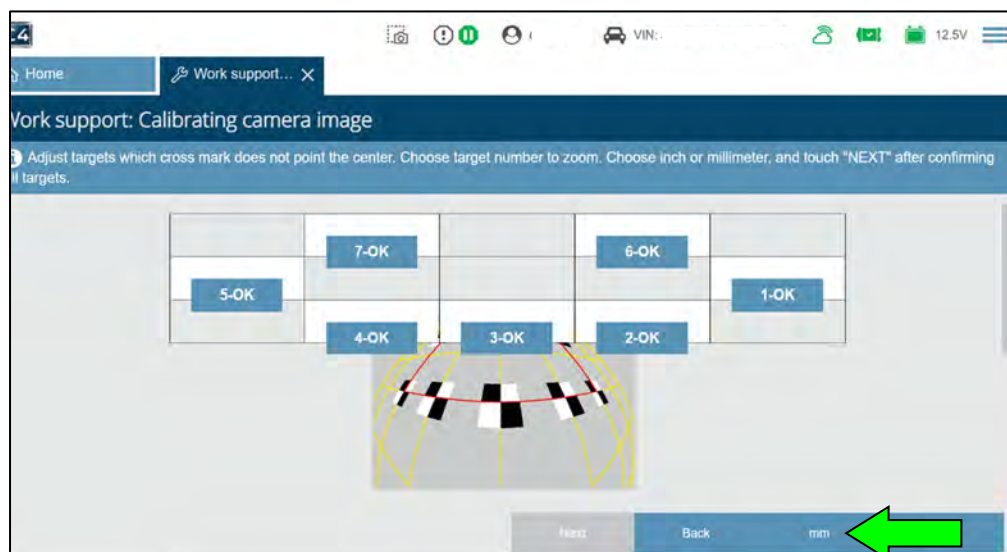

Figure 120

83. Select **Next**.

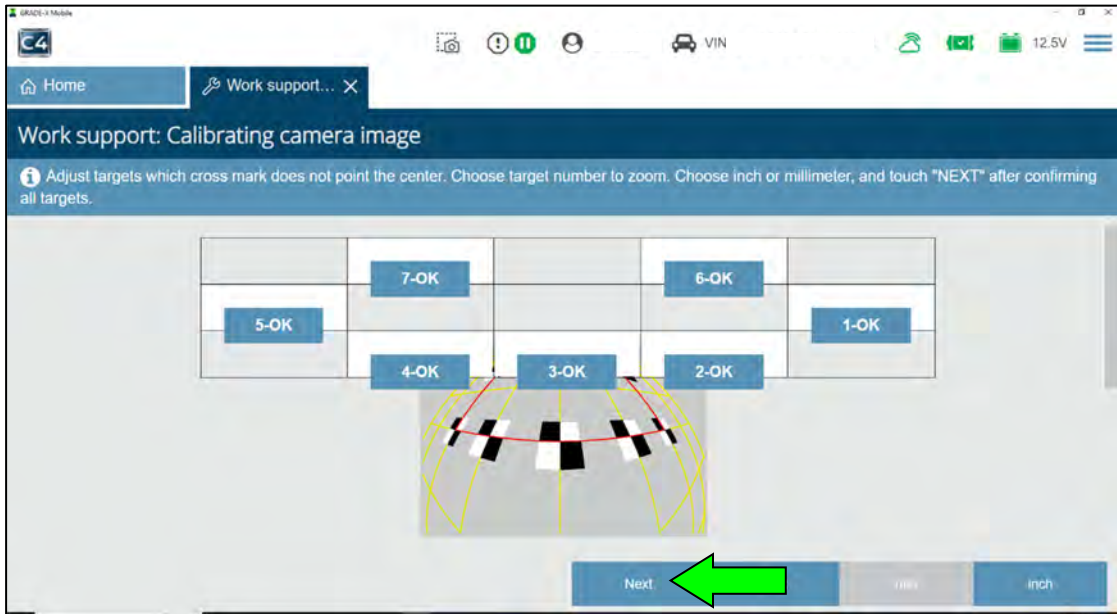

Figure 121

84. Input the length measurements L1-L4 documented for the camera being calibrated, and then select **Next**.

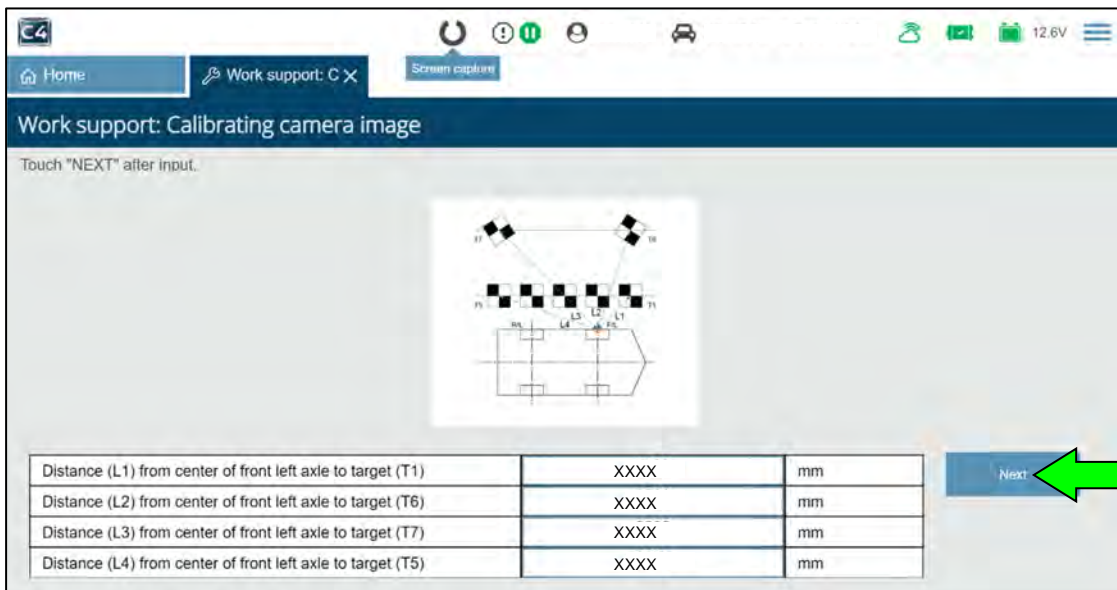

Figure 122

85. Input the length measurements L5-L8 documented for the camera being calibrated, and then select **Next**.

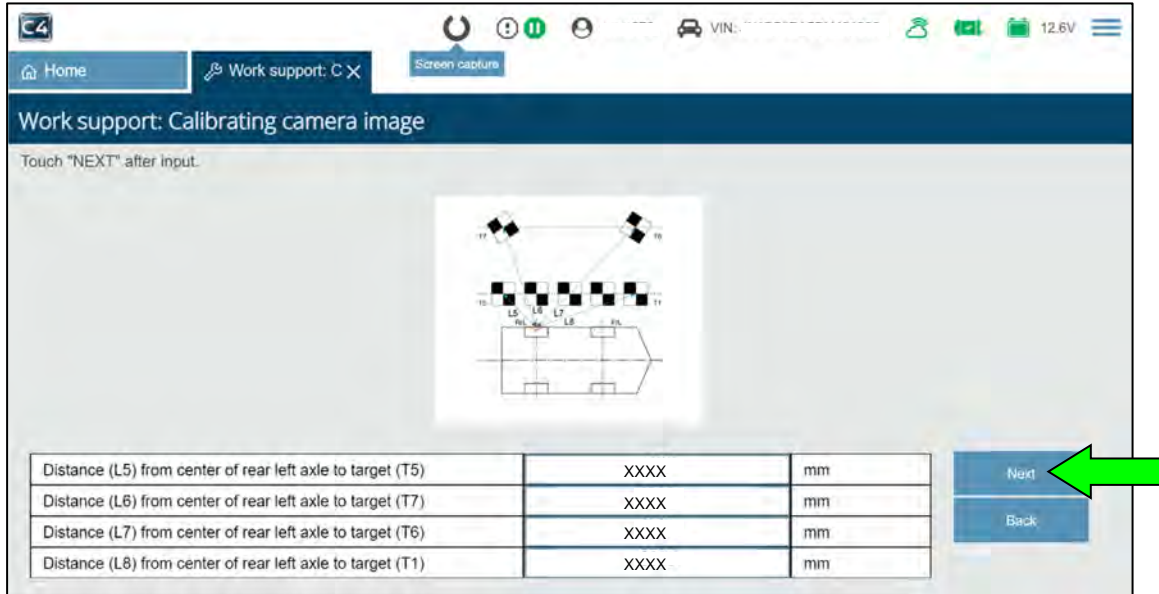

Figure 123

86. Input the height measurements H1-H4 documented for the camera being calibrated, and then select **Next**.

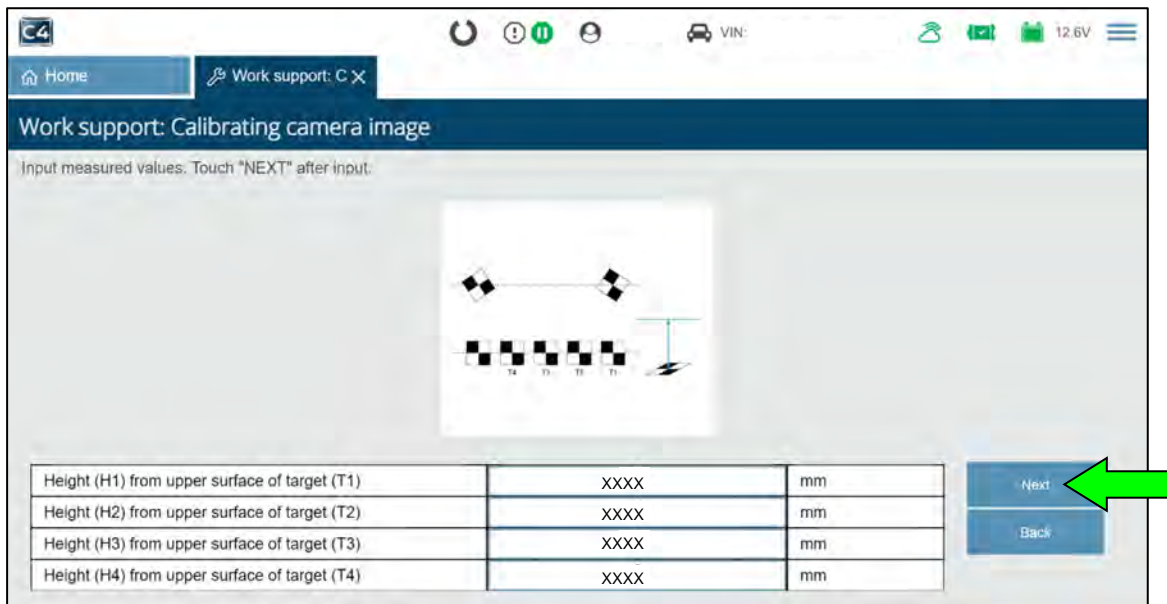

Figure 124

87. Input the height measurements H5-H7 documented for the camera being calibrated, and then select **Next**.

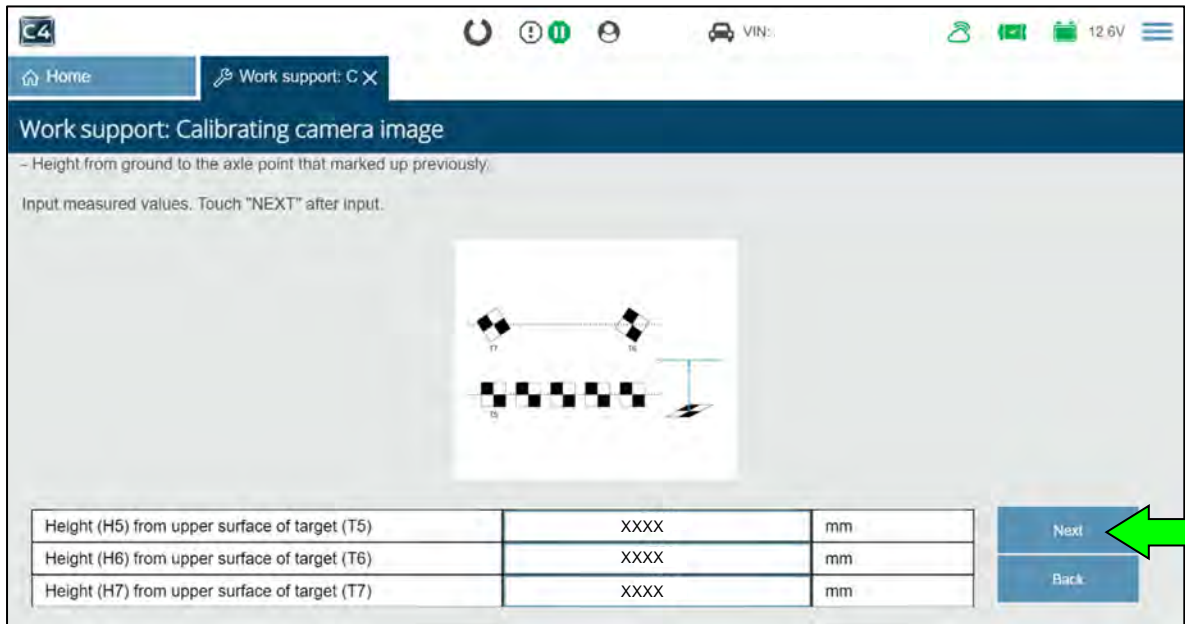

Figure 125

88. Input the height measurements H8-H11 documented for the camera being calibrated, and then select **Next**.

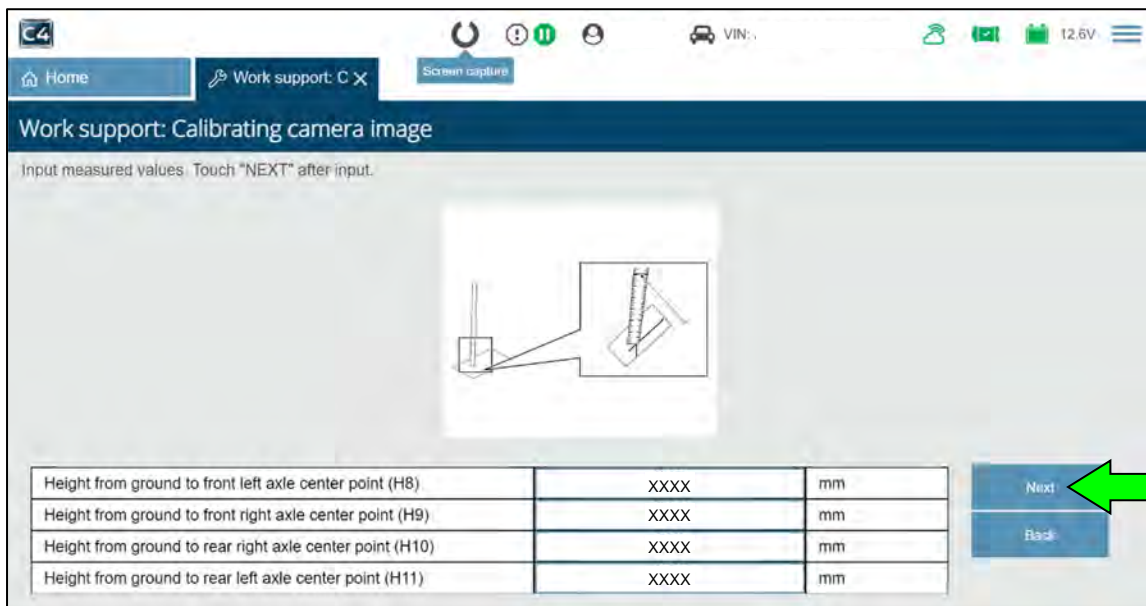

Figure 126

89. Select **OK**.

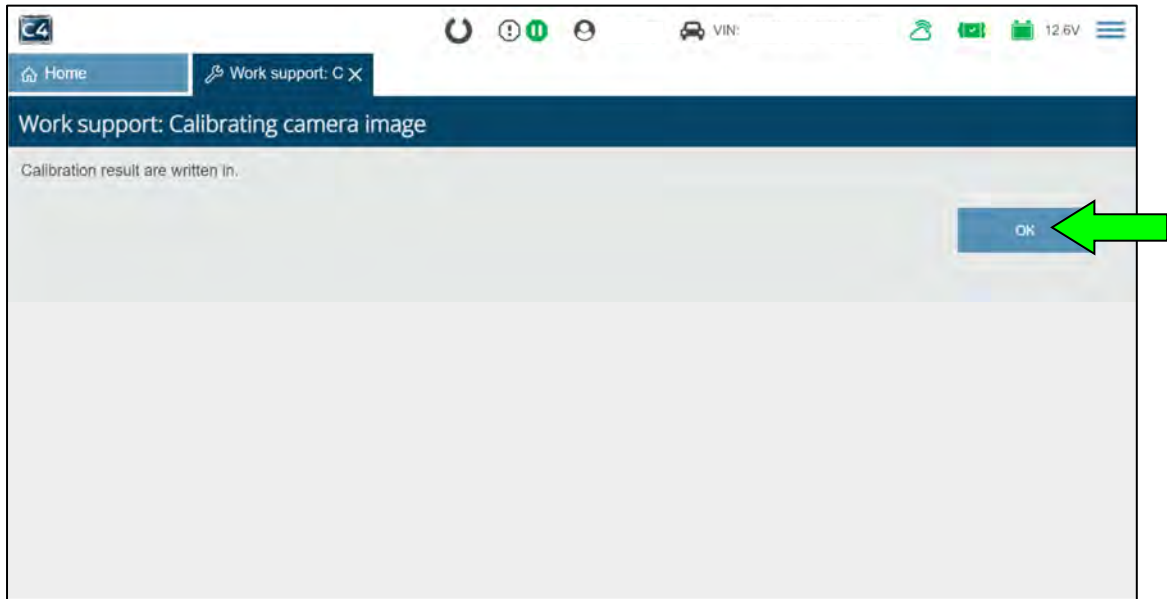

Figure 127

90. Select **Reload**.

HINT: The camera will show “No calibration data” until the **Reload** box is selected.

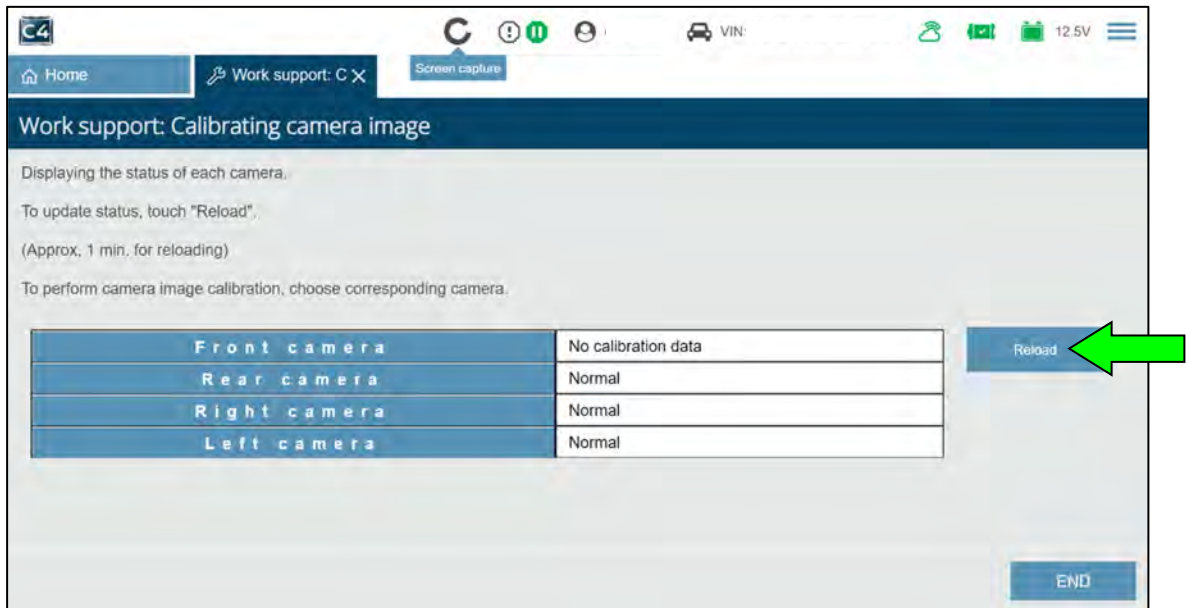

Figure 128

91. Perform steps 77 - 90 starting on page 59, for all cameras that required calibration.

92. Select **END**.

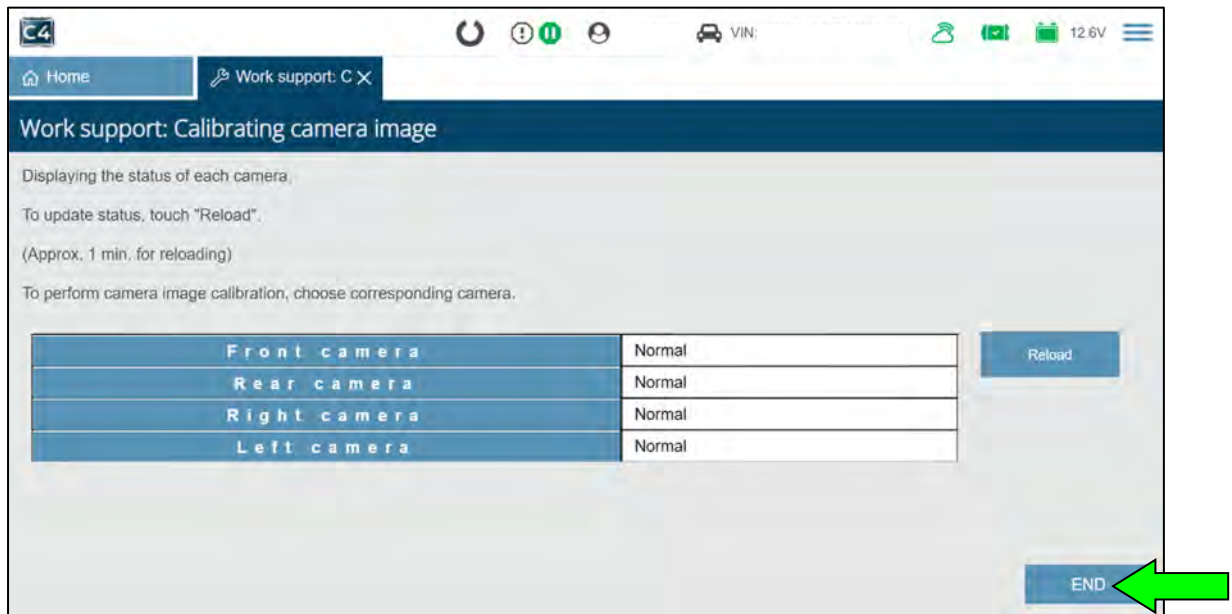

Figure 129

93. Clear all DTCs.

94. Remove the laser level from the top of the vehicle.

95. Remove all tape and markings from the vehicle.

96. Verify the ProPILOT Park function operates correctly.

- If the ProPILOT Park function operates correctly, when compared to a known good vehicle, the **SERVICE PROCEDURE** is complete.
- If the ProPILOT Park function does not operate correctly, when compared to a known good vehicle:
 - If DTCs are present, refer to the ESM for further diagnostic information.
 - If DTCs are not present and there is not a blue arrow and a blue circle with a P on the screen, as shown in Figure 130:
 - a. Disconnect both of the 12V battery cables, negative cable first.
 - Follow all ESM instructions and precautions when disconnecting the battery cables.
 - Refer to the ESM: **ELECTRICAL & POWER CONTROL > POWER SUPPLY, GROUND & CIRCUIT ELEMENTS > PRECAUTION > PRECAUTIONS FOR REMOVING BATTERY TERMINAL**
 - b. Wait 30 seconds, and then touch the cables together.
 - c. Wait 10 minutes.
 - d. Reconnect the battery cables, positive cable first.
 - e. Retry the ProPILOT Park function.



Figure 130

AMENDMENT HISTORY

PUBLISHED DATE	REFERENCE	DESCRIPTION
November 3, 2023	NTB23-076	Original bulletin published
May 14, 2024	NTB23-076A	2024 model year added to APPLIED VEHICLES , REQUIRED TOOLS on pages 2 – 4 updated