

2025 Crown Pre-Delivery Service (PDS)

Service Category General

Section Pre-Delivery Service

Market USA

Toyota Supports
 ASE Certification 

Applicability

YEAR(S)	MODEL(S)	ADDITIONAL INFORMATION
2025	Crown	

Introduction

Pre-Delivery Service (PDS) is a critical step in satisfying our new car customers. Customer feedback indicates the following areas deserve special attention when performing PDS:

- Careful inspection for paint chips/scratches and body dents/dings.
- Proper operation of electrical accessories (including interior light, clock, and radio reset).
- Interior cleanliness.
- Proper function of mechanical systems.

Customer retention and proper maintenance of vehicles are and have always been a major focus for Toyota. To help remind customers that regular service is essential to the proper maintenance of the vehicle, dealers are required to install a service reminder sticker before delivery. By doing this, customers will be reminded to return to your dealership for service. Your current service reminder sticker may be used. (See PDS Check Sheet item 8 of “Final Inspection and Cleaning.”)

This bulletin contains the PDS procedures that apply specifically to 2025 model year Crown vehicles.

Refer to [T-SB-0028-24](#), the universal *Check Sheet* that contains PDS steps that apply to all 2025 model year Toyota vehicles. To properly perform a complete PDS, you must complete all procedures contained in this TSB as well as the universal PDS Check Sheet.

In addition, if the vehicle is stored for over 30 days, refer to [T-SB-0023-24](#), *Long-Term Vehicle Storage Guidelines*.

2025 Crown Pre-Delivery Service (PDS)

Table of Contents

- [Warranty Policy](#) 3
- [Warranty Information](#) 3
- [Required Tools & Equipment](#) 3
- [D/C Cut Fuse Installation](#) 4
- [Front License Plate and Mounting Bracket Installation](#)* 5
- [Front Emergency Towing Eyelet Removal and Hole Cover Installation](#) 5
- [Installation of Rubber Body Plugs](#) 7
- [Tire Pressure Warning System \(TPWS\) Initialization](#) 8
- [Seating Position Control ECU Initialization](#) 8
- [Head Unit System Reset](#) 8
- [Customize ACC Function](#) 9
- [Dealer Contact Information for Call Dealer Head Unit Function](#) 9
- [Navigation — Set Date & Time by GPS](#) 9

*If applicable.

2025 Crown Pre-Delivery Service (PDS)

Warranty Policy

If the need for additional repairs or adjustment is noted during PDS, the required service should be performed under warranty. Reimbursement will be managed under the warranty policy.

The Warranty Policy and Procedures Manual requires that you maintain the completed Check Sheet in the customer's file. If you cannot produce a completed form for each retailed vehicle upon TMS and/or Region/Distributor audit, the PDS payment amount will be subject to debit.

An additional Repair Order completed in conjunction with normal PDS MUST have time punch/flags for service. If multiple repairs are performed, separate time flags MUST be punched for each repair.

Warranty Information

OP CODE	DESCRIPTION	MODEL	TIME	OFF	T1	T2
001013	Pre-Delivery Service (PDS)	Crown	1.1	-	-	-

Required Tools & Equipment

REQUIRED EQUIPMENT	SUPPLIER	PART NUMBER	QTY
Techstream ADVi*	ADE	TSADVUNIT	1
Techstream 2.0		TS2UNIT	
Techstream Lite		TSLITEPDLR01	
Techstream Lite (Green Cable)		TSLP2DLR01	

*Essential SST.

NOTE

- Only ONE of the Techstream units listed above is required.
- GTS+ software version 2024.01.002.02 or later is required.
- Additional Techstream units may be ordered by calling Approved Dealer Equipment (ADE) at 1-800-368-6787 or by visiting *TIS – Diagnostics – Tools & Equipment – Techstream Order Portal*.

2025 Crown Pre-Delivery Service (PDS)

D/C Cut Fuse Installation

To minimize battery discharge, the D/C cut fuse (20A) has been removed and is stored in the engine compartment relay block. Install the D/C cut fuse (20A) and confirm ALL related Diagnostic Trouble Codes (DTCs) are cleared.

Remove the D/C cut fuse (20A) from the blank space of the relay block in the engine compartment and install the D/C cut fuse (20A) in the relay block as shown.

Figure 1.

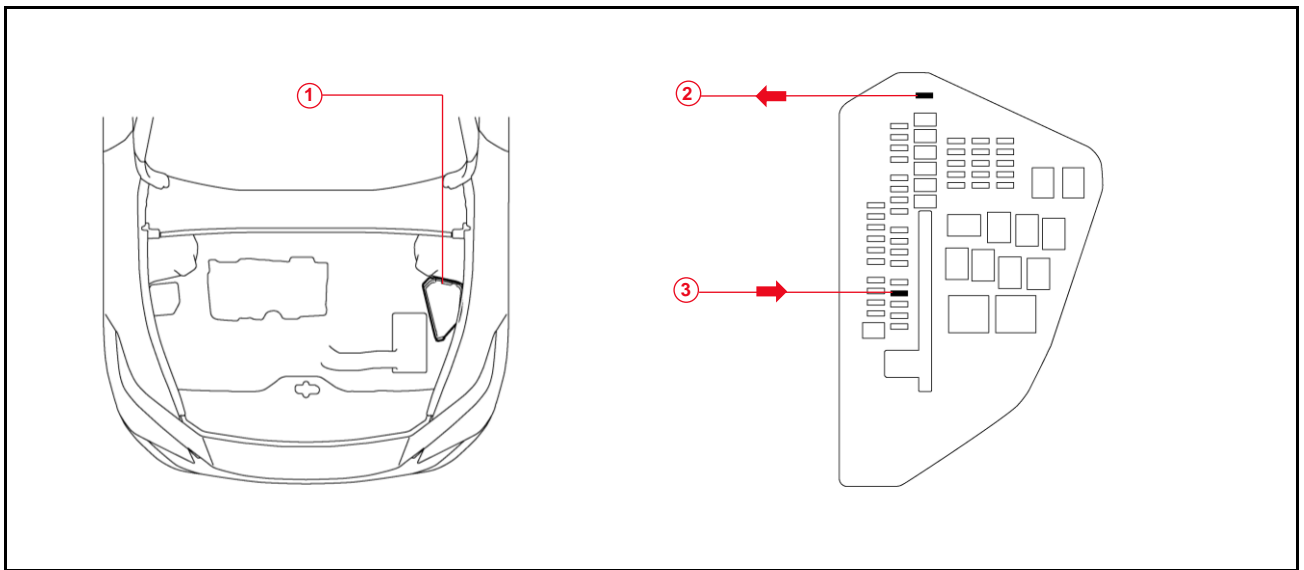

1	Relay Block
2	Remove the D/C Cut Fuse (20A)
3	Install the D/C Cut Fuse (20A)

NOTE

- With the D/C cut fuse (20A) removed, if ANY DTCs are detected when the ignition is turned ON during transportation, use Global Techstream Software (GTS+) to clear ALL DTCs AFTER ensuring there are NO malfunctions.
- While the vehicle is stored at the dealership, disconnect the negative (-) battery terminal to prevent battery discharge. Refer to [T-SB-0021-24](#), *Battery Inspection and Maintenance During PDS*, for battery maintenance information.

2025 Crown Pre-Delivery Service (PDS)

Front License Plate and Mounting Bracket Installation

The front license plate mounting bracket and four self-tapping screws are loaded in the vehicle at the assembly plant. Perform installation according to the included front license plate mounting bracket and license plate installation sheet.

NOTICE

- Do NOT drill holes through the lower grille or overtighten the self-tapping screws.

Front Emergency Towing Eyelet Removal and Hole Cover Installation

1. Remove the front emergency towing eyelets from the front bumper by turning them counterclockwise.

HINT

If it is difficult to loosen the emergency towing eyelets, use a steel bar.

2. Place one of the removed front emergency towing eyelets into the luggage tray in the luggage compartment.

HINT

Dispose of the other removed emergency towing eyelet.

Figure 2.

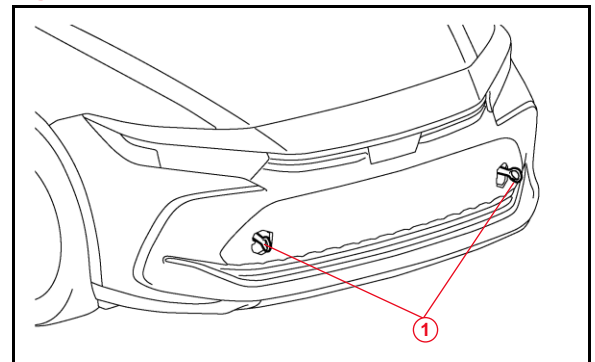

1	Front Emergency Towing Eyelets
----------	---------------------------------------

2025 Crown Pre-Delivery Service (PDS)

Front Emergency Towing Eyelet Removal and Hole Cover Installation (continued)

3. Install the front emergency towing eyelet hole covers, which are stored in the glove box, onto the front bumper.
 - A. Insert the arrow-shaped part of the emergency towing eyelet hole cover "A" into the eyelet hole "B" as shown.
 - B. Install the emergency towing eyelet hole cover to the hole of the bumper.

Figure 3.

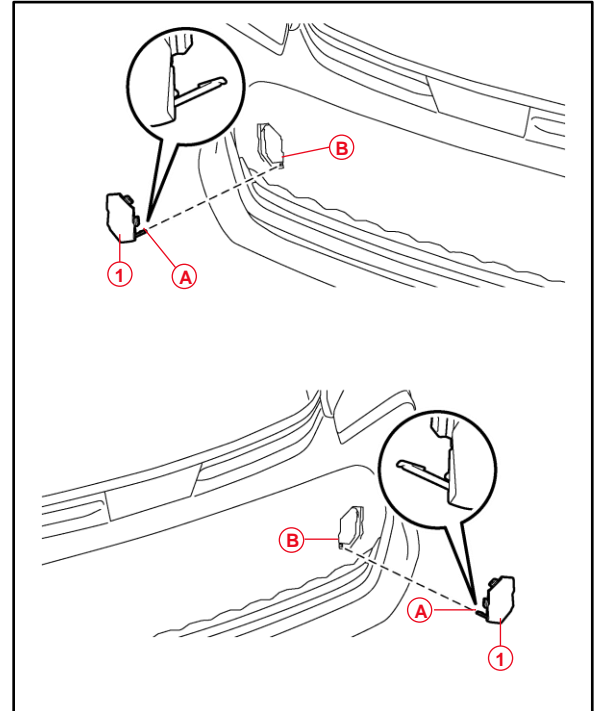

A	Arrow-shaped Part
B	Eyelet Hole
1	Front Emergency Towing Eyelet Hole Cover

2025 Crown Pre-Delivery Service (PDS)

Installation of Rubber Body Plugs

1. Confirm the number of plugs in the glove box. If two plugs are present, perform substep 2A ONLY. If four plugs are present, perform substep 2A AND substep 2B.
2. Install plugs according to the following instructions by confirming the number of plugs in the glove box.
 - A. Install two plugs in the rear side member hole or rocker inner hole.
 - B. Install two plugs in the torque box hole or rocker inner hole.

Figure 4.

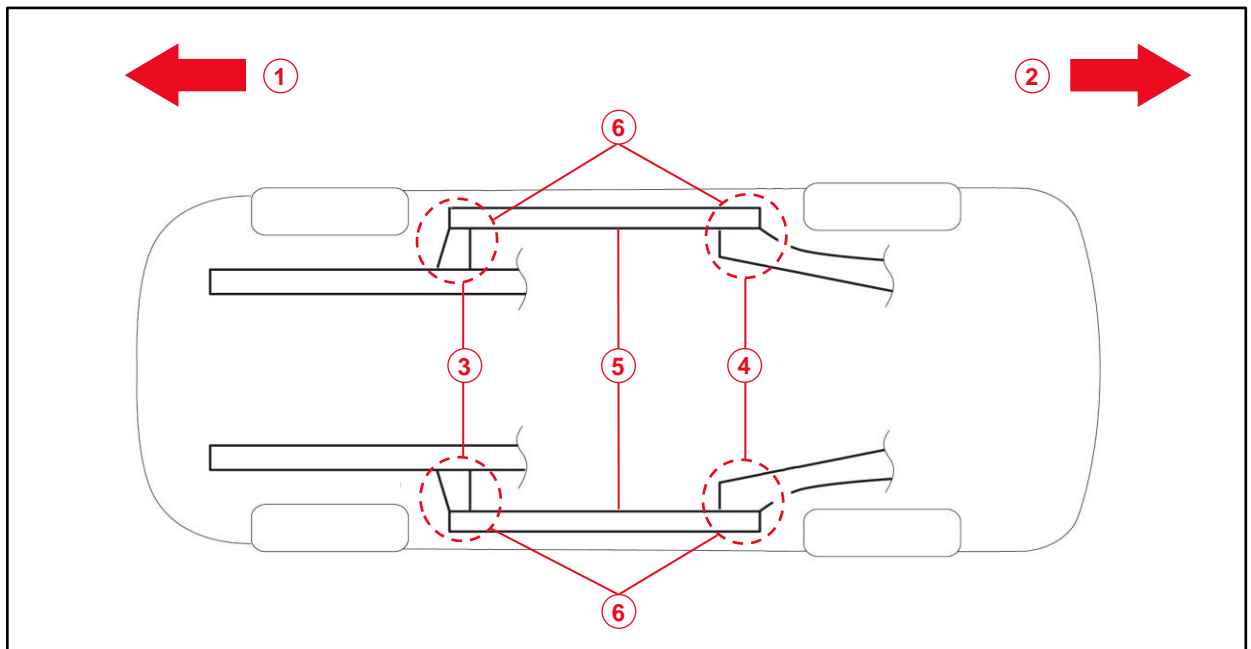

1	Front Side
2	Rear Side
3	Torque Box Hole or Rocker Inner Hole
4	Rear Side Member Hole or Rocker Inner Hole
5	Rocker Inner
6	Install Plug Here (if Applicable)

NOTICE

- The installation of these plugs is required to prevent rust.
- These plugs are stored in the glove box.
- The number of plugs may vary according to production locations in the same vehicle model.

2025 Crown Pre-Delivery Service (PDS)

Tire Pressure Warning System (TPWS) Initialization

Refer to the applicable Repair Manual for the TPWS initialization procedure.

Note the spare tire does NOT have a TPWS sensor.

- [2025](#) Crown:

Suspension – Tire Pressure Monitoring – Tire Pressure Warning Receiver – Initialization

NOTE

To adjust the tire pressure correctly when the outside temperature is significantly colder than shop temperature, perform a Health Check using GTS+ and select the compensation tire pressure checkbox. Compensation pressures will display on the Health Check results screen. Adjust the tire pressure when the tires are cold.

Seating Position Control ECU Initialization

Refer to the applicable Repair Manual for the seating position control ECU initialization procedure (procedure 2).

- [2025](#) Crown:

Vehicle Interior – Seat – Front Power Seat Control System (w/ Memory) – Registration

Head Unit System Reset

Prior to vehicle delivery, confirm that the welcome screen with language options appears on the head unit display when the ignition is switched to the ON position. There may be instances where the welcome screen with language options may not properly appear on the head unit display.

If the welcome screen showing language options is not displayed, complete the following steps:

1. Select the Settings option (gear icon).
2. Scroll down and select the Info & Security option.
3. The System Reset dialogue box will appear. Select Reset to confirm the resetting of the system.
4. Confirm that the welcome screen with language options is now displayed.

2025 Crown Pre-Delivery Service (PDS)

Customize ACC Function

The pre-startup function detects when a user enters the vehicle and energizes the audio head unit (+BA) so that the multimedia system can quickly be used. This function is not enabled at the factory to reduce parasitic current draw in transit and storage. To enable this function, it is necessary to set the ACC customization function in the navigation display to OFF.

1. Turn the engine switch (power switch) to the ON position (ON mode).
2. Enter the following menus: *Settings – Vehicle Customization – Utility – ACC Customize*.
3. Change the setting to OFF.

Dealer Contact Information for Call Dealer Head Unit Function

Refer to the *Navigation System Owner's Manual* to add dealer contact information.

- [2025](#) Crown:
Section 2-8 Vehicle settings – Setting dealer information.

Navigation — Set Date & Time by GPS

Prior to vehicle delivery, it is necessary to turn the Set Date & Time by GPS setting to the ON position.

1. Turn the engine switch (power switch) to the ON position (ON mode).
2. Navigate the following menus in the head unit: *Settings – General – Date & Time – Set date & time by GPS*.
3. Ensure the Set Date & Time by GPS function is set to the ON position.