

Technical Service Bulletin

Mazda North American Operations
Irvine, CA 92618-2922



Subject: NO SOUND FROM AUDIO SYSTEM, RADIO STATION CHANGES OR UNABLE TO CHANGE AUDIO SOURCE	Bulletin No.: 09-030/24
	Last Issued : 06/06/2024

BULLETIN NOTES

This bulletin supersedes the previously issued bulletin(s) listed below. The changes are noted in Red.

Previous TSBs:	Date(s) Issued:
09-039/23	11/14/23 and 12/12/23

APPLICABLE MODEL(S)/VINS

2023-2024 CX-30 vehicles with VINs lower than 3MV DM **** ** 652068 (Produced before Jan. 17, 2024)

2023-2024 CX-5 (except Mexico spec.) vehicles with VINs lower than JM3 KF **** ** 454094 (Produced before Dec. 27, 2023)

2025 CX-70 vehicles with VINs lower than JM3 KJ **** ** 100232 (Produced before Jan. 19, 2024)

2023 CX-9 vehicles with VINs lower than JM3 TC **** ** 660048 (Produced before Mar. 31, 2023)

2024 CX-90 vehicles with VINs lower than JM3 KK**** ** 159740 (Produced before Feb. 13, 2024)

2023-2024 Mazda3 (Japan built) vehicles with VINs lower than JM1 BP **** ** 714946 (Produced before Feb. 13, 2024)

2023-2024 Mazda3 (Mexico built) vehicles with VINs lower than 3MZ BP **** ** 414287 (Produced before Jan. 17, 2024)

2022-2023 MX-30 vehicles with VINs lower than JM1DR*****200910 (Produced before May 29, 2023)

NOTE: Even if the vehicle is within the subject VIN range above, it may not be applicable to this Service Information depending on the hardware version of the remote tuner. Refer to the target hardware number in the repair procedure.

Trademarks: SiriusXM® is a registered trademark of Sirius XM Radio Inc.

DESCRIPTION

Some customers may experience the following symptoms:

- No sound from some audio sources (AM, FM, SiriusXM®) after turning the ignition on.
- Radio station selection (AM, FM, SiriusXM®) changes unintentionally after turning the ignition on.
- Audio source cannot be changed.

Diagnosing according to MGSS online does not solve the problem.

These concerns may be caused by the remote tuner not operating properly under certain situations. To eliminate these

CONSUMER NOTICE: The information and instructions in this bulletin are intended for use by skilled technicians. Mazda technicians utilize the proper tools/ equipment and take training to correctly and safely maintain Mazda vehicles. These instructions should not be performed by "do-it-yourselfers." Customers should not assume this bulletin applies to their vehicle or that their vehicle will develop the described concern. To determine if the information applies, customers should contact their nearest authorized Mazda dealership. Mazda North American Operations reserves the right to alter the specifications and contents of this bulletin without obligation or advance notice. All rights reserved. No part of this bulletin may be reproduced in any form or by any means, electronic or mechanical--including photocopying and recording and the use of any kind of information storage and retrieval system ---without permission in writing.

concerns, the remote tuner control software has been modified.

Customers having this concern should have their vehicle repaired using the following repair procedure.

REPAIR PROCEDURE

1. Verify the concern by confirming the audio system volume is not muted or set to 0.
2. Confirm if any audio system DTCs are stored.
 - If any audio system DTCs are stored, this Service Information is not applicable. Diagnose the DTCs according to the online instructions on MGSS.
 - If no audio system DTCs are stored, proceed to the repair procedure below to reprogram the remote tuner control software.

Update the control software of the remote tuner following the steps below:

1. Connect a battery charger to the vehicle.

NOTE: Before beginning the reprogramming procedure, explain the following points to the customer regarding the MyMazda App.

- **DO NOT** use the remote control features (remote engine start/stop, remote door lock/unlock, turn on/off hazard warning lights) with the MyMazda App during the repair.
 - Malfunction information may be sent for the DTC detected during the repair.
2. **Confirm the part number of the remote tuner:** Press and hold the "Volume" knob, then press and hold the "Entertainment" and "Favorites" buttons at the same time for 3-5 seconds. The "Factory/Service Inspection" screen will appear.

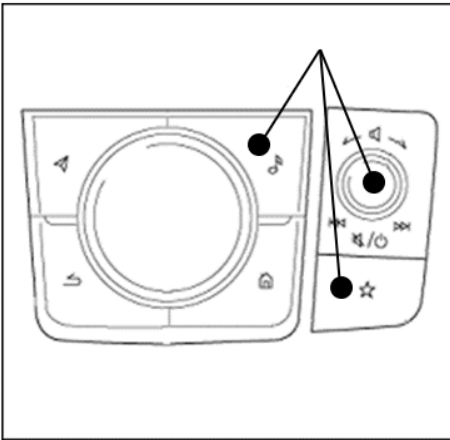

[Mazda3, CX-30, MX-30, CX-70, CX-90]

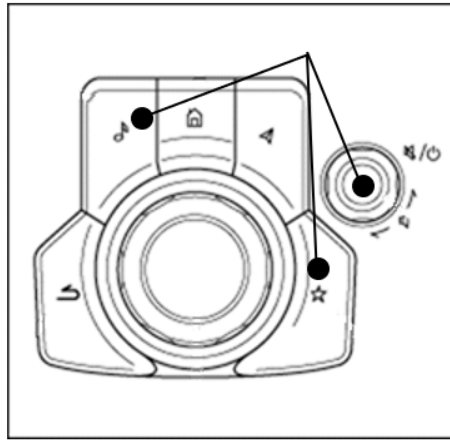

[CX-5, CX-9]

- a. Select "Service Information" on the screen below.

CONSUMER NOTICE: The information and instructions in this bulletin are intended for use by skilled technicians. Mazda technicians utilize the proper tools/ equipment and take training to correctly and safely maintain Mazda vehicles. These instructions should not be performed by "do-it-yourselfers." Customers should not assume this bulletin applies to their vehicle or that their vehicle will develop the described concern. To determine if the information applies, customers should contact their nearest authorized Mazda dealership. Mazda North American Operations reserves the right to alter the specifications and contents of this bulletin without obligation or advance notice. All rights reserved. No part of this bulletin may be reproduced in any form or by any means, electronic or mechanical--including photocopying and recording and the use of any kind of information storage and retrieval system ---without permission in writing.



b. Select "Connected Device Information".

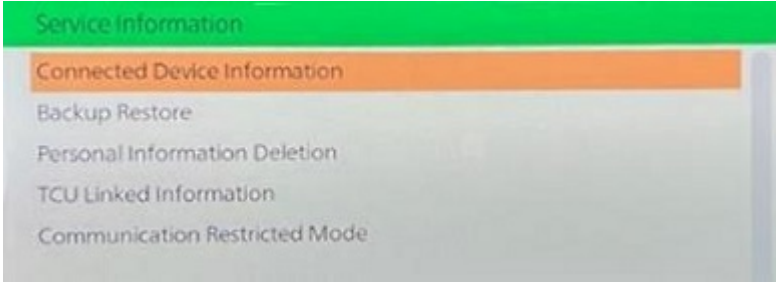

c. Select "RT".

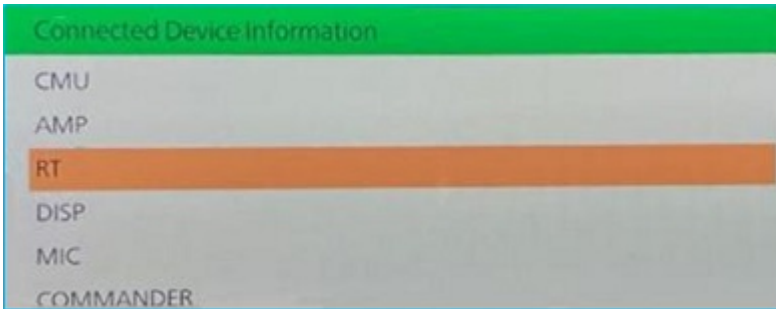

CONSUMER NOTICE: The information and instructions in this bulletin are intended for use by skilled technicians. Mazda technicians utilize the proper tools/ equipment and take training to correctly and safely maintain Mazda vehicles. These instructions should not be performed by "do-it-yourselfers." Customers should not assume this bulletin applies to their vehicle or that their vehicle will develop the described concern. To determine if the information applies, customers should contact their nearest authorized Mazda dealership. Mazda North American Operations reserves the right to alter the specifications and contents of this bulletin without obligation or advance notice. All rights reserved. No part of this bulletin may be reproduced in any form or by any means, electronic or mechanical---including photocopying and recording and the use of any kind of information storage and retrieval system ---without permission in writing.

d. Confirm the "Part No." of the RT and find it in the table below under "Target Hardware".

Device Version Information		RT
Device Name/Ver. :	DSP_Program / XXXXXXXX	
Device Name/Ver. :	DSP_Data / XXXXXXXX	
Device Name/Ver. :	MOST_CPU / XXXXXX	
Device Name/Ver. :	DTV_CPU / XXXX	
Serial No. :		
Part No. :	XXXX-66DR0-X	

NOTE: The last number of the file name may be 5 digits or 4 digits (i.e. 26020 or 2620) depending on the time of manufacturing.

Model	Target Hardware	HD	SATEL-LITE	File Name	Software Version
Mazda3 (JM1) CX-70 CX-9 CX-90 MX-30	BDGF- 66-DR0A or later	X	-	RT_7000R0A-BD GF_26020.kwi RT_7000R0A-BD GF_2620.kwi	26020
Mazda3 (JM1) CX-9 CX-90 MX-30	BDGG- 66-DR0A or later	X	X	RT_7000R0A-BD GG_26020.kwi RT_7000R0A-BD GG_2620.kwi	26020
2024 Mazda3 (JM 1) CX-70 CX-90	KMV7- 66-DR0A or later	-	-	RT_7000R0A-KM V7_24019.kwi RT_7000R0A-KM V7_2419.kwi	24019
CX-5	KJK9- 66-DR0A or later	X	-	RT_7000R0A-KJK 9_23018.kwi RT_7000R0A-KJK 9_2318.kwi	23018
CX-5	KJL1- 66-DR0A or later	X	X	RT_7000R0A-KJL 1_23018.kwi RT_7000R0A-KJL 1_2318.kwi	23018
Mazda3 (3MZ) CX-30	BDTS- 66-DR0A or later	X	-	RT_7000R0A-BD TS_26020.kwi RT_7000R0A-BD TS_2620.kwi	26020
Mazda3 (3MZ) CX-30	BDTT- 66-DR0A or later	X	X	RT_7000R0A-BD TT_26020.kwi RT_7000R0A-BD TT_2620.kwi	26020

CONSUMER NOTICE: The information and instructions in this bulletin are intended for use by skilled technicians. Mazda technicians utilize the proper tools/ equipment and take training to correctly and safely maintain Mazda vehicles. These instructions should not be performed by "do-it-yourselfers." Customers should not assume this bulletin applies to their vehicle or that their vehicle will develop the described concern. To determine if the information applies, customers should contact their nearest authorized Mazda dealership. Mazda North American Operations reserves the right to alter the specifications and contents of this bulletin without obligation or advance notice. All rights reserved. No part of this bulletin may be reproduced in any form or by any means, electronic or mechanical--including photocopying and recording and the use of any kind of information storage and retrieval system ---without permission in writing.

2024 Mazda3 (3M Z) 2024 CX-30	VA40-66-DR0B or later	-	-	RT_7000R0A-VA40_24019.kwi RT_7000R0A-VA40_2419.kwi	24019
CX-70	KR9D-66DR0 or later	X	X	RT_7000R0A-KR9D_28008.kwi RT_7000R0A-KR9D_2808.kwi	28008

CONSUMER NOTICE: The information and instructions in this bulletin are intended for use by skilled technicians. Mazda technicians utilize the proper tools/ equipment and take training to correctly and safely maintain Mazda vehicles. These instructions should not be performed by "do-it-yourselfers." Customers should not assume this bulletin applies to their vehicle or that their vehicle will develop the described concern. To determine if the information applies, customers should contact their nearest authorized Mazda dealership. Mazda North American Operations reserves the right to alter the specifications and contents of this bulletin without obligation or advance notice. All rights reserved. No part of this bulletin may be reproduced in any form or by any means, electronic or mechanical---including photocopying and recording and the use of any kind of information storage and retrieval system ---without permission in writing.

3. Download the update file from MGSS.
4. Format a USB flash drive.
5. Download the latest software for the vehicle to a USB flash drive.

NOTE: When downloading the software file to the USB flash drive, refer to the MAZDA CONNECT Updates page on MGSS (under "Infotainment/TCU" tab), introducing precautions for reprogramming with a USB flash drive.

6. Prepare the USB flash drive which contains the software file(s) to be installed.

NOTE: All 18 files shown in the table above can be stored in one USB flash drive. The vehicle will select the applicable file.

7. Turn the ignition switch to ON (engine OFF) with the push button start.

PHEV: While depressing the brake pedal, push the power switch to turn the power ON (READY ON).

CAUTION: To avoid damaging the remote tuner, do not remove the USB flash drive or turn the ignition switch OFF while reprogramming.

8. Insert the USB flash drive into any USB port.

9. Press and hold the "Volume" knob, then press and hold the "Entertainment" and "Favorites" buttons at the same time for 3-5 seconds. The "Factory/Service Inspection" screen will appear.

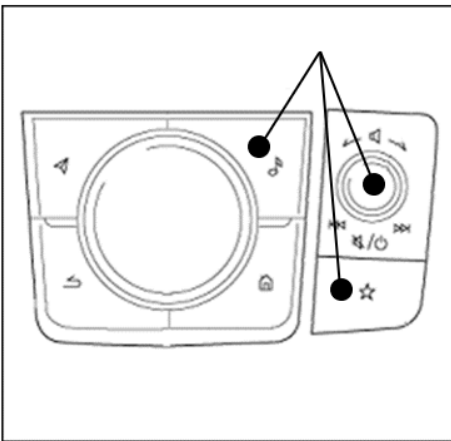

[Mazda3, CX-30, MX-30, CX-70, CX-90]

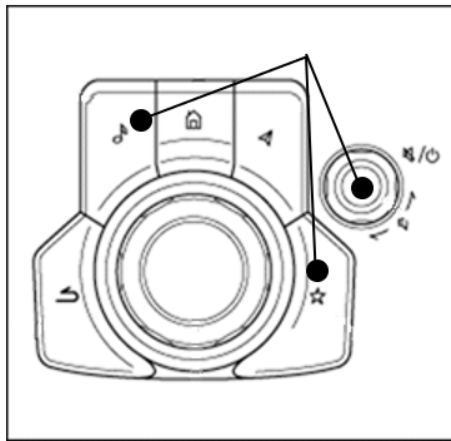

[CX-5, CX-9]

10. Select "Device Program Update" on the screen below.



11. Select "System Update" on the screen below.

CONSUMER NOTICE: The information and instructions in this bulletin are intended for use by skilled technicians. Mazda technicians utilize the proper tools/ equipment and take training to correctly and safely maintain Mazda vehicles. These instructions should not be performed by "do-it-yourselfers." Customers should not assume this bulletin applies to their vehicle or that their vehicle will develop the described concern. To determine if the information applies, customers should contact their nearest authorized Mazda dealership. Mazda North American Operations reserves the right to alter the specifications and contents of this bulletin without obligation or advance notice. All rights reserved. No part of this bulletin may be reproduced in any form or by any means, electronic or mechanical---including photocopying and recording and the use of any kind of information storage and retrieval system ---without permission in writing.

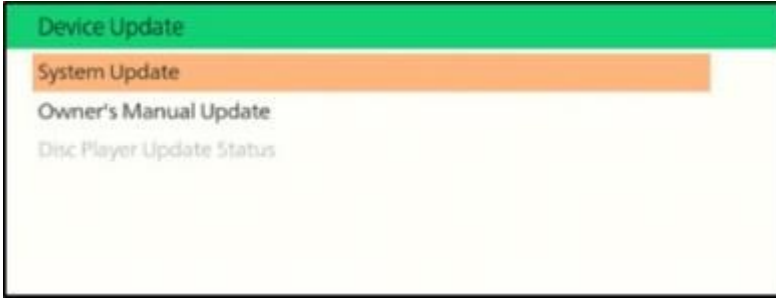

12. Select "USB" on the screen below to start checking for the update file.



NOTE: If the "Update file(s) not found" message appears, the wrong file may be stored in the USB flash drive or the vehicle has already been updated.

CONSUMER NOTICE: The information and instructions in this bulletin are intended for use by skilled technicians. Mazda technicians utilize the proper tools/ equipment and take training to correctly and safely maintain Mazda vehicles. These instructions should not be performed by "do-it-yourselfers." Customers should not assume this bulletin applies to their vehicle or that their vehicle will develop the described concern. To determine if the information applies, customers should contact their nearest authorized Mazda dealership. Mazda North American Operations reserves the right to alter the specifications and contents of this bulletin without obligation or advance notice. All rights reserved. No part of this bulletin may be reproduced in any form or by any means, electronic or mechanical---including photocopying and recording and the use of any kind of information storage and retrieval system ---without permission in writing.

13. Confirm the correct software version is shown under "Update Version" and select "TUNER ASSY" on the screen below.



Update Version

(Refer to step 2)

14. Select "OK" on the screen below and wait until the update (loading) is completed.

NOTE: DO NOT switch the ignition OFF until the update (loading) is completed.

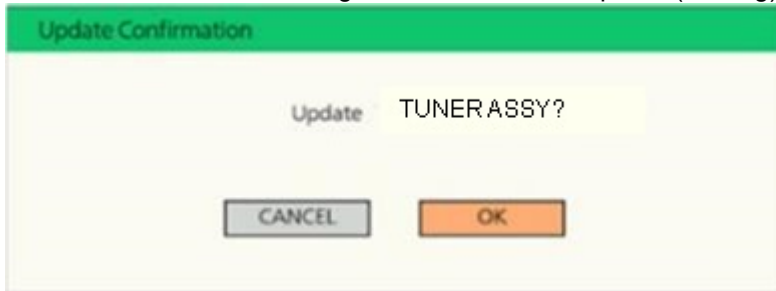

15. Select "OK" on the screen below. The data update will start automatically after 10 seconds if "OK" is not selected.

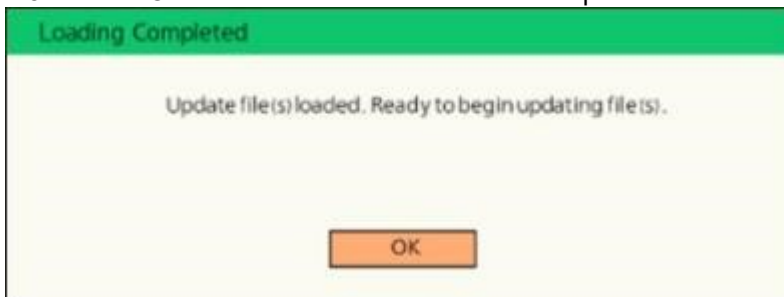

NOTE: After selecting "OK", the system will reboot and the display will turn black, followed by screens below:

- Sending update file(s)
- Checking update file(s)
- Installing update file(s)
- Completed

CONSUMER NOTICE: The information and instructions in this bulletin are intended for use by skilled technicians. Mazda technicians utilize the proper tools/ equipment and take training to correctly and safely maintain Mazda vehicles. These instructions should not be performed by "do-it-yourselfers." Customers should not assume this bulletin applies to their vehicle or that their vehicle will develop the described concern. To determine if the information applies, customers should contact their nearest authorized Mazda dealership. Mazda North American Operations reserves the right to alter the specifications and contents of this bulletin without obligation or advance notice. All rights reserved. No part of this bulletin may be reproduced in any form or by any means, electronic or mechanical--including photocopying and recording and the use of any kind of information storage and retrieval system ---without permission in writing.

16. Wait until update is completed (takes approx. 10 minutes).

NOTE:

- If a warning message like "Vehicle network error" appears, continue the updating.
- If a red warning message "Update Error" appears, lock all doors and wait for 5 minutes or more so that the vehicle goes into sleep mode, then turn on the ACC position.

17. When the "Completed" screen appears, press the commander knob to reboot the system.

18. After rebooting is completed, remove the USB flash drive from the USB port.

19. Repeat Step 9 by pressing and holding the "Volume" knob, then press and hold the "Entertainment" and "Favorites" buttons at the same time for 3-5 seconds. The "Factory/Service Inspection" screen will appear.

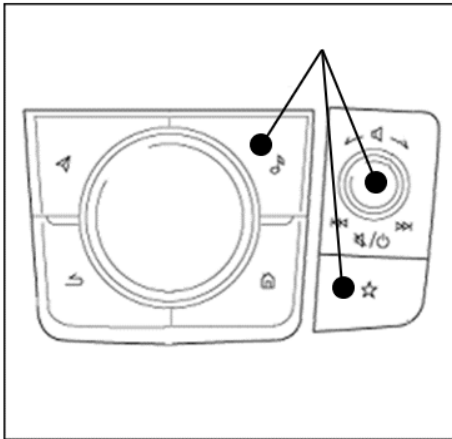

[Mazda3, CX-30, MX-30, CX-70, CX-90]

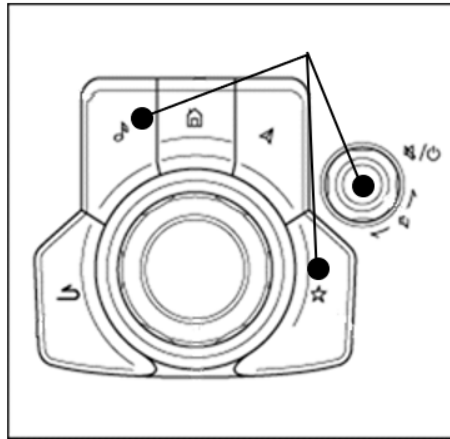

[CX-5, CX-9]

20. Select "Service Information" on the screen below.



21. Select "Connected Device Information".

CONSUMER NOTICE: The information and instructions in this bulletin are intended for use by skilled technicians. Mazda technicians utilize the proper tools/ equipment and take training to correctly and safely maintain Mazda vehicles. These instructions should not be performed by "do-it-yourselfers." Customers should not assume this bulletin applies to their vehicle or that their vehicle will develop the described concern. To determine if the information applies, customers should contact their nearest authorized Mazda dealership. Mazda North American Operations reserves the right to alter the specifications and contents of this bulletin without obligation or advance notice. All rights reserved. No part of this bulletin may be reproduced in any form or by any means, electronic or mechanical---including photocopying and recording and the use of any kind of information storage and retrieval system ---without permission in writing.

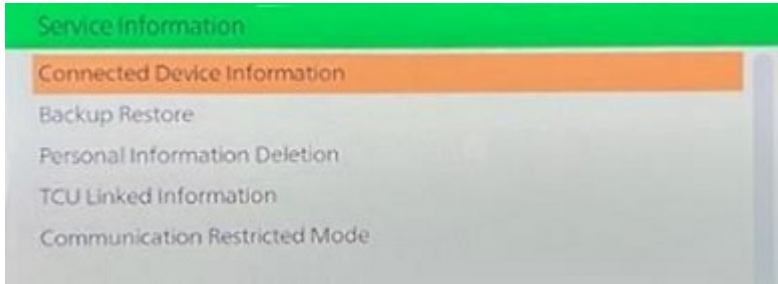

22. Select "RT".

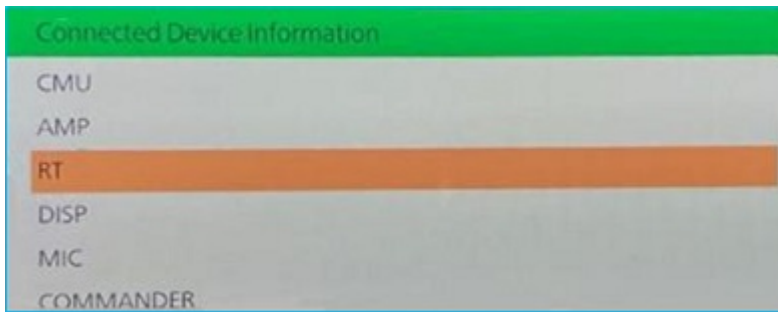

CONSUMER NOTICE: The information and instructions in this bulletin are intended for use by skilled technicians. Mazda technicians utilize the proper tools/ equipment and take training to correctly and safely maintain Mazda vehicles. These instructions should not be performed by "do-it-yourselfers." Customers should not assume this bulletin applies to their vehicle or that their vehicle will develop the described concern. To determine if the information applies, customers should contact their nearest authorized Mazda dealership. Mazda North American Operations reserves the right to alter the specifications and contents of this bulletin without obligation or advance notice. All rights reserved. No part of this bulletin may be reproduced in any form or by any means, electronic or mechanical---including photocopying and recording and the use of any kind of information storage and retrieval system ---without permission in writing.

23. Confirm that the software version has been updated.



File Name

(Refer to step 2)

24. Push Return multiple times to return to the top page of the "Factory/Service Inspection" screen, then select "End Diag Mode" to return to the normal screen.

25. When the home screen appears, turn the power off.

26. Check DTC with the Mazda Modular Diagnostic System (M-MDS), using Mazda Diagnostic And Repair Software (MDARS). If any DTCs are present, clear them.

NOTE: If MDARS has been connected before starting the reprogramming, manually obtain the ODR data through the Diagnostic Data Collection menu to keep the record of the completion of the reprogramming in the central server (automatically uploaded).

- 1) Select the "Toolbox" tab.
- 2) Select the "vehicle" icon.
- 3) Select "Collect Diagnostic Information", then click "Run".
- 4) Turn the ignition ON, then select "Next".
- 5) Confirm the message "ODR collection has been successful."

27. Confirm if the ODR collection has been done successfully.

- 1) Select "Vehicle History" in the "Toolbox", then click "Run".
- 2) Select "Collect Diagnostic Information (Automatic)" and confirm the result.

CONSUMER NOTICE: The information and instructions in this bulletin are intended for use by skilled technicians. Mazda technicians utilize the proper tools/ equipment and take training to correctly and safely maintain Mazda vehicles. These instructions should not be performed by "do-it-yourselfers." Customers should not assume this bulletin applies to their vehicle or that their vehicle will develop the described concern. To determine if the information applies, customers should contact their nearest authorized Mazda dealership. Mazda North American Operations reserves the right to alter the specifications and contents of this bulletin without obligation or advance notice. All rights reserved. No part of this bulletin may be reproduced in any form or by any means, electronic or mechanical--including photocopying and recording and the use of any kind of information storage and retrieval system ---without permission in writing.

WARRANTY INFORMATION**NOTE:**

- This warranty information applies only to verified customer complaints on vehicles eligible for warranty repair.
- This repair will be covered under Mazda's New Vehicle Limited Warranty term.
- Additional diagnostic time cannot be claimed for this repair.

Warranty Type	A
Symptom Code	58
Damage Code	9W
Part Number Main Cause	5555-66-DR0
Quantity	0
Operation Number / Labor Hours:	XXWGFAFX / 0.3 Hrs.

NOTE: Keep a record of successful reprogramming by taking a picture of the Mazda Connect display, showing the actual software version.

CONSUMER NOTICE: The information and instructions in this bulletin are intended for use by skilled technicians. Mazda technicians utilize the proper tools/ equipment and take training to correctly and safely maintain Mazda vehicles. These instructions should not be performed by "do-it-yourselfers." Customers should not assume this bulletin applies to their vehicle or that their vehicle will develop the described concern. To determine if the information applies, customers should contact their nearest authorized Mazda dealership. Mazda North American Operations reserves the right to alter the specifications and contents of this bulletin without obligation or advance notice. All rights reserved. No part of this bulletin may be reproduced in any form or by any means, electronic or mechanical---including photocopying and recording and the use of any kind of information storage and retrieval system ---without permission in writing.