

# Technical Service Bulletin

Mazda North American Operations  
Irvine, CA 92618-2922



<b>Subject:</b>  CHECK ENGINE LIGHT ON WITH DTC P0126:00	<b>Bulletin No.:</b> 01-005/24
	<b>Last Issued :</b> 06/27/2024

## BULLETIN NOTES

This bulletin supersedes the previously issued bulletin(s) listed below. The changes are noted in Red text.

Previous TSBs:	Date(s) Issued:
01-005/24	06/10/24
01-005/23	02/16/23 and 12/20/23
01-013/22	10/19/22
01-011/21	09/27/21 and 04/22/21

## APPLICABLE MODEL(S)/VINS

- 2019-2022 CX-3 2.0/2.5L with VINs lower than JM1DK\*\*\*\*\*605934 (produced before July 8, 2022)
- 2020-2024 CX-30 2.0/2.5L
- 2018-2020 CX-5 2.0/2.5L with VINs lower than JM3KF\*\*\*\*\*869654 (produced before Aug. 24, 2020)
- 2021-2024 CX-5 2.0/2.5L
- 2019-2024 Mazda3 2.0/2.5L (Japan built)
- 2019-2024 Mazda3 2.0/2.5L (Mexico built)
- 2018-2021 Mazda6 2.0/2.5L with VINs lower than JM1GL\*\*\*\*\*620105 (produced before Nov. 12, 2021)

**NOTE:** Vehicles with SKYACTIV-G 2.5T (turbo) engine are not applicable to this service information.

## DESCRIPTION

Some customers may experience a check engine light ON with DTC P0126:00 (Thermostat stuck open) and one or more of the following symptoms:

- Engine takes longer to warm up.
- Engine temperature gauge fluctuates.
- Low coolant temperature indicator (blue) light stays on longer or turns on while driving.
- Poor heater performance, especially at idle.

## NOTE:

- Vehicles with SKYACTIV-G 2.5T are not applicable to this service information.
- If DTC P2B61:00 (Coolant control valve circuit range/performance) accompanies DTC P0126:00, this TSB is not

Page 1 of 7

**CONSUMER NOTICE:** The information and instructions in this bulletin are intended for use by skilled technicians. Mazda technicians utilize the proper tools/ equipment and take training to correctly and safely maintain Mazda vehicles. These instructions should not be performed by "do-it-yourselfers." Customers should not assume this bulletin applies to their vehicle or that their vehicle will develop the described concern. To determine if the information applies, customers should contact their nearest authorized Mazda dealership. Mazda North American Operations reserves the right to alter the specifications and contents of this bulletin without obligation or advance notice. All rights reserved. No part of this bulletin may be reproduced in any form or by any means, electronic or mechanical--including photocopying and recording and the use of any kind of information storage and retrieval system ---without permission in writing.

applicable. Diagnose DTCs according to the instructions on MGSS online.

Customers having this concern should have their vehicle repaired using the following repair procedure.

## REPAIR PROCEDURE

**NOTE:** If DTC P2B61:00 (Coolant control valve circuit range/performance) registered, this Service Information is not applicable. Diagnose according to the instruction on MGSS online.

1. Verify customer concerns and check the coolant temperature in the freeze frame data.
  - If it is at around 40-80 °C {104-176 °F} proceed to step 2.
  - If it is not at around 40-80 °C {104-176 °F}, this Service Information is not applicable. Diagnose according to the instruction on MGSS online.
2. Remove the coolant control valve according to the instruction on MGSS:
  - Mazda3 (COOLANT CONTROL VALVE REMOVAL/INSTALLATION)
  - Mazda6 (COOLANT CONTROL VALVE REMOVAL/INSTALLATION)
  - CX-3 (COOLANT CONTROL VALVE REMOVAL/INSTALLATION)
  - CX-5 (COOLANT CONTROL VALVE REMOVAL/INSTALLATION)
  - CX-30 (COOLANT CONTROL VALVE REMOVAL/INSTALLATION)
3. Remove thermostat cover and thermostat cover gasket from coolant control valve.

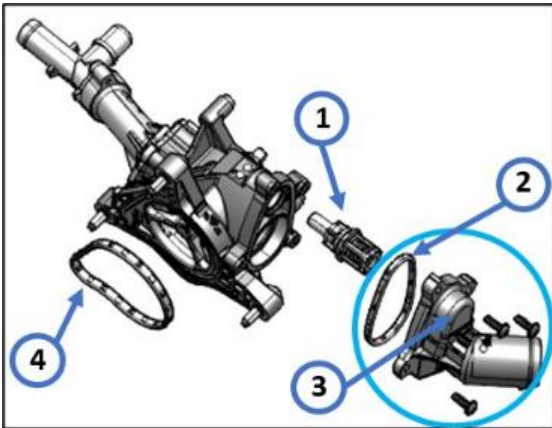

1. Thermostat
2. Thermostat cover gasket
3. Thermostat cover
4. Water outlet gasket

a. Mark the four (4) screws and the respective holes before loosening them to ensure that the screws are placed in their original holes when reinstalling.

**NOTE:** If the screws are not reinstalled in their original holes, the holes may become deformed.

**CONSUMER NOTICE:** The information and instructions in this bulletin are intended for use by skilled technicians. Mazda technicians utilize the proper tools/ equipment and take training to correctly and safely maintain Mazda vehicles. These instructions should not be performed by "do-it-yourselfers." Customers should not assume this bulletin applies to their vehicle or that their vehicle will develop the described concern. To determine if the information applies, customers should contact their nearest authorized Mazda dealership. Mazda North American Operations reserves the right to alter the specifications and contents of this bulletin without obligation or advance notice. All rights reserved. No part of this bulletin may be reproduced in any form or by any means, electronic or mechanical--including photocopying and recording and the use of any kind of information storage and retrieval system ---without permission in writing.

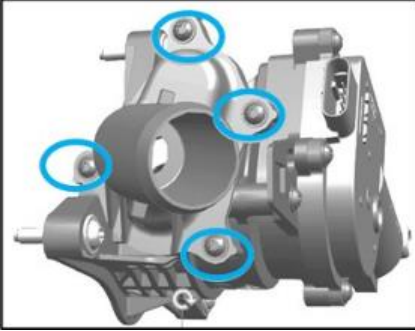

**Marking Example 1:** Draw lines over the screws and the thermostat cover as shown above.

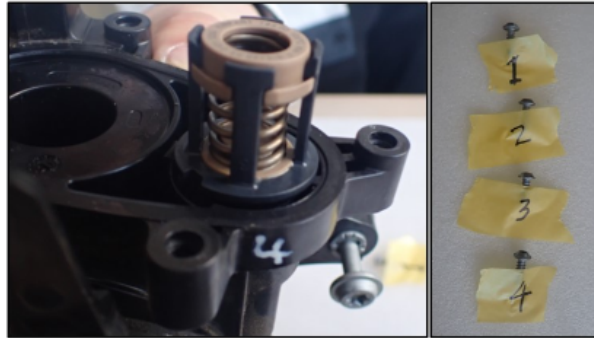

**Marking Example 2:** Number each screw and their respective hole as shown above.

b. Loosen the four (4) tapping screws fastening the thermostat cover.

**CAUTION:** Use hand tools only, do not use power tools.

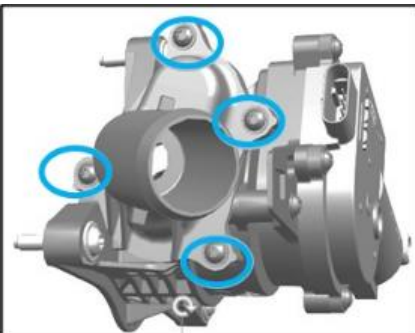

4. Replace the thermostat with a new one included in the thermostat set.

**NOTE:** Do not use lubricants, spray lube, silicone sealer or petroleum grease on any of the gaskets.

**CONSUMER NOTICE:** The information and instructions in this bulletin are intended for use by skilled technicians. Mazda technicians utilize the proper tools/ equipment and take training to correctly and safely maintain Mazda vehicles. These instructions should not be performed by "do-it-yourselfers." Customers should not assume this bulletin applies to their vehicle or that their vehicle will develop the described concern. To determine if the information applies, customers should contact their nearest authorized Mazda dealership. Mazda North American Operations reserves the right to alter the specifications and contents of this bulletin without obligation or advance notice. All rights reserved. No part of this bulletin may be reproduced in any form or by any means, electronic or mechanical---including photocopying and recording and the use of any kind of information storage and retrieval system ---without permission in writing.

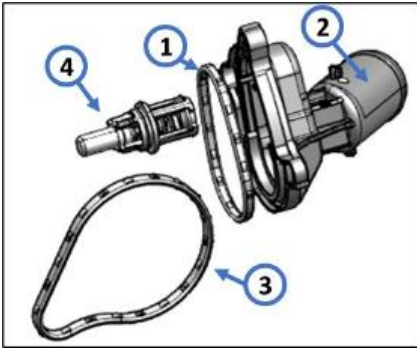
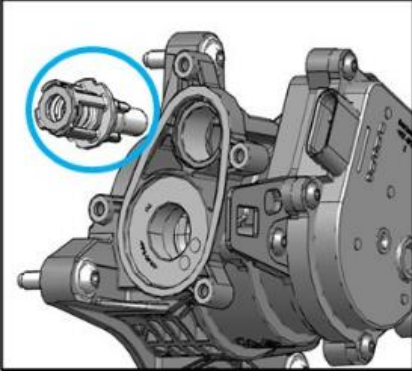

**Thermostat set includes:**

1. Thermostat cover gasket\*
2. Thermostat cover
3. Water outlet gasket
4. Thermostat

\*Thermostat cover gasket is already assembled to the thermostat cover.

- a. Before installing the thermostat, check the mounting area for dirt and clean the area.

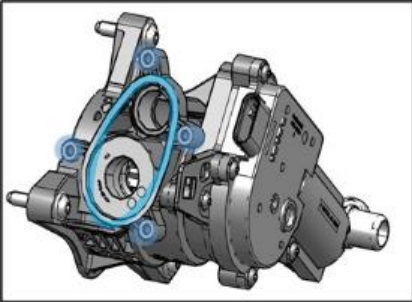

- b. When installing the thermostat, push it firmly until it makes a clicking noise to ensure it has been installed properly.

**NOTE:**

- Insert the thermostat so that its notch matches the protruding area in the hole.
- Add 1-2 drops of coolant as necessary to the O-ring to help slide it into the thermostat housing.

**CONSUMER NOTICE:** The information and instructions in this bulletin are intended for use by skilled technicians. Mazda technicians utilize the proper tools/ equipment and take training to correctly and safely maintain Mazda vehicles. These instructions should not be performed by "do-it-yourselfers." Customers should not assume this bulletin applies to their vehicle or that their vehicle will develop the described concern. To determine if the information applies, customers should contact their nearest authorized Mazda dealership. Mazda North American Operations reserves the right to alter the specifications and contents of this bulletin without obligation or advance notice. All rights reserved. No part of this bulletin may be reproduced in any form or by any means, electronic or mechanical---including photocopying and recording and the use of any kind of information storage and retrieval system ---without permission in writing.

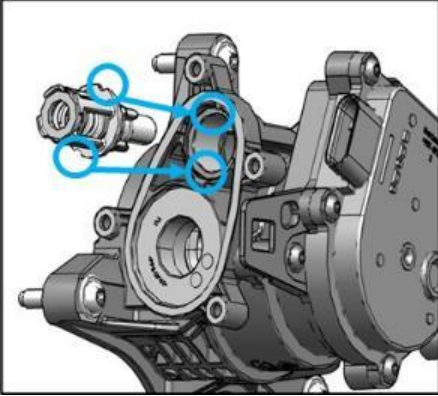

5. Install the new thermostat cover and the thermostat cover gasket (included in the thermostat set) to the coolant control valve body.

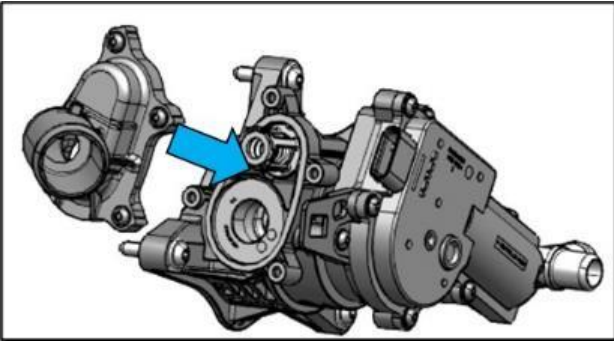

a. Ensure that the thermostat cover gasket is inserted correctly in thermostat cover slot.



b. Place each of the marked four (4) screws in their respective holes and tighten them by hand. If resistance is felt, unscrew once, and repeat the procedure.

**NOTE:**

- If screws are not inserted in their original holes, holes may become deformed.
- Do not use lubricants, spray lube, silicone sealer or petroleum grease on any of the gaskets.

c. Tighten the screws in a criss-cross pattern.

**Tightening torque:** Tighten screws to 26 in. lbs (3 Nm), then repeat tightening to 44 in. lbs (5 Nm).

**CAUTION:** Use hand tools only, do not use power tools.

**CONSUMER NOTICE:** The information and instructions in this bulletin are intended for use by skilled technicians. Mazda technicians utilize the proper tools/ equipment and take training to correctly and safely maintain Mazda vehicles. These instructions should not be performed by "do-it-yourselfers." Customers should not assume this bulletin applies to their vehicle or that their vehicle will develop the described concern. To determine if the information applies, customers should contact their nearest authorized Mazda dealership. Mazda North American Operations reserves the right to alter the specifications and contents of this bulletin without obligation or advance notice. All rights reserved. No part of this bulletin may be reproduced in any form or by any means, electronic or mechanical--including photocopying and recording and the use of any kind of information storage and retrieval system ---without permission in writing.

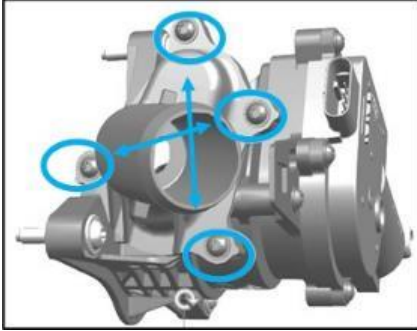

6. Reinstall the coolant control valve and the new water outlet gasket (included in the thermostat set) to the vehicle according to the instruction on MGSS.

7. Verify the repair by inspecting for engine coolant leakage.

## PARTS INFORMATION

Parts Number	Description	Qty.	Notes
PYY2-15-SA1	THERMOSTAT SET	1	---
PYFB-15-169	GASKET,WATER OUTLET	1	[R] for Lower radiator hose component
PE13-15-296	CONNECTOR	1	[R] for water hose for A/T oil cooler
0000-77-508F-20	COOLANT	---	7.4 L {7.8 US qt, 6.5 Imp qt} maximum

[R]: Replacement parts

## WARRANTY INFORMATION

### NOTE:

- This warranty information applies only to verified customer complaints on vehicles eligible for warranty repair.
- Additional diagnostic time cannot be claimed for this repair.
- This repair will be covered under Mazda's Powertrain Warranty:

U.S.A. except 2018 MAZDA6, 2019/2020/2022 CX-3 and 2018 CX-5:  
Calif. Emission Warranty (long term)

U.S.A. 2018 MAZDA6, 2019/2020 CX-3 and 2018 CX-5:  
Calif. Emission Warranty (short term)

Warranty Type Code	A
Symptom Code	6X
Damage Code	9K
Causal Part No.	PYY2-15-SA1

**CONSUMER NOTICE:** The information and instructions in this bulletin are intended for use by skilled technicians. Mazda technicians utilize the proper tools/ equipment and take training to correctly and safely maintain Mazda vehicles. These instructions should not be performed by "do-it-yourselfers." Customers should not assume this bulletin applies to their vehicle or that their vehicle will develop the described concern. To determine if the information applies, customers should contact their nearest authorized Mazda dealership. Mazda North American Operations reserves the right to alter the specifications and contents of this bulletin without obligation or advance notice. All rights reserved. No part of this bulletin may be reproduced in any form or by any means, electronic or mechanical--including photocopying and recording and the use of any kind of information storage and retrieval system ---without permission in writing.

Quantity	1
Operation No. and Labor Hours	Refer to the table below

Model	Engine	Variation	Operation No	Labor Hours (hrs.)
Mazda3	PE	---	XXWPDARX	1.5
	PY			
2020-2023 CX-30	PE	MT with radiator A type	XXWPDARX	1.4
		MT with radiator B type	XXWPDARX	1.5
		AT		
	PY	AT		
2024 CX-30	PE	---	XXWPDARX	1.5
	PY			
CX-3	PE			
CX-5	PE	MT	XXWPDARX	1.5
		AT	XXWPDCRX	1.6
	PY	AT		
Mazda6	PE	---	XXWPDCRX	1.6
	PY			

**CONSUMER NOTICE:** The information and instructions in this bulletin are intended for use by skilled technicians. Mazda technicians utilize the proper tools/ equipment and take training to correctly and safely maintain Mazda vehicles. These instructions should not be performed by "do-it-yourselfers." Customers should not assume this bulletin applies to their vehicle or that their vehicle will develop the described concern. To determine if the information applies, customers should contact their nearest authorized Mazda dealership. Mazda North American Operations reserves the right to alter the specifications and contents of this bulletin without obligation or advance notice. All rights reserved. No part of this bulletin may be reproduced in any form or by any means, electronic or mechanical--including photocopying and recording and the use of any kind of information storage and retrieval system ---without permission in writing.