



Vermeer MV Solutions, Inc.

Trenchless
Piedmont, South Carolina 29673 USA

FIELD CAMPAIGN SERVICE BULLETIN #: SMV2024-014

DATE:

25 June 2024

CAMPAIGN TYPE:

**Mandatory – Product Safety
DEALER INSTALLATION ONLY**

CAMPAIGN CATEGORY:

Kit and Bulletin

MACHINE/ ATTACHMENT MODEL(S):	SERIAL NUMBERS:		Kit Version
	Included	Excluded	
HTV373PTO	See attached listing on page 5 of this bulletin for specific truck VIN, and MV Solution model and VIN	None	VMV01
HTV873PTO	See attached listing on page 5 - 6 of this bulletin for specific truck VIN, and MV Solution model and VIN		
JTV873PTO	See attached listing on page 6 of this bulletin for specific truck VIN, and MV Solution model and VIN		

Subject:



**Remote Grease Line
Installation and Manual
Update Kit**

(VMV000064)

Background:

MAINTENANCE PERSONNEL MUST WORK UNDER LIFTED LOAD

Some machines were not equipped with a debris tank support device. Maintenance personnel must work under raised debris tank in order to grease debris tank lift mechanism.

DEATH OR SERIOUS INJURY

If the debris tank were to lower unexpectedly while greasing the debris tank lift mechanism, the maintenance person performing that work could be crushed.

Solution:

IMMEDIATE MACHINE MODIFICATIONS REQUIRED

VMV000064 has been created to provide the necessary parts and instructions to add remote grease lines and updated operator's manual. The remote grease system eliminates the need to work under the lifted load. If equipped, existing debris tank support devices are no longer required for greasing the debris tank lift mechanism. **This kit must be installed as soon as possible.**

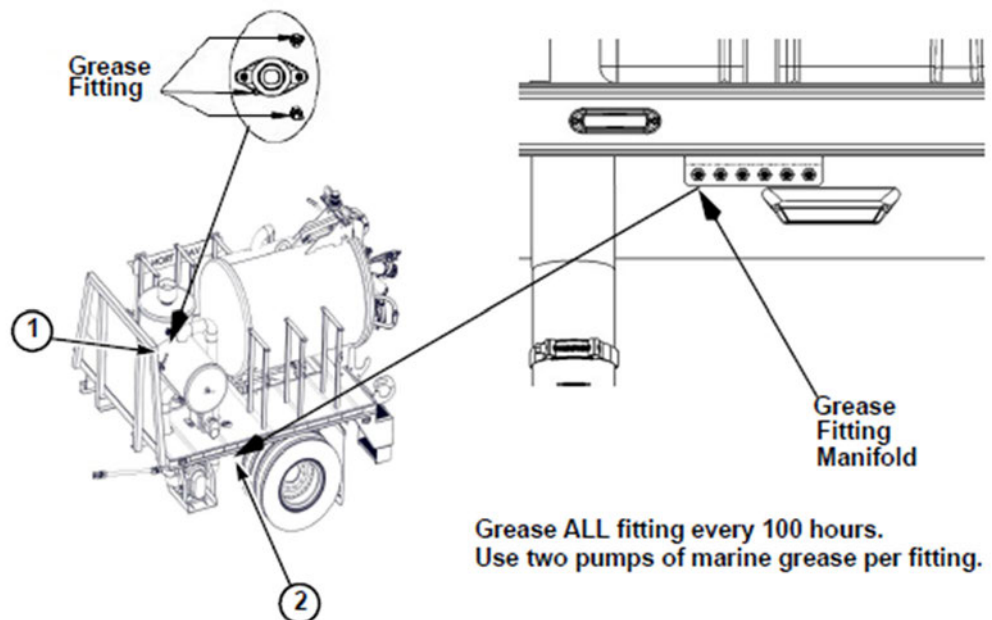

Vermeer Corporation is administering this product safety alert on behalf of Vermeer MV Solutions, Inc.

DEALER PARTICIPATION REVIEW REPORT, ORDER KITS, CONTACT CUSTOMERS

1. **Reports will be emailed** during the week of June 25, 2024, to dealerships shown in our records which have units in their territory affected by this alert. Please review the report for accuracy, including owner and/or address changes.

If the information contained in the report is **not** correct, please notify the product safety department on or before July 8, 2024, at:

Telephone: 641-621-7060
Fax: 641-621-8562
Email: productsafety@vermeer.com

2. **Dealership orders kits** by entering the order into EzParts. Each dealership should determine the quantity of kits to order initially depending upon the number of units that may be available for immediate upgrade. **Do not order more kits than needed for immediate installation.**
3. **Contact your affected customer(s)** to schedule a mutually acceptable time to upgrade their machine(s). **Note:** Letters will be sent to the customer(s) on or about **July 9, 2024**. *Also refer to Owner Notification section below.*

If you have any questions concerning the installation of VMV000064, please contact Vermeer MV Solutions service department at 888-822-8766 (Florida).

REIMBURSEMENT

Upon completion of each kit installation, a campaign warranty claim must be submitted to the warranty department for reimbursement of the cost of parts and labor to install the kit. Labor hours to install: 8 hours.

Travel will be paid up to \$200 (\$1 per mile with a \$200 ax round trip) with copy of work order attached for retailed machines not in dealer inventory. If dealer repairs more than one machine at same location on one trip, travel will only be paid on one of the model/VINs.

Note: *Future notices to dealers and owners are dependent upon the receipt of warranty claims.*

OWNER NOTIFICATION

Sample letter: Included at the end of this bulletin is a sample letter which will be sent by Vermeer Corporation on behalf of Vermeer MV Solutions directly to the owners on or about **July 9, 2024**, via USPS certified/registered mail. Owner registrations indicate no translations are required for this campaign. The owner letter will only be available in English.

This owner notification/letter instructs the owner **to contact their local dealership** to arrange for a time to have the kit installed. After receiving VMV000064 from Vermeer MV Solutions, you must **contact your affected customer(s) immediately** and schedule a mutually acceptable time to upgrade their machine(s).

We regret any inconvenience that these corrective measures may cause you. The required work is for the safety of maintenance personnel or others greasing the debris tank lift mechanism.

VERMEER MV SOLUTIONS, INC.

Attachment:
VMV000064 Kit Instructions

Completion schedule: <input checked="" type="checkbox"/> Product Safety Alert: Install immediately <input type="checkbox"/> 90 days from MM/DD/YYYY <input type="checkbox"/> 180 days from MM/DD/YYYY <input type="checkbox"/> 1 year from MM/DD/YYYY <input type="checkbox"/> Only units within standard limited warranty period <input type="checkbox"/> N/A	Reimbursement: <input checked="" type="checkbox"/> Product Safety Alert <input checked="" type="checkbox"/> All units listed above <input checked="" type="checkbox"/> Parts <input checked="" type="checkbox"/> Labor paid (Labor code: SB24) <input type="checkbox"/> Only units within standard limited warranty period <input type="checkbox"/> No reimbursement
---	--

Internal reference:	<input checked="" type="checkbox"/>	--	Not applicable	<input type="checkbox"/>	12	Exterior lighting
TREAD Act Code <i>(Choose one or more applicable codes)</i>	<input type="checkbox"/>	02	Suspension	<input type="checkbox"/>	16	Structure
	<input type="checkbox"/>	03	Service brake system, hydraulic	<input type="checkbox"/>	17	Latch
	<input type="checkbox"/>	04	Service brake system, air	<input type="checkbox"/>	19	Tires
	<input type="checkbox"/>	05	Parking brake	<input type="checkbox"/>	20	Wheels
	<input type="checkbox"/>	11	Electrical	<input type="checkbox"/>	21	Trailer hitch



SAMPLE
OWNER
LETTER



PRODUCT SAFETY ALERT

First Notice

Remote Grease Line Installation and Manual Update Kit (VMV000064)

VERMEER MV SOLUTIONS, INC.
Administered by:
Product Safety Department
Vermeer Corporation
1210 Vermeer Rd East
Pella, Iowa 50219 USA
productsafety@vermeer.com

July 9, 2024

Dear «MODEL» owner:

Model: «Model»

MV Solutions PIN: «SerialN»

Truck VIN: «SerialN»

According to our records, you currently own a Vermeer «MODEL» vacuum excavator. The model and serial number are shown at the top right of this letter.

MAINTENANCE PERSONNEL MUST WORK UNDER LIFTED LOAD

Some machines were not equipped with a debris tank support device. Maintenance personnel must work under raised debris tank in order to grease debris tank lift mechanism.

DEATH OR SERIOUS INJURY POSSIBLE

If the debris tank were to lower unexpectedly while greasing the debris tank lift mechanism, the maintenance person performing that work could be crushed.

IMMEDIATE MACHINE MODIFICATIONS REQUIRED

VMV000064 has been created to provide the necessary parts and instructions to add remote grease lines and updated operator's manual. The remote grease system eliminates the need to work under the lifted load. If equipped, existing debris tank support devices are no longer required for greasing the debris tank lift mechanism. **This kit must be installed as soon as possible.**

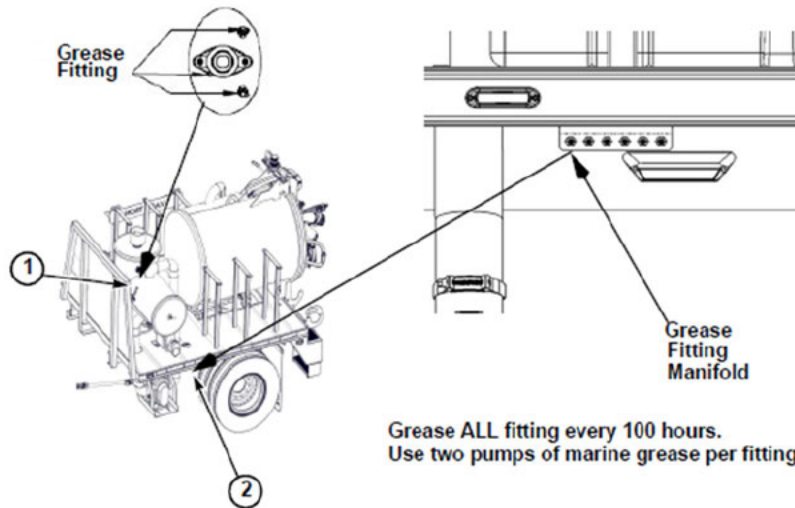

Please contact your authorized, independent Vermeer dealer immediately to arrange a mutually acceptable time and location to install VMV000064 at no cost to you for labor or materials. If the Vermeer dealer travels to the unit to install the kit, costs may be incurred by the owner. **You must have your machine upgraded for these safety features.**

Contact your local Vermeer dealer:	«Service_Dealer_Name» «Serv_Dealer_Add1» «Serv_Dealer_Add2» «Serv_Dealer_City» «Serv_Dealer_St» «Serv_Dealer_Zip» «SERV_DEALER_COUNTRY»
Telephone:	«Serv_Dealer_Phone»

If you no longer own this unit, please notify the product safety department at:

Toll-free: 800-829-0051, option 1
Telephone: 641-621-7060
Email: productsafety@vermeer.com

If possible, please provide the name and address of the new owner.

We regret any inconvenience that these corrective measures may cause you. The required work is for the safety of maintenance personnel or others greasing the debris tank lift mechanism.

Regards,
Vermeer MV Solutions, Inc.