

LED Tail Light With Light Panel, Dark-Tinted (8VQ)

Change overview:

Release	Date	Change
0	08/02/2022	• First publication
1	06/28/2024	• Addition of step 6.1.4.

Restrictions: **ONLY** approved for vehicles with virtual pedal (4E6) and/or Comfort Access (4F2)!

Model Year: **As of 2021**

Information: **Retrofitting**



Figure 1

Notes: In vehicles with a standard LED tail light (8VG), a dark-tinted LED tail light or Exclusive Design tail light (8VQ ⇒ *Figure 1*) can be retrofitted.

For this purpose, it is necessary to route control lines (LIN bus), to replace the tail lights and then to code the new functions.

The design and shape of the new tail lights correspond to those of the standard lights. The differentiated look contains:

- Arc without red components
- Specific design of the side vents
- Specific Coming/Leaving Home function

- Functions:
- Animation runs from the outside to the interior for approx. 0.7 seconds.
 - Animation only runs when the vehicle detects a certain darkness and the vehicle is stationary.
 - When the animation intervenes 4 times in succession, so-called "play prevention" prevents the other animations. The function (reset) is reset by switching the vehicle ignition on again.
 - "Automatic Coming/Leave Home = Home lights" function corresponds to the standard lighting.

Parts Info: **971.044.942** ⇒ LED tail light with light strip, dark-tinted –SAE–, set

Always order at the same time:

9A7.007.942.00 2 x ⇒ Locking pin luggage compartment cover

Parts List:

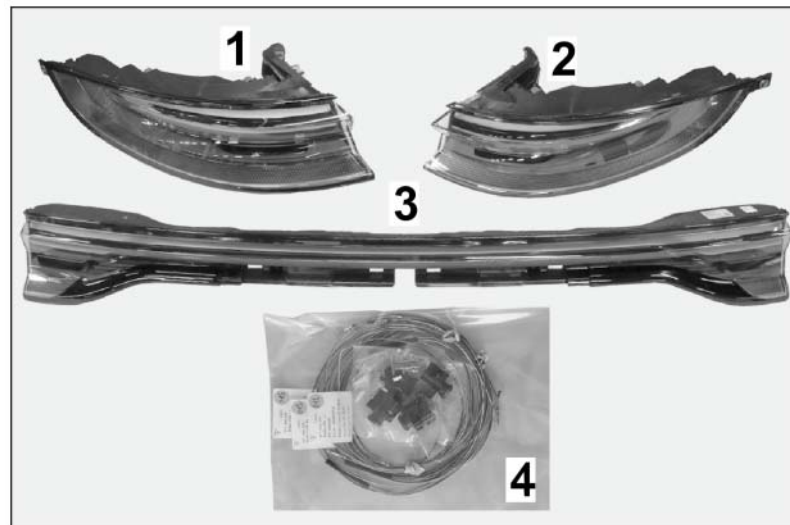

Figure 2

973.945.095.AM ¹	1 x	Tail light, left SAE (not shown)
973.945.096.AM ¹	1 x	Tail light, right SAE (not shown)
973.945.093.BC ²	1 x	Tail light in tailgate - SAE (not shown)
971.044.939	1 x	Electrical system scope ⇒ <i>Figure 2-4-</i>
N 911.585.01	6 x	Expansion rivet, B6.5 x 12.3 (not shown)

1 **ONLY** contained in set 971.044.942.

2 **ONLY** contained in respective set.

Spare part:

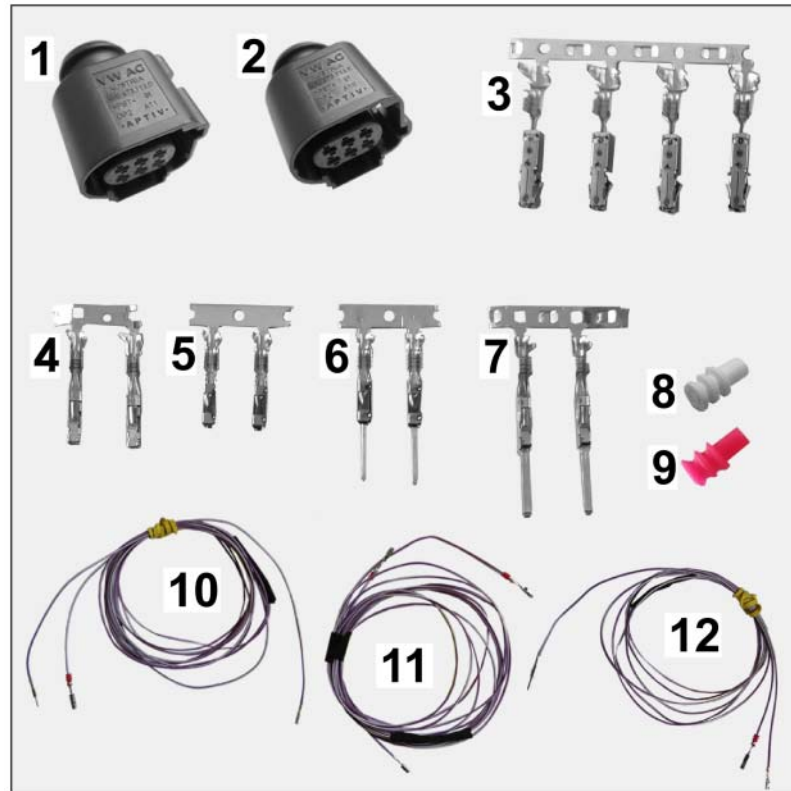

Figure 3

Electrical system components (971.044.939), consisting of:

----	1 x	Connector, 6-pin (4H0.973.713.D – light panel, right) ⇒ Figure 3-1-
----	3 x	Connector, 6-pin (4H0.973.713.E) ⇒ Figure 3-2-
N .105.112.03	4 x	Flat contact 1.5 ⇒ Figure 3-3-
----	2 x	Sleeve/bush, length 16 mm/ 0.63 in ⇒ Figure 3-4-
----	2 x	Sleeve/bush, length 14 mm/ 0.55 in ⇒ Figure 3-5-
----	2 x	Pin, length 16 mm/ 0.63 in ⇒ Figure 3-6-
----	2 x	Pin, length 22 ⇒ Figure 3-7-
----	5 x	Dummy plug, white ⇒ Figure 3-8-
958.612.740.00	4 x	Seal on individual wire, red ⇒ Figure 3-9-
----	1 x	Wire harness for module FGR_le ⇒ Figure 3-10-
----	1 x	Wire harness for module HKL_le ⇒ Figure 3-11-
----	1 x	Wire harness for module FGR_ri ⇒ Figure 3-12-

Materials:	000.043.172.00	1 x	Sealing cord (butyl)
	----	1 x	Wrapping/insulating tape (commercially available)
	----	1 x	Cleaning cloth (commercially available)
	----	1 x	Isopropanol (commercially available)
	----	1 x	Insulating hose for PVC/ insulation tube, Ø approx. 5 mm (0.2 in)/ length approx. 10 m (32.8 ft) (commercially available)

Tool: **P90999 - PIWIS Tester 4**

Flashlight

Auxiliary line (Tekalan/ Teflon hose) or plastic rail (transport protection for windscreen) approx. 1,000 mm/ 3.28 ft long

Assembly:

1 Preliminary work

- 1.1 Drive the vehicle onto the lifting platform. ⇒ *Workshop Manual '4X00IN Lifting the vehicle'*
- 1.2 Connect a battery charger. ⇒ *Workshop Manual '2X00IN Battery trickle charge'*
- 1.3 Uncover tailgate area
 - 1.3.1 Remove tail light in tailgate. ⇒ *Workshop Manual '943119 Removing and installing rear light on tailgate'*
 - 1.3.2 Remove trim panel for rear lid (lower, left and top). ⇒ *Workshop Manual '709219 Removing and installing trim panel for rear lid'*
 - 1 – Trim panel for window frame (right)
 - 2 – Grommet at connection point for tailgate (left)
 - 3 – Branch for wire harness and grommet (tailgate tail light)
- 1.4 Expose rear of vehicle outer area
 - 1.4.1 Remove rear apron. ⇒ *Workshop Manual '635519 Removing and installing rear bumper'*
 - 1.4.2 Remove tail light at the left/right. ⇒ *Workshop Manual '943119 Removing and installing rear light'*
- 1.5 Expose –center– luggage compartment area

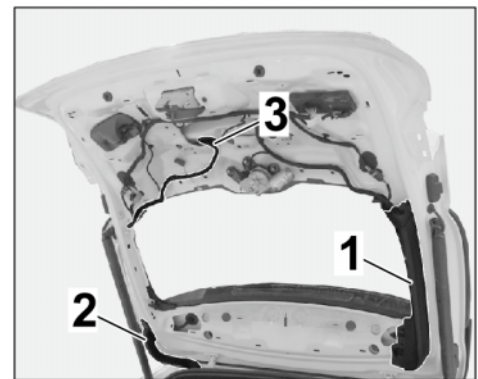

Figure 4 (Sport Turismo)

- 1.5.1 Remove (center) luggage compartment trim panel luggage compartment cover. ⇒ *Workshop Manual '700619 Removing and installing (side) luggage compartment trim panel luggage compartment cover'*
- 1.5.2 Removing cover for rear lock carrier. ⇒ *Workshop Manual '703919 Removing and installing cover for rear lock carrier'*
- 1.5.3 Remove (side) luggage compartment trim panel luggage compartment cover. ⇒ *Workshop Manual '700619 Removing and installing (side) luggage compartment trim panel'*
- 1.6 Expose luggage compartment area –left/right–
 - 1.6.1 Remove rear luggage compartment side trim panel. ⇒ *Workshop Manual '700319 Removing and installing side trim panel for rear luggage compartment'*
 - 1.6.2 Remove C-pillar trim panel (upper part). ⇒ *Workshop Manual '706819 Removing and installing C-pillar trim panel (upper part)'*
 - 1.6.3 Remove D-pillar trim panel. ⇒ *Workshop Manual '706919 Removing and installing D-pillar trim panel'*

Remove (left) D-pillar holder.
⇒ *Figure 5 (Sport Turismo)*

- 1 – D-pillar holder (left)
- 2 – BOSE® Subwoofer

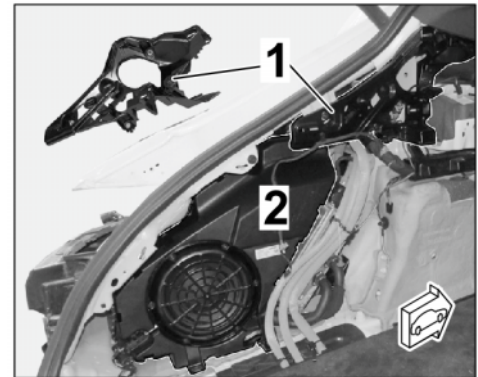

Figure 5 (Sport Turismo)

- 1.6.4 **ONLY** for vehicles with BOSE® Surround Sound System (9VL): ⇒ *Figure 5 (Sport Turismo)-2-* Remove subwoofer. ⇒ *Workshop Manual '913619 Removing and installing subwoofer'*

- 1.6.5 **ONLY** for vehicles with electric compressor (1G8): ⇒ *Figure 6 (Hybrid)*
Remove tire sealant and compressor.

- 1 – tire sealant
- 2 – Compressor
- 3 – Retaining bar for vehicle electrical system battery

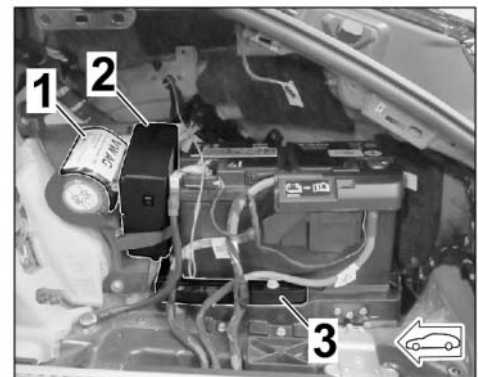

Figure 6 (Hybrid)

- 1.6.6 Remove retaining bar for vehicle electrical system battery (⇒ *Figure 6 (Hybrid)-3-*) and unclip lines

(positive and negative). ⇒ *Workshop Manual '270619 Removing and installing vehicle electrical system battery'*

Park vehicle electrical system battery with lines connected as far as possible in the center luggage compartment area.

- 1.6.7 Remove luggage compartment trim panel (luggage compartment cover) at the lock carrier. ⇒ *Workshop Manual '700619 Removing and installing luggage compartment trim panel (luggage compartment cover) at the lock carrier'*

2 Routing and connecting electric wire harnesses

Overview of routing of wire harnesses ⇒ *Figure 7*

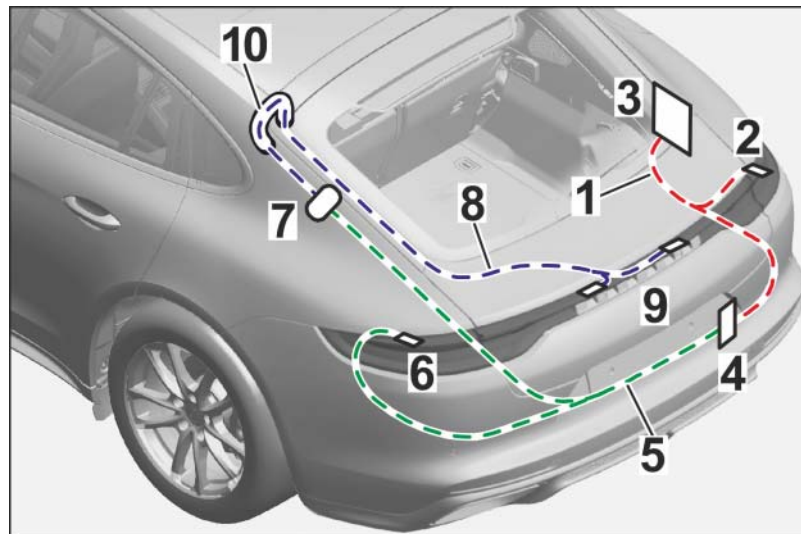

Figure 7

- 1 – Wire harness for module FGR_ri
- 2 – Tail light (right)
- 3 – Rear-end electronics control unit - BCM2
- 4 – Rear cross-over connection point
- 5 – Wire harness for module FGR_le
- 6 – Tail light (left)
- 7 – C-pillar connection point (left)
- 8 – Wire harness for module HKL_le
- 9 – Tail light to tailgate
- 10 – Grommet on tailgate hinge (left)

NOTICE

Incorrect line routing

- Risk of damage to lines and hoses
- Malfunction and fault memory entry on control unit

- ⇒ Avoid small bending radii when routing lines.
- ⇒ File down edges and burrs in the routing area or mask them with adhesive tape.
- ⇒ Maintain a sufficient distance from components exposed to high temperatures while driving.

BEFORE routing wire harnesses, wrap insulating tape around them if necessary or protect PVC/insulated tube Ø approx. 5 mm/ 0.2 in from damage.

2.1 Route and connect wire harness for module FGR_ri

Overview of routing of wire harness for module FGR_ri: ⇒ *Figure 8*

- 1 – Wire harness for module FGR_ri
- 2 – Grommet for tail light (right)
- 3 – BCM2; connector C (black); chamber 5
- 4 – Rear cross-over connection point / brown connector, chamber 12

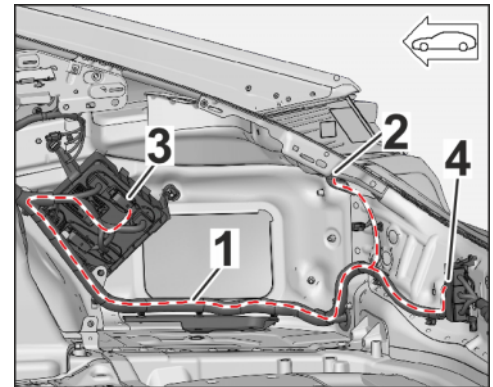

Figure 8

2.1.1 Tail light area, right (see also wiring diagram 12.2 – Vehicle exterior lighting, sheet 2) ⇒ *Figure 9*

- 1 – Grommet
- 2 – Wire harness for tail light
- 3 – Line VT/WH; 0.5² (LIN)
- 4 – New connector housing (6-pin; 4H0.973.713.E)
- 5 – New sealing compound



Information

Observe markings on the housing!

- Remove branch (wire harness) for tail light with grommet (⇒ *Figure 8-2-*).
- Guide branch with connector (6-pin) into the luggage compartment.
- Carefully loosen the installed grommet on the branch (wire harness) and slide it towards the connector (6-pin). ⇒ *Figure 9-Top, arrow-*

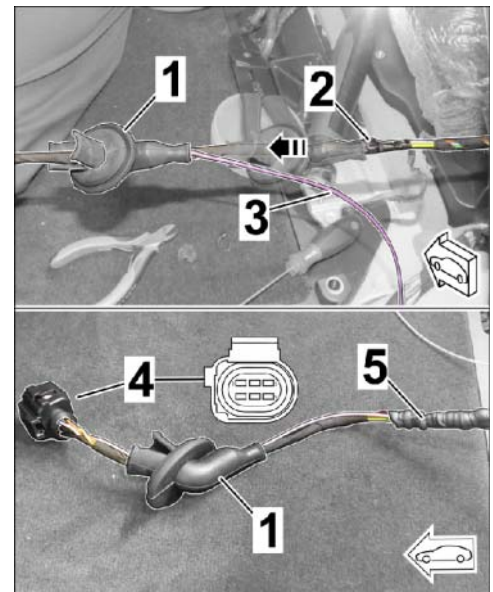

Figure 9

- Carefully feed line VT/WH 0.5² with single-wire seal (connection for wire harness for module FGR_re) through the grommet and guide it to the connector (6-pin).
- Open the connector (6-pin) and change the lead in the **NEW** connector housing (6-pin, 4H0.973.713.E) at the same position.
- Insert socket contact (VT/WH 0.5² line with single-wire seal) into chamber 3.
- Close off chambers **WITHOUT** using dummy plug (white) configuration.

Connector (6-pin) 4H0.973.713.E	Function
	SAE
Chamber 1 – BN; 0.5 ²	Weight
Chamber 2 – GY; 0.5 ²	Brake light and & direction indicator light
Chamber 3 – VT/WH; 0.5 ²	LIN = Control animation
Chamber 4 – BK/RD; 0.5 ²	Power supply, terminal 30G
Chamber 5 – YE/GN, 0.5 ²	Dummy plug (white)
Chamber 6	Dummy plug (white)

- Carefully install grommet with some sealing compound at the old position (⇒ *Figure 9-5-*).
- Guide connector (6-pin) with connection (wire harness for tail light) from luggage compartment to the outside.
- Install grommet in the body. Check that the grommet is seated correctly in the body.

2.1.2 Rear-end control unit BCM2 area
(see also wiring diagram 02_1
– Rear-end electronics, sheet 1)
⇒ *Figure 10*

- 1 – Connector (32-pin, black)
- 2 – Rear-end electronics control unit BCM2
- 3 – Connector housing, chamber 5



Information

Observe markings on the housing!

- Route branch for BCM2 to BCM2. ⇒ *Figure 8-3-*
- Remove connector C (black) from BCM2 and open it. ⇒ *Figure 10-2-*
- Check that chamber 5 already has a VT/WH 0.5² line (line 53003 Virtual pedal.)
- **YES:** Double connector on existing line.
- **NO:** Insert VT/WH 0.5² line with pin contact into chamber 5.
- Close connector C (black) and install in BCM2.

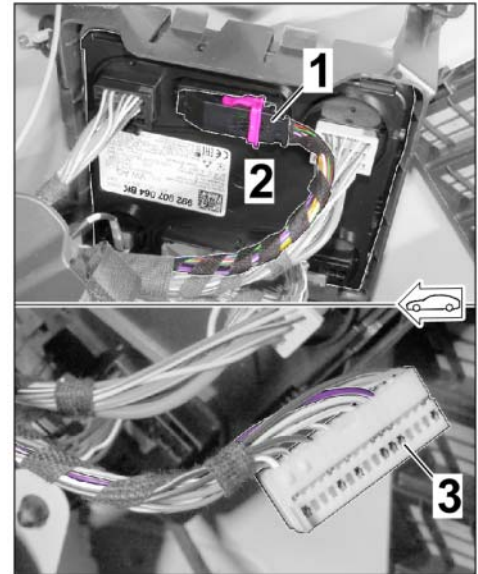

Figure 10

2.1.3 Rear cross-over connection point area ⇒ *Figure 11*

- 1 – Wire harness for module FGR_ri
- 2 – Rear cross-over connection point
- 3 – Wire harness for module FGR_le



Information

Observe markings on the housing!

- Route branch for left rear light/tail light in tailgate to the rear cross-over connection point. ⇒ *Figure 11*
- Remove connector, 17-pin (brown) from holder and release it.
- Insert VT/WH 0.5² line with socket contact into chamber 12. ⇒ *Figure 13-1-*
- Lock connector, 17-pin (brown) and install it in the holder.

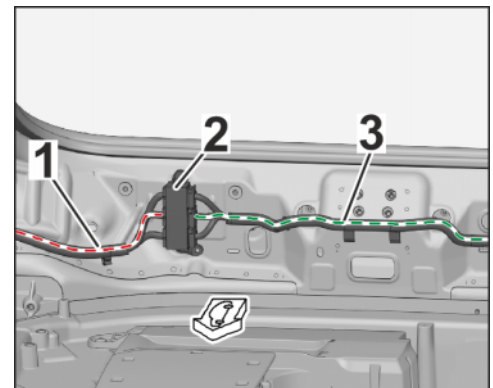

Figure 11

2.2 Route and connect wire harness for FGR_le module

2.2.1 Tail light area, left (see also wiring diagram 12.2 – Vehicle exterior lighting, sheet 2) ⇒ *Figure 12*

- 1 – Wire harness for module FGR_le
- 2 – Grommet for tail light (left)
- 3 – Branch at connection point for tailgate, left (C-pillar)

- Repeat Step 2.1.1 for the left tail light. ⇒ *Figure 12-2-*

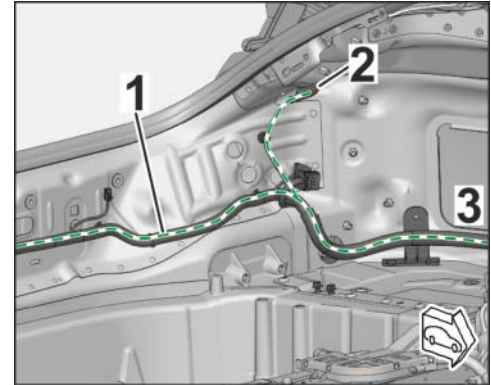
*Figure 12*2.2.2 Rear cross-over connection point area ⇒ *Figure 13*

- 1 – Plug socket, 17-pin (brown), chamber 12
- 2 – Pin connector socket, 17-pin (brown), chamber 12
- 3 – Unlocking / Locking

- Route branch with pin contact along the wire harness to the rear cross-over connection point.
- Repeat Step 2.1.3 for connector, 6-pin (brown) – left side (in direction of travel) for VT/WH; 0.5² line with pin contact. ⇒ *Figure 13-2-*

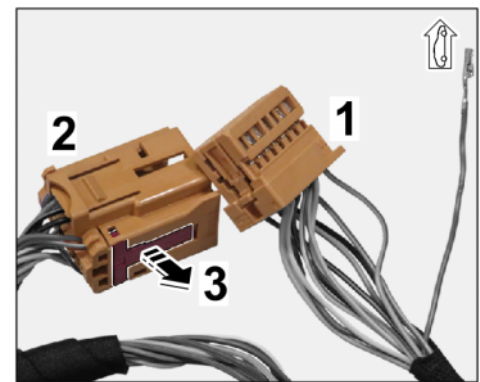
*Figure 13*

2.2.3 Rear lid connection point area, left C-pillar (see also wiring diagram 45A – left rear cap) ⇒ *Figure 14*

- 1 – Wire harness for module FGR_le
- 2 – Rear lid connection point (left C-pillar)
- 3 – Wire harness for module HKL_le
- 4 – Grommet on rear lid, left

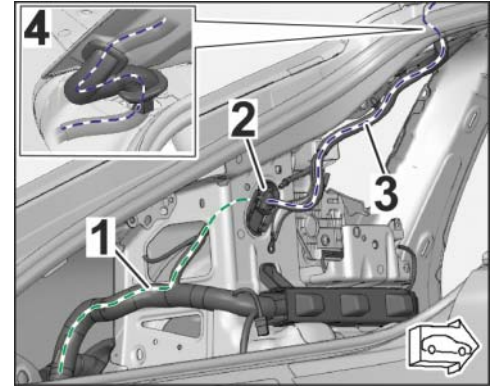

Figure 14

- Route branch with pin contact along the wire harness to the connection point on the rear lid (left C-pillar).

Disconnect plug connections, 17-pin (black and brown) and remove plug connections holder from the C-pillar if necessary. ⇒ *Figure 15*

- 1 – Connector, 17-pin (black)
- 2 – Connector, 17-pin (brown)
- 3 – Plug connection holders
- 4 – Pin connector socket, 17-pin (black)

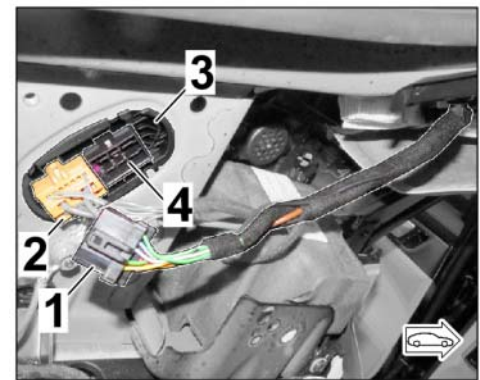

Figure 15

- Remove pin connector socket, 17-pin (black) on the back from the holder and release it.
- Insert VT/WH 0.5² line with pin contact into chamber 8.
- Lock pin connector socket, 17-pin (black) and install on the back of the holder.

2.3 Route and connect wire harness for module HKL_le

Overview of routing of wire harness for module HKL_le: ⇒ *Figure 14* and ⇒ *Figure 16*

- 1 – Wire harness for module HKL_le
- 2 – Grommet on tailgate hinge (left)
- 3 – Grommet rear light tailgate
- 4 – New connector, left (6-pin, 4H0.973.713.E)
- 5 – New connector, right (6-pin, 4H0.973.713.D)

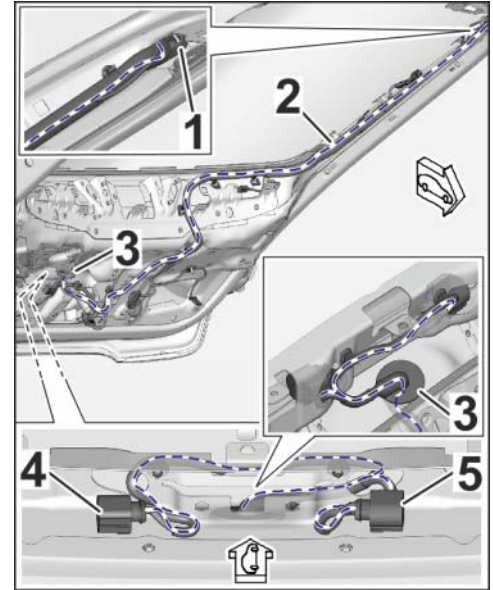

Figure 16

2.3.1 Tail light in tailgate area (see also wiring diagram 45A – Tailgate, left) ⇒ *Figure 17 (Sport Turismo)*

- 1 – New connector, right (6-pin, 4H0.973.713.D)
 - 2 – New connector, left (6-pin, 4H0.973.713.E)
 - 3 – Grommet rear light tailgate
- Arrows** – Coding connectors, left/right

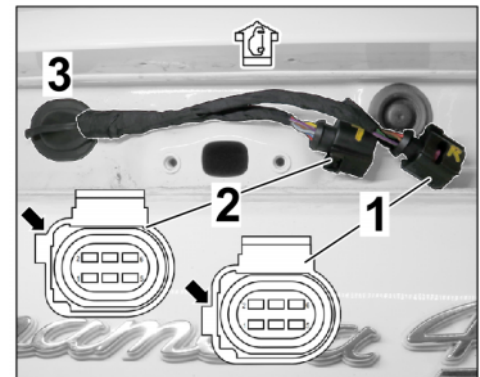

Figure 17 (Sport Turismo)

**Information**

Observe markings on the housing!

- Open connectors (6-pin) on the left and right side.
- Connect existing lines to **NEW** connector housing, 6-pin (**left:** 4H0.973.713.E / **right:** 4H0.973.713.D) at the same position.
- Insert socket contact (VT/WH 0.5² line with single-wire seal) into chamber 3.
- Close off chambers **WITHOUT** using dummy plug (white) configuration.
- Lock connectors (6-pin) on the left and right side. ⇒ *Figure 17 (Sport Turismo)*
- Function test: Connect plug connection (6-pin, left and right) for the new tail light in the rear lid and loosen it again.

2.3.2 Tail light grommet area in tailgate ⇒ *Figure 16-3-* and ⇒ *Figure 17 (Sport Turismo)*
-3-

- Disconnect wire harness for tailgate tail light on the tailgate and remove grommet on the tailgate.
- Remove grommet on wire harness in the same way as for grommets on tail lights (move them).
- Carefully guide branch for wire harness for module HKL_1e, with socket contact for connection point for left C-pillar, through the grommet in the tailgate.
- Carefully install grommet with some sealing compound at the old position.
- Install grommet on the rear lid. Check that the grommet is seated correctly.

2.3.3 Inner tailgate area

- 1** – Grommet rear light tailgate
- 2** – Line VT/WH; 0.5²
- 3** – Grommet on tailgate hinge (left)
- 4** – Rear window wiper
- A** – Sport Turismo
- B** – Basic/Executive

- Route VT/WH 0.5² line (socket contact) along the existing line to the left side of the rear window frame. Sport Turismo: ⇒ *Figure 18-A-*
- Route VT/WH 0.5² line further along the left rear window frame to the grommet on the (left) tailgate hinge. ⇒ *Figure 18-B-*

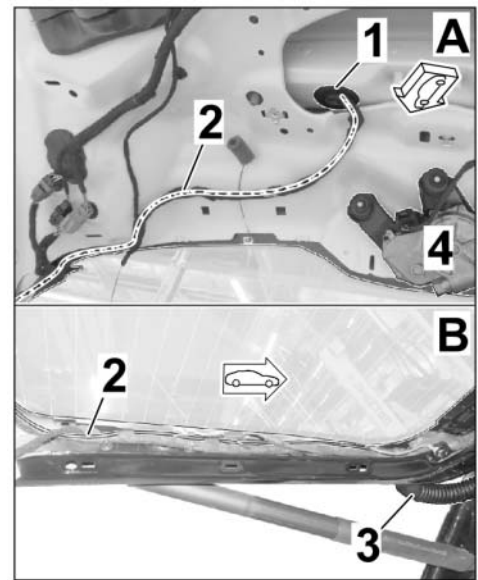

Figure 18

2.3.4 Grommet in area of left tailgate hinge ⇒ *Figure 19*

- 1 – Grommet on tailgate hinge (left)
- 2 – Piping (e.g. plastic rail)
- 3 – Line VT/WH; 0,5² with socket contact

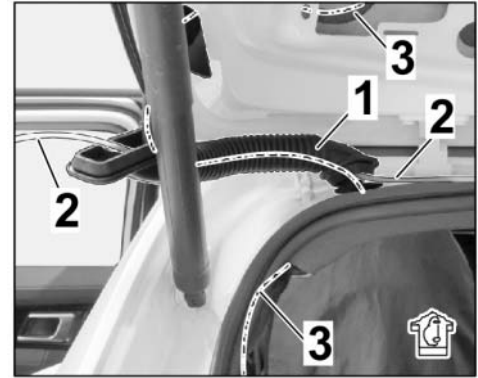

Figure 19

- Loosen sleeve on (left) tailgate hinge from the body/rear lid.
- Carefully guide socket contact and line VT/WH 0.5² through the grommet using a piping (e.g. plastic rail from transport protection for windscreen).
- Install grommet on (left) tailgate hinge in the body/rear lid. Check that the grommet is seated correctly.

2.3.5 Rear lid connection point, left C-pillar (see also wiring diagram 45A – left rear cap) ⇒ *Figure 14* and ⇒ *Figure 15*

- Remove plug socket, 17-pin (black) on the front of the holder and release it.
- Insert VT/WH 0.5² line with pin contact into chamber 8.
- Lock plug socket, 17-pin (black) and install it on the front of the holder.
- Connect plug connections, 17-pin (black and brown) and install plug connections holder in C-pillar.

- 2.4 Secure routed wire harness to existing lines/components in the vehicle with tie-wraps without tensile stress and so that no chafing occurs.

3 Concluding work

3.1 Complete luggage compartment area –left/right–

- 3.1.1 Perform installation in reverse order to removal.

- 3.1.2 After installing the D-pillar trim panel, install **NEW** locking pins for the luggage compartment cover. ⇒ *Workshop Manual '706919 Removing and installing D-pillar trim panel'*

Tightening torque 12.5 Nm (9.2 ftlb.)

3.2 Complete the –center– luggage compartment area

Perform installation in reverse order to removal.

3.3 Completing outer vehicle check

- 3.3.1 Install new tail light at the left/right. ⇒ *Workshop Manual '943119 Removing and installing rear light'*

3.3.2 Install rear bumper. ⇒ *Workshop Manual '635519 Removing and installing rear bumper'*

3.4 Completing tailgate area

3.4.1 Install trim panel for rear lid (lower, left and top). ⇒ *Workshop Manual '709219 Removing and installing trim panel for rear lid'*

3.4.2 Install tail light in tailgate. ⇒ *Workshop Manual '943119 Removing and installing rear light on tailgate'*

Coding: 4 Enter LED tail lights (8VQ) in the vehicle data

NOTICE

Voltage drop

- Risk of irreparable damage to control unit
 - Risk of damage to control unit
 - Fault entries in the control unit
 - Coding in the control unit is aborted
 - Malfunctions in control unit, even during programming
- ⇒ Switch off the ignition and remove the ignition key before disconnecting the control unit.
- ⇒ Ensure that the power supply is not interrupted during programming.
- ⇒ Connect a battery charger with a current rating of at least Nominal value 90 A to the vehicle battery.

4.1 Preparatory work – Coding

NOTICE

Control unit programming will be aborted if the Internet connection is unstable.

- An unstable Internet connection can interrupt communication between PIWIS Tester 4 and the vehicle communication module (VCI). As a result, control unit programming may be aborted.
- ⇒ During control unit programming, always connect PIWIS Tester 4 to the vehicle communication module (VCI) via the USB cable.

4.1.1 **P90999 - PIWIS Tester 4** must be connected to the vehicle and switched on.

4.1.2 Switch on ignition **AND** hazard warning lights on the vehicle.

**Information**

The **P90999 - PIWIS Tester 4** instructions take precedence since the description may be different with later Tester releases.

The procedure described here has been structured in general terms; different text or additions may appear on the **P90999 - PIWIS Tester 4**.

- 4.1.3 Select the "Diagnostics" menu item on the PIWIS Tester.
- 4.1.4 If **P90999 - PIWIS Tester 4** is connected correctly, a connection to the vehicle will be established: "971 model line" is detected.
- 4.1.5 Create a vehicle analysis log (VAL) in the "Overview" menu item.

**Information**

The function is **ONLY** available when the Tester is online!

- 4.2 Enter the new vehicle equipment in the vehicle data using "PIWIS Online"
 - 4.2.1 Select the function "Maintenance of vehicle data with PIWIS ONLINE" in the "Model line-specific tests and campaigns" menu item.

A message appears informing you that the "Actual" (vehicle) data and "Required" (PIWIS Online) data will be compared.

Press •F12" to continue.
 - 4.2.2 Confirm the message "The vehicle data was compared with PIWIS Online. Significant differences were found with •F12" .
 - 4.2.3 Look for the "SBBR lights" option in the "Family" column.

Select the relevant option "8VQ - SBBR lights animated exc VAR1" from the drop-down menu in the "Value" column. Press •F12" to continue
 - 4.2.4 A table containing the coding value and the columns "new value" and "old value" is displayed in the overview. Press •F8" to continue.
 - 4.2.5 Data is then written/stored. The following messages appear one after the other:
 - Transferring vehicle data to PIWIS Online.
 - Writing and transferring vehicle data to the vehicle.
 - Vehicle order was written successfully.
 - A check was performed in order to check whether control units have to be coded or programmed as a result of the changes that were made.
 - 4.2.6 Press •F10" to open the log. Check that the selected vehicle equipment has been entered and close the log.

- 5 Code/program the new vehicle equipment.

- 5.1 Code/program the new vehicle equipment.
 - 5.1.1 Confirm the table containing a list of control units that must be coded/programmed, by pressing •F12” .
 - 5.1.2 Individual data records will be loaded, depending on the number of control units to be coded/programmed.

Wait until messages “Creating backup documentation. Please wait ... and “Coding was completed successfully.” appear. Press •F12” to continue.

Repeat the process for other control units if necessary.
 - 5.1.3 Wait for the “Adaptation of the control units is complete.” message and check the coding status of the control units in the table displayed.

Continue by pressing •F12” to return to the control unit overview.
- 5.2 Read out the fault memory of all systems, work through any existing faults, and erase the fault memory. ⇒ *Workshop Manual 'OX03IN Diagnostic maintenance: Diagnostic system and maintenance inter...'*

Assembly:

6 Concluding work

- 6.1 Function test
 - 6.1.1 Check the functioning of the vehicle's lights. ⇒ *Workshop Manual 'OX03IN Checking the functioning of the vehicle lights'*
 - 6.1.2 Lock the vehicle and check animation in the tail lights.

Animation runs from the outside to the interior for approx. 0.7 seconds.
 - 6.1.3 Unlock the vehicle and check animation in the tail lights.

Animation runs from the outside to the interior for approx. 0.7 seconds.
 - 6.1.4 **Symptom**– Tail lights WITHOUT animation:

Using **P90999 - P90999 - PIWIS Tester 4** under the item “Coding / programming”, select the menu item “Restore factory settings / coding (or new part coding).

Continue by pressing •F12” to return to the control unit overview.

Select front electronics and carry out new part codes.

Test function again.

NOTE: When replacing the control unit for the front electronics during a repair: Check “Customer-specific settings” coding value for the “front electronics (version XYZ)” and adjust if necessary.
- 6.2 Switch off ignition and disconnect **P90999 - PIWIS Tester 4**.
- 6.3 Disconnect the battery charger. ⇒ *Workshop Manual '2X00IN Battery trickle charge'*
- 6.4 Drive the vehicle off the lifting platform.

- 94 31 24 40: –LED tail light with dark-tinted light panel (8VQ) retrofitted–
Includes: Expose (inner) tailgate and luggage compartment;
Install tail lights;
Route and connect control lines (LIN bus);
Code/program the new vehicle equipment.
Function test
ONLY for vehicles with Lane Change Assist/ Lane Keep Assist (7Y1):
Labor time: **531 TU**
- 91 70 25 50: –Program Lane Change Assist control unit–
Labor time: **56 TU**

Important Notice: Technical Bulletins issued by Porsche Cars North America, Inc. are intended only for use by professional automotive technicians who have attended Porsche service training courses. They are written to inform those technicians of conditions that may occur on some Porsche vehicles, or to provide information that could assist in the proper servicing of a vehicle. Porsche special tools may be necessary in order to perform certain operations identified in these bulletins. Use of tools and procedures other than those Porsche recommends in these bulletins may be detrimental to the safe operation of your vehicle, and may endanger the people working on it. Properly trained Porsche technicians have the equipment, tools, safety instructions, and know-how to do the job properly and safely. Part numbers listed in these bulletins are for reference only. The work procedures updated electronically in the Porsche PIWIS diagnostic and testing device take precedence and, in the event of a discrepancy, the work procedures in the PIWIS Tester are the ones that must be followed.

©2024 Porsche Cars North America, Inc.