



Technical Service Bulletin

19 Cabin heating, cooling insufficient, drive system malfunctions, DTCs P2B3000 or P2B3200 stored in 00C5

19 24 59 2073599/2 June 26, 2024. Supersedes Technical Service Bulletin Group 19 number 24-57 dated April 8, 2024 for reasons listed below.

Model(s)	Year	VIN Range	Vehicle-Specific Equipment
e-tron GT, and RS e-tron GT	2022 - 2024	All	Not Applicable

Condition

REVISION HISTORY		
Revision	Date	Purpose
2	-	Revised header (Add Model Year 2024) Revised <i>Service</i> (Part introduction dates corrected)
1	04/08/2024	Initial publication

Customer states:

The customer may have one or any combination of the following concerns:

- Cabin heating is insufficient, or no heating output.
- Cabin cooling insufficient, or no cooling output.
- Vehicle drive power is insufficient.
- The high voltage battery does not charge to full capacity.

The concern may vary depending on the customer's driving style and ambient conditions.

Workshop findings:

The following DTC or DTCs and symptom code(s) may be stored in J1024 Thermal management (address word 00C5):

- **DTC P2B3000** - Symptom 59328: Fan 1 stuck on.
- **DTC P2B3200** - Symptom 59342: Fan 2 stuck on.

Technical Background

One or both radiator fans may be blocked by debris, road dirt, or other foreign objects that enter the grille in the front wheel housing liner. This debris accumulates and mechanically blocks the cooling fan operation. This condition can occur more frequently if the vehicle is operated on unpaved roads.



Technical Service Bulletin

Production Solution

The cooling fans, shrouds and wheel housing liners have been improved in production to reduce the possibility of debris accumulation in the cooling fan mechanisms.

Service

If the customer reports only hearing noise in the front of the vehicle, none of the symptoms nor DTCs described in this TSB are present, and the cooling fans are not mechanically blocked but enough debris has entered the cooling fan mechanism to cause the noise, perform the solution specified in TSB 2073030: 19 Grinding or knocking noises from electric cooling fans when active first then reassess. Proceed with this TSB only if necessary.

Several components have been modified to prevent dirt and stones from entering the fan motor. The new components have additional, larger openings on the underside through which foreign objects can escape and a protective cap on the fan's electric motor to prevent foreign objects/dirt from getting in. If replacement of the cooling fan is necessary in this repair check the version of the wheel spoiler and wheel housing liner and replace all parts on the side being serviced with the new version components.

The chart below shows the part number progression of the components and their production implementation dates:

Component	Old version	New version	Date of introduction of new version into production
Lower wheel house protector / spoiler, right side	9J1809958B	9J1809958D	1/31/2022
Lower wheel house protector / spoiler, left side	9J1809957B	9J1809957D	1/31/2022
Radiator fan (including fan shroud), right side	9J1121205C/D	9J1121205F	5/25/2023
Radiator fan (including fan shroud), left side	9J1121203C/D	9J1121203F	5/25/2023
Protective cap, right side	9J1959725	9J1959725A	2/28/2022
Protective cap, left side	9J1959459	9J1959459A	2/28/2022
Air duct, right side	9J1121674	9J1121674A	11/15/2021
Air duct, left side	9J1121673	9J1121673A	11/15/2021

Warranty



Technical Service Bulletin

Claim Type:	<ul style="list-style-type: none"> • 110 Up to 48 Months/50,000 Miles. • G10 for CPO Covered Vehicles – Verify Owner. • If the vehicle is outside of any warranty, this Technical Service Bulletin is informational only. 		
Service Number:	1908		
Damage Code:	0040		
Labor Operations:	Front bumper cover remove and reinstall	6329 1900	See SRT with associated operations
	Cooling fan housing left – Remove and reinstall	1920 1950	See SRT with associated operations
	Cooling fan housing right – remove and reinstall	1920 1951	See SRT with associated operations
Diagnostic Time:	GFF	0150 0000	Time stated on the diagnostic protocol (Max 150 TU)
	Road test prior to the service procedure	No allowance	0 TU
	Road test after the service procedure	No allowance	0 TU
Claim Comment:	As per TSB 2073599/2		

All warranty claims submitted for payment must be in accordance with the *Audi Warranty Policies and Procedures Manual*. Claims are subject to review or audit by Audi Warranty.

Required Parts and Tools

Always check with your Parts Department and/or ETKA for the latest information and parts bulletins.		
Part Number	Part Description	Quantity



Technical Service Bulletin

9J1809958D	 <p>Lower wheel house protector / spoiler, right side</p>	1
9J1809957D	 <p>Lower wheel house protector / spoiler, left side</p>	1



Technical Service Bulletin

9J1121205F	 <p>Radiator fan (including fan shroud), right side</p>	1
9J1121203F	 <p>Radiator fan (including fan shroud), left side</p>	1



Technical Service Bulletin

9J1959725A	 <p>Protective cap, right side</p>	1
9J1959459A	<p>Protective cap, left side</p>	1
9J1121674A	 <p>Air duct, right side</p>	1
9J1121673A	 <p>Air duct, left side</p>	1

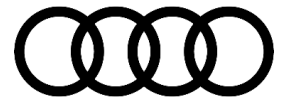

Technical Service Bulletin

Additional Information

The following Technical Service Bulletin may be necessary to complete this procedure:

- TSB 2073030, *19 Grinding or knocking noises from electric cooling fans when active*

All parts and service references provided in this TSB (**2073599**) are subject to change and/or removal.

©2024 Audi of America, Inc. All rights reserved. The information contained in this document is based on the latest information available at the time of printing and is subject to the copyright and other intellectual property rights of Audi of America, Inc., its affiliated companies, and its licensors. All rights are reserved to make changes at any time without notice. No part of this document may be reproduced, stored in a retrieval system, or transmitted in any form or by any means, electronic, mechanical, photocopying, recording, or otherwise, nor may these materials be modified or reposted to other sites without the prior expressed written permission of the publisher.