



STAR ONLINE PUBLICATION



Case Number: S2408000064

Release Date: June 2024

Symptom/Vehicle Issue: Blind Spot Warning Message Displayed on the Cluster

Customer Complaint/Technician Observation: The customer may complain of a cluster blind spot warning message. The technician may find one or more Diagnostic Trouble Codes (DTCs) below.

- C00C0-76 Front Radar Module “A” Wrong Mounting Position (Front left mid-range radar)**
- C00C2-76 Front Radar Module “C” Wrong Mounting Position (Front right mid-range radar)**
- C00C4-76 Rear Radar Module “A” Wrong Mounting Position (Rear left mid-range radar)**
- C00C5-76 Rear Radar Module “B” Wrong Mounting Position (Rear right mid-range radar)**

Discussion: The mid-range radars are self-calibrating. If the radar calibrates a large enough angle error, it will send a fault code to the Central ADAS Decision Module (CADM) (Via private CAN C bus). Then the CADM sends a fault code to the vehicle (See above listed fault codes) indicating the system is functioning properly with a need to inspect, **(Do not replace mid-range radar module for the above DTCs).**

The DTCs indicate that a radar mounting position is incorrect.

1. The radar may be improperly attached to its bracket (Figures 2 & 4).
2. The bracket may be damaged (Figures 3 & 4).
3. The front fascia (Figure 5) may be damaged (Front mid-range radars).
4. The valence (Figure 3) may be damaged (Rear mid-range radars).
5. The rear bumper (Figure 3) may be damaged.

NOTE: Physical inspection required, any damages may cause the radar mounting position to be incorrect. A damaged rear bumper may cause the mounting bracket, and valence, to be pulled out of position (Radar mounting position incorrect). These conditions will generate a wrong mounting position fault code.

This document does not authorize warranty repairs. This communication documents a record of past experiences. STAR Online does not provide any conclusions about what is wrong with the vehicle. Rather, it captures all previous cases known that appear to be similar or related to the vehicle symptom / condition. You are the expert, and you are responsible for deciding on the appropriate course of action.

Contact STAR Center, or your Technical Assistance Center Via TechConnect, eCONTACT or Service Library entry if no solution is found.



STAR ONLINE PUBLICATION



Re-attach the mid-range radar, and/or repair/replace any of the above listed components as needed. After fixing/replacing/reattaching, the vehicle must be driven on the road for about 15 minutes. The drive must have targets for the radar to see. This means, other vehicles driving on the road (Dynamic targets), and stationary targets (Parked cars, traffic signs, etc). Do not drive on empty roads with little or no targets, otherwise, the radar will not calibrate. Upon completion of the drive cycle, the active fault code will go stored (Cycle ignition to off, and then back to on, and check with Witech tool). If the fault code is still active, there were not enough targets for radar self-calibration, or the problem component(s) have not been fixed (Radar mounting position is incorrect).

NOTE: The Witech tool is not required for the drive cycle (The mid-range radar self-calibrates).

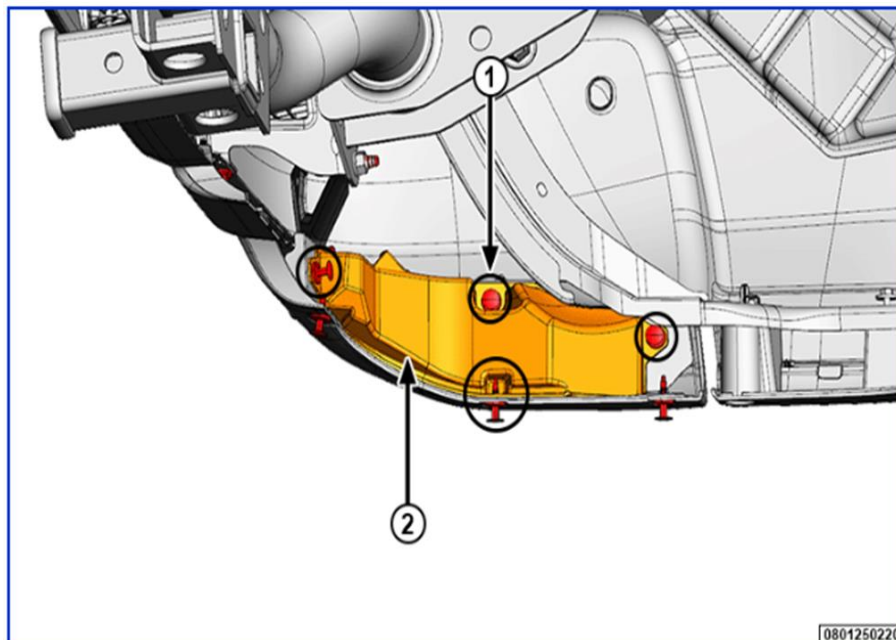

- 1 - Push Fasteners
- 2 - Closeout Panel

Fig 1

This document does not authorize warranty repairs. This communication documents a record of past experiences. STAR Online does not provide any conclusions about what is wrong with the vehicle. Rather, it captures all previous cases known that appear to be similar or related to the vehicle symptom / condition. You are the expert, and you are responsible for deciding on the appropriate course of action.

Contact STAR Center, or your Technical Assistance Center Via TechConnect, eCONTACT or Service Library entry if no solution is found.



STAR ONLINE PUBLICATION

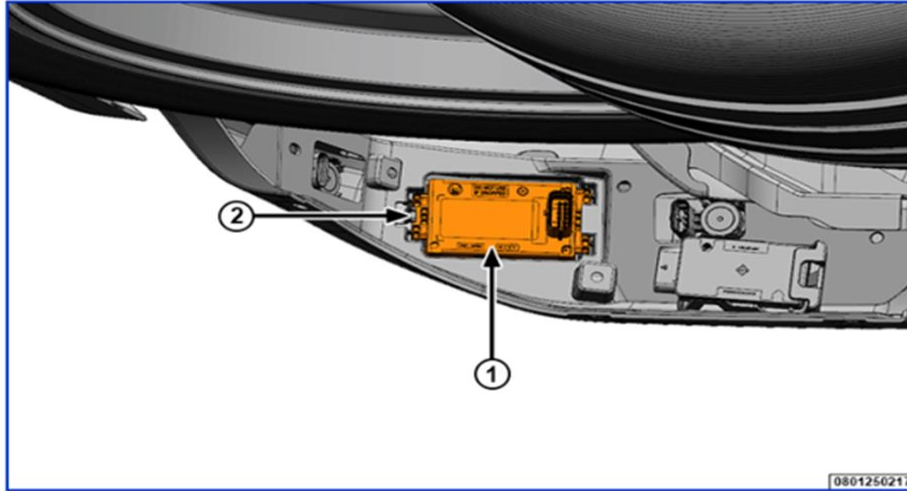

- 1 - Mid-Range Radar Rear
- 2 - Tab

Close out panel removed

Fig 2

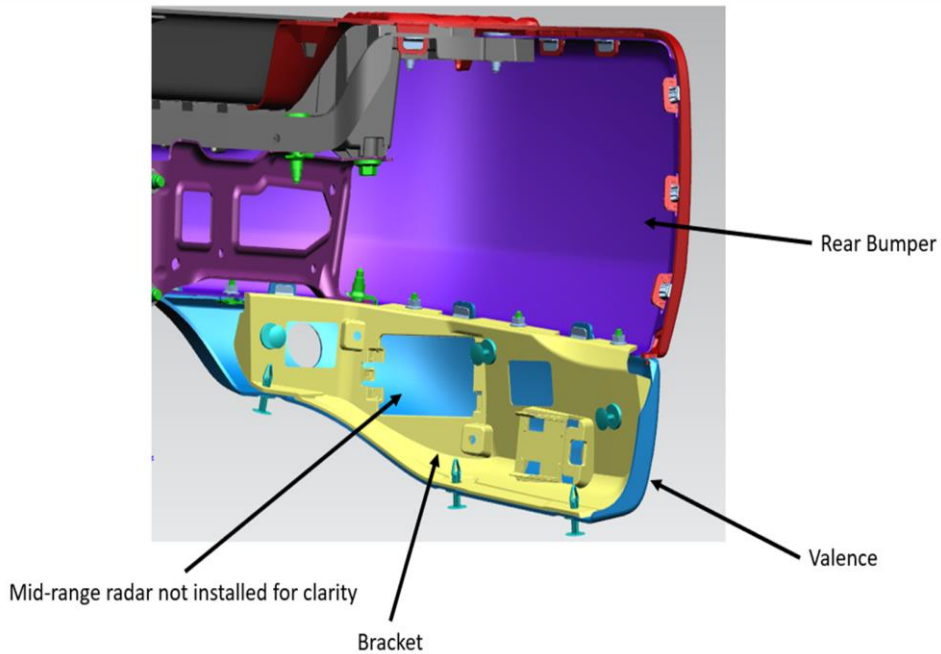

Fig 3

This document does not authorize warranty repairs. This communication documents a record of past experiences. STAR Online does not provide any conclusions about what is wrong with the vehicle. Rather, it captures all previous cases known that appear to be similar or related to the vehicle symptom / condition. You are the expert, and you are responsible for deciding on the appropriate course of action.

Contact STAR Center, or your Technical Assistance Center Via TechConnect, eCONTACT or Service Library entry if no solution is found.



STAR ONLINE PUBLICATION

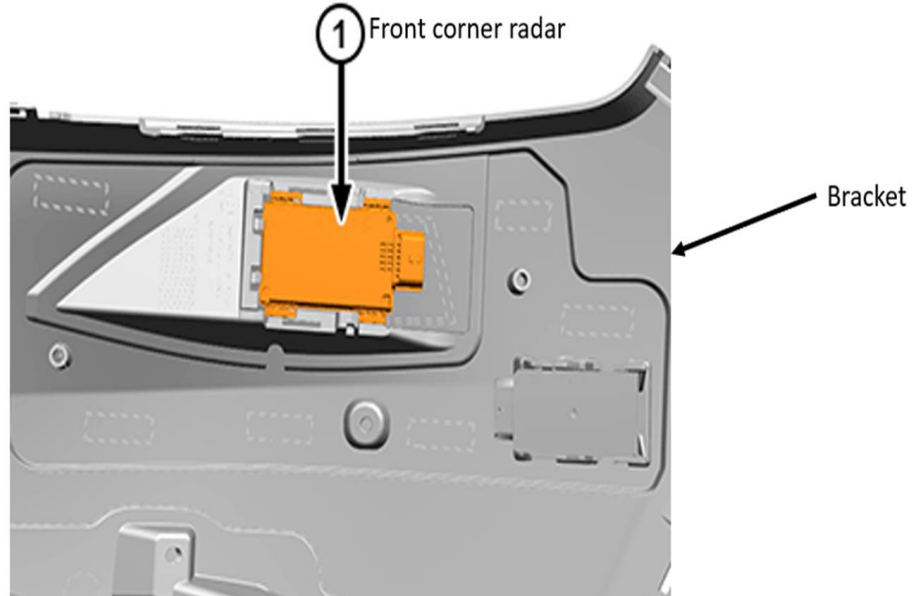

Fig 4

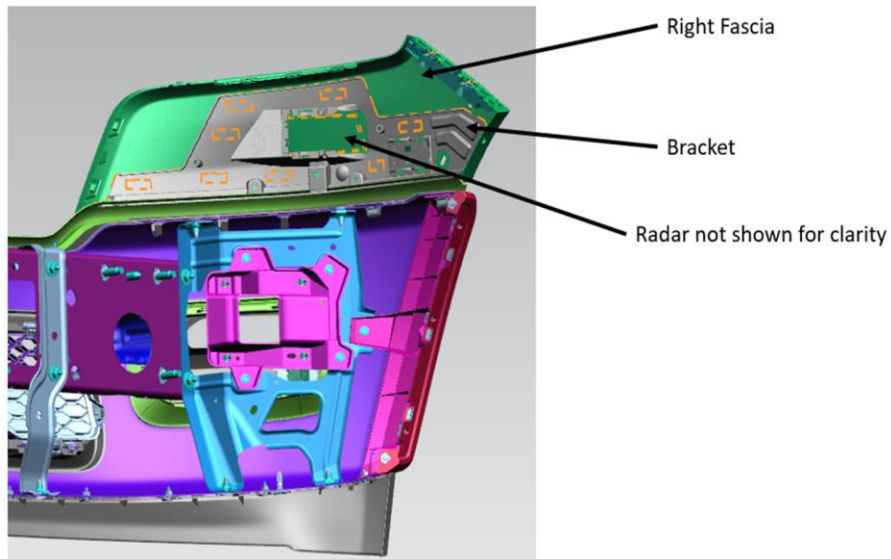

Fig 5

This document does not authorize warranty repairs. This communication documents a record of past experiences. STAR Online does not provide any conclusions about what is wrong with the vehicle. Rather, it captures all previous cases known that appear to be similar or related to the vehicle symptom / condition. You are the expert, and you are responsible for deciding on the appropriate course of action.

Contact STAR Center, or your Technical Assistance Center Via TechConnect, eCONTACT or Service Library entry if no solution is found.