

June 19, 2024

Version 5

Warranty Extension: 2016-2021 Civic A/C Compressor Shaft Seal Leak (1.5T, 2.0, 2.0T)

Supersedes 23-039, dated January 18, 2024, to revise the information.

AFFECTED VEHICLES

Year	Model	Trim	VIN Range
2016–2021	Civic	1.5T	Check the iN VIN status for eligibility
2016–2021	Civic	2.0	Check the iN VIN status for eligibility
2017–2021	Civic Type R	2.0T	Check the iN VIN status for eligibility

REVISION SUMMARY

REQUIRED MATERIALS removed a discontinued part number.

BACKGROUND

Due to a new North America regulation which introduces a new refrigerant and oil requirement, the compressor shaft seal may leak. American Honda is extending the warranty on the A/C compressor shaft seal from the original **3 years** to **10 years** from the original date of purchase, with no mileage limitation.

The new refrigerant and oil may cause swelling of the compressor shaft seal. The swelling may lead to abnormal wearing of the seal which may increase seal gaps around the compressor shaft allowing refrigerant to leak out.

This warranty extension will not apply to any vehicle that has ever been declared a total loss or sold for salvage by a financial institution or insurer, or has a branded or similar title under any state's law.

CUSTOMER NOTIFICATION

Owners of affected vehicles will be sent a notification of this campaign.

Do an iN VIN status inquiry to make sure the vehicle is shown as eligible.

CORRECTIVE ACTION

Do the inspection procedure and if directed, replace the compressor shaft seal.

CUSTOMER INFORMATION: The information in this bulletin is intended for use only by skilled technicians who have the proper tools, equipment, and training to correctly and safely maintain your vehicle. These procedures should not be attempted by "do-it-yourselfers," and you should not assume this bulletin applies to your vehicle, or that your vehicle has the condition described. To determine whether this information applies, contact an authorized Honda automobile dealer.

PARTS INFORMATION

Description	Part Number	Quantity
Seal Set Assembly Kit (Contains: Bolt, Washer Set, Pulley C-Ring, Felt Washer, Shaft Seal, C-Ring Seal, Suction Port Plug, Discharge Port Plug)	38918-64A-318	1
O-Ring (1/2")	80872-SN7-003	1
O-Ring (5/8")	80871-SN7-003	1

REQUIRED MATERIALS

Description	Part Number	Quantity
RB100EV Oil	38899-64A-A02	1

TOOLS INFORMATION

Part Name	Part Number	Quantity
A/C Compressor Seal Puller	07AAC-5AAA100	1
A/C Compressor Seal Guide	07AAG-5AAA101	1
A/C Compressor Seal Driver	07AAE-5AAA101	1
6CVC Seal Press (1.5L)	07AAD-5AAA101	1
6CVC Seal Press (2.0L)	07AAD-5BAA100	1

The above tools were auto-shipped to dealers in December 2022. For support or replacements, please contact Special Tools Hotline at (800) 346-6327. The original replacement kits have been discontinued.

WARRANTY CLAIM INFORMATION

Operation Number	Description	Flat Rate Time	Defect Code	Symptom Code	Template ID	Failed Part Number
6141D4	AC compressor seal replacement (includes inspection, evacuate and recharge)	2.1 hr	6A500	RE800	A23039A	38810-5BA-A03

VISUAL INSPECTION PROCEDURE

1. Remove the right-front tire.
2. Remove the engine undercover.

SCREWS (2)
9.3 N.m (6.9 lb-ft)
Remove.

CLIPS (19)
Remove.

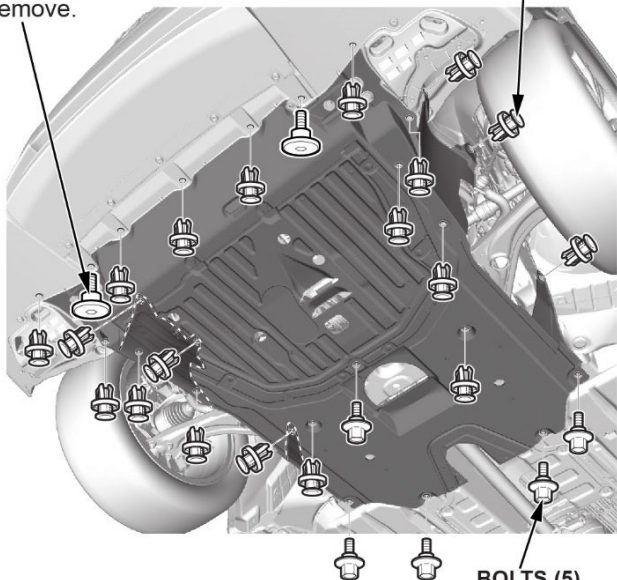

BOLTS (5)
9.3 N.m (6.9 lb-ft)
Remove.

3. Remove the drive belt.

NOTE: This is a hydraulic type auto-tensioner so turn the wrench slowly for at least **3 seconds**.

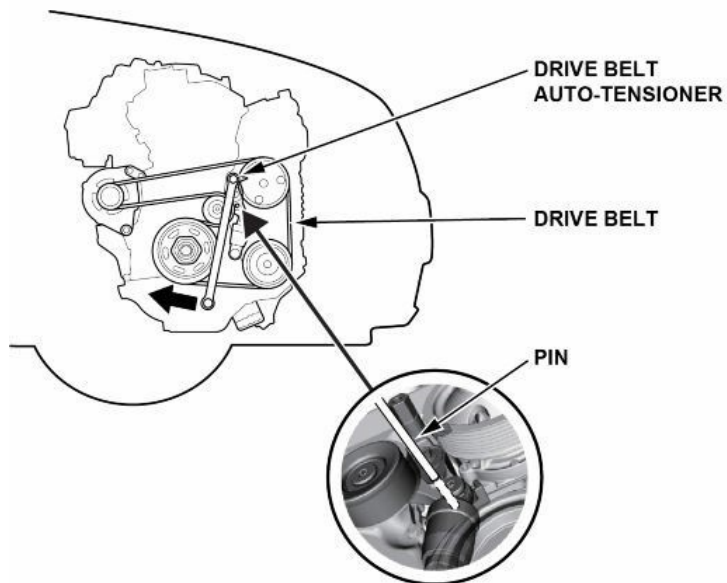

4. Inspect for oil on the armature plate surface of the compressor.

NOTE: If any oil is stuck to the armature plate surface of the compressor, then proceed to the repair procedure.

Inspect for oil.

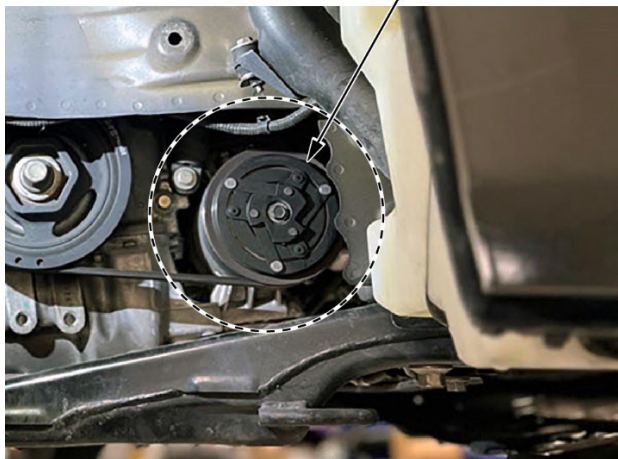

5. If no oil is noticed, leave the compressor on the vehicle. Remove the center hub bolt and armature plate from the compressor. Then, inspect both for oil.

NOTE:

- If oil is present on the armature plate, then proceed to the repair procedure.
- If no oil is present, then proceed to step 6.

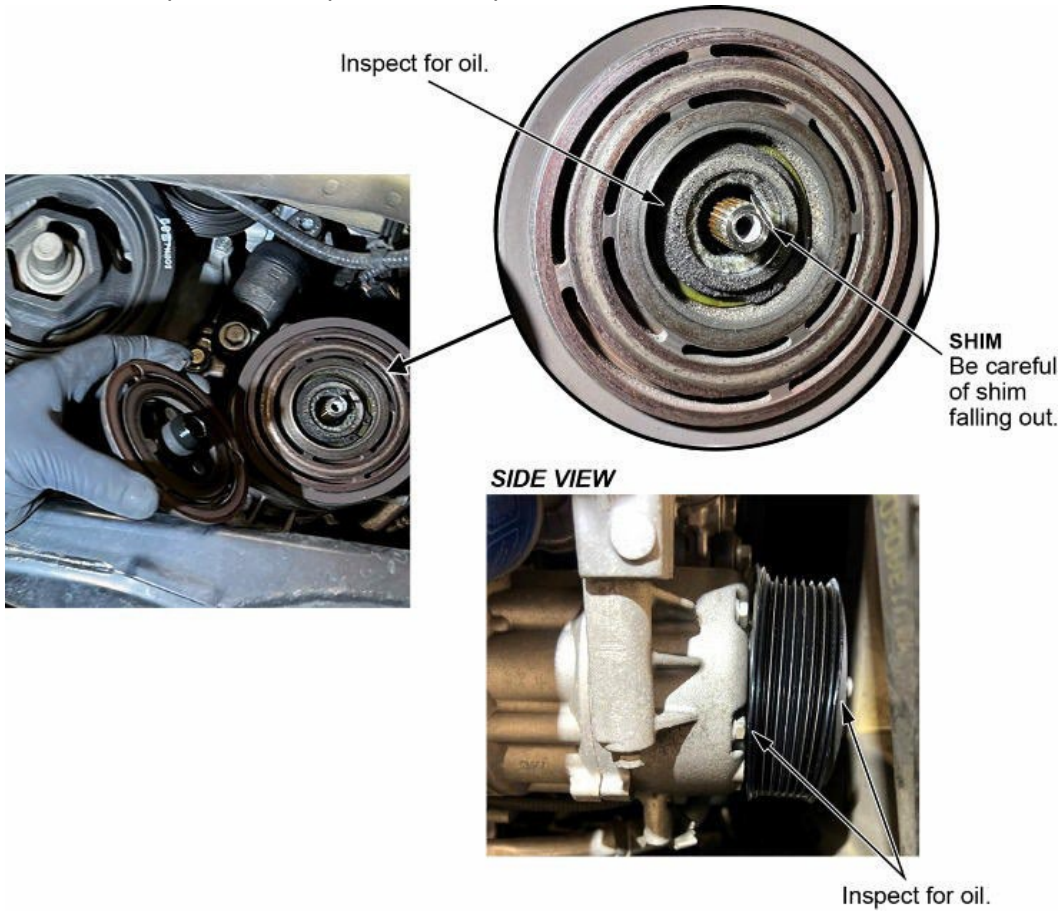

Examples of dry and oily armature assemblies.

Rotor	Hub	Rotor	Hub
Dry	Dry	Oily	Oily
			
			

6. Remove the felt washer from the compressor and gently place it on a clean sheet of copier paper.

NOTE: If oil transfers from the felt washer to the paper after **10 seconds**, proceed to the repair procedure. If not, proceed to step 7.

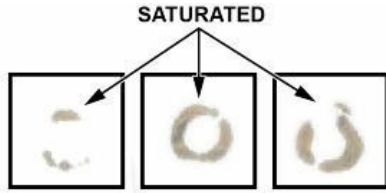

Observe for excess oil.

7. Using a calibrated leak detector, check for a leak.

NOTE:

- Use the leak detector for at least **five minutes** around the snout of the compressor.
- The longer an A/C compressor has not been ran, the better chance you will have at detecting a leak.
- A higher vehicle engine temperature produces more accurate results.
- If a leak is detected, proceed to the repair procedure.



SNOUT OF
COMPRESSOR

8. If no oil or leak is found, reassemble the hub/armature plate with the original bolt and torque to **(17 N·m or 13 lb-ft)**.

If this is a second time and no leak is found, reassemble the hub/armature plate with a new bolt and torque to **17 N.m (13 lb-ft)**.

NOTE:

- Verify that the armature plate and pulley rotate smoothly and independently.
- Measure the clearance between the pulley and armature plate all the way around. If clearance is not within specified limits, remove the armature plate and add/or remove shims as needed.
- Clearance: **0.30–0.60mm (0.012–0.024in)**
- Shims are available in three sizes: **0.3mm, 0.4mm, 0.5mm.**

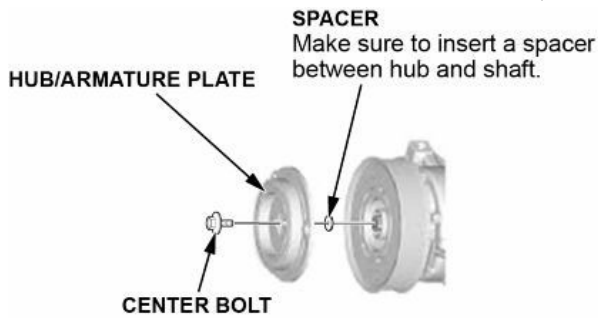

9. Reinstall the drive belt.

10. Run the vehicle for **ten minutes** and redo **step 7** again.

NOTE: If no leak or oil found after completing the second time, then continue with the normal oil leak check procedure of other A/C components.

REPAIR PROCEDURE

⚠ CAUTION

Chance for fluids to enter eyes and/or hands which can cause injury. Use safety glasses and rubber gloves.

Click here to view a video of the seal repair procedure:

▶ PLAY VIDEO

1. Connect an A/C recover/recycle/recharge machine to both the high-pressure service port and the low-pressure service port. Follow the equipment's manufacturer instructions.

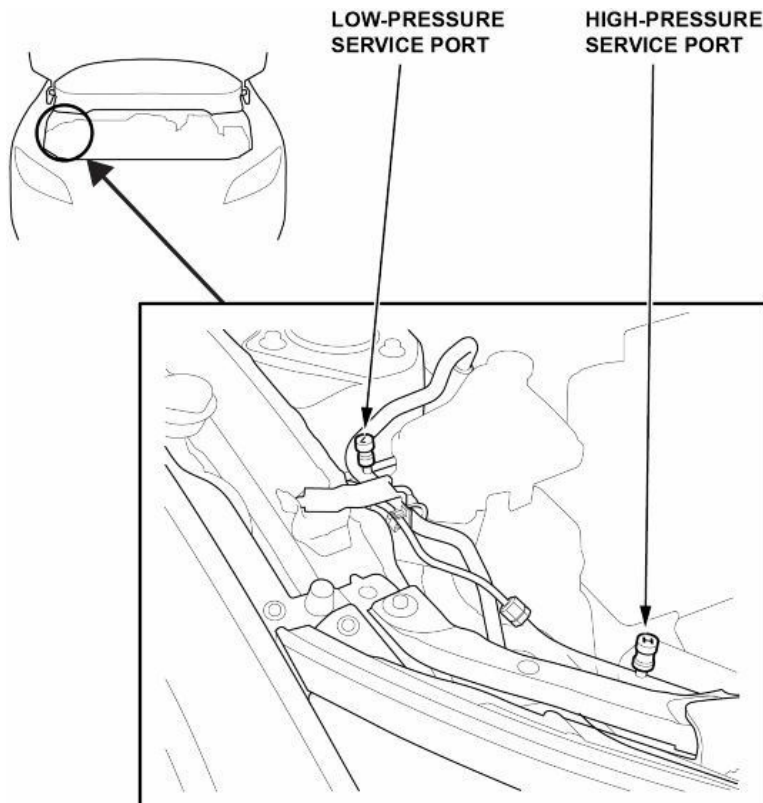

2. Recover the A/C refrigerant.

3. Disconnect the discharge and suction hoses.

NOTE:

- Use the port plugs in the seal assembly kit to immediately seal the ports after disconnection. This avoids moisture and dust contamination from entering the air conditioning compressor. Installing an A/C compressor into a contaminated system can result in premature A/C compressor failure.
- For the Type-R Models only: remove the charge air cooler inlet hose and A/C condenser fan shroud.

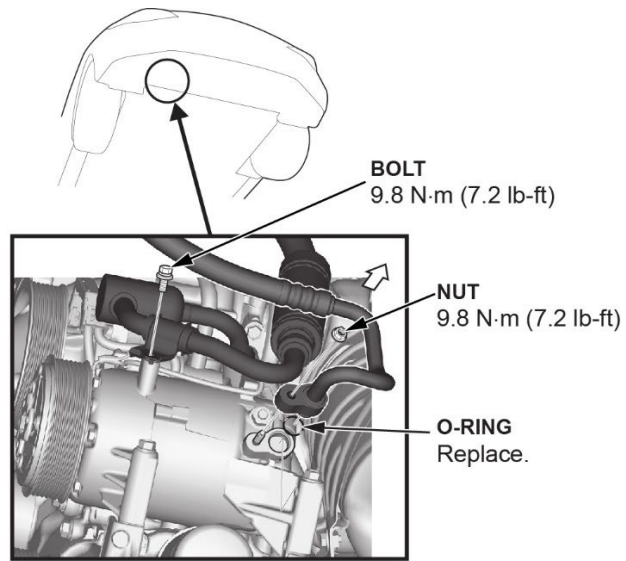
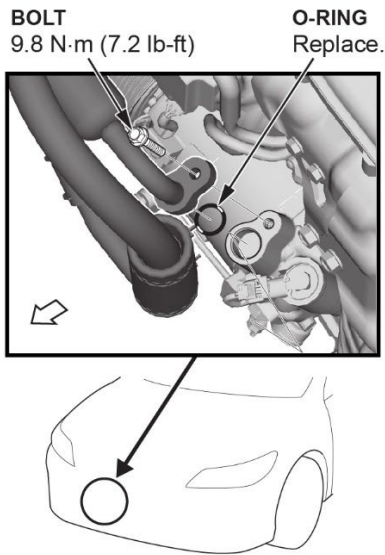

TYPE R

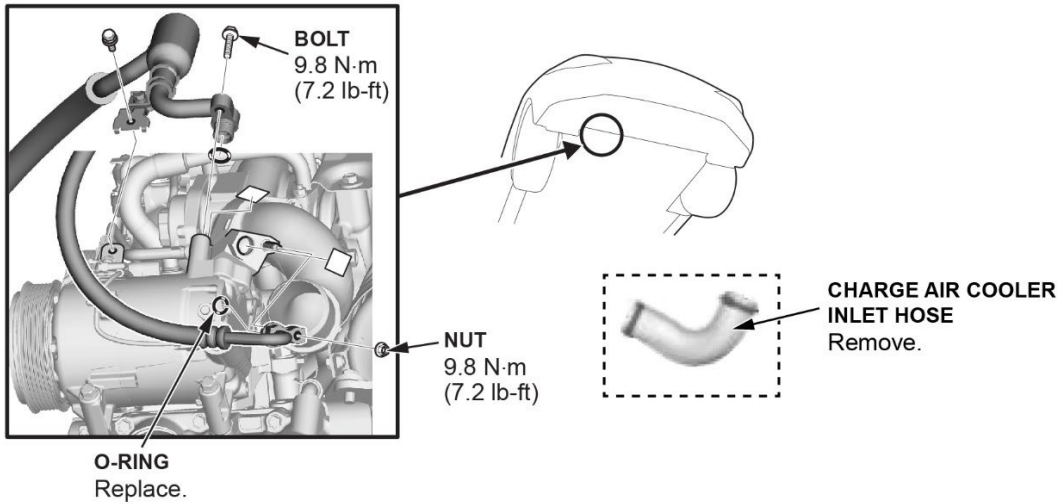

4. Remove the A/C compressor.

NOTE: Be careful not to damage the radiator fins while removing the A/C compressor.

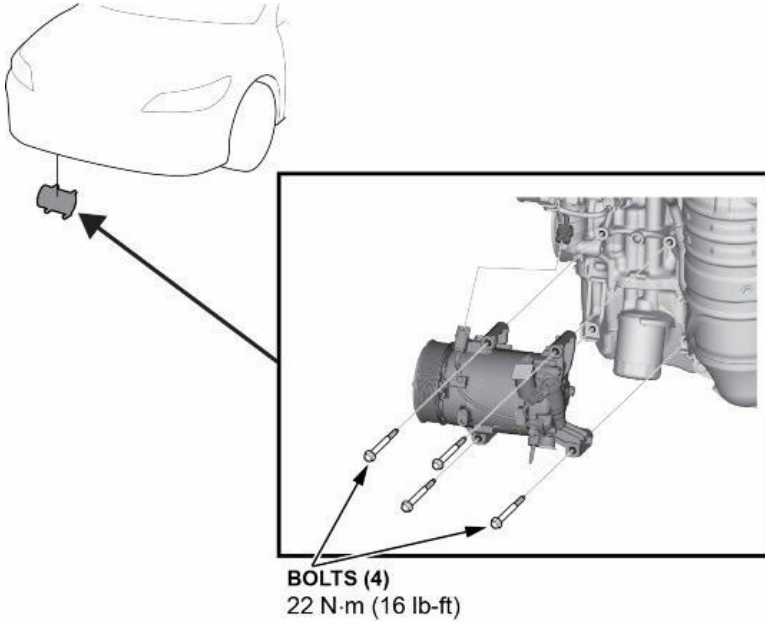

5. If not already removed, remove the center hub bolt (10 mm), tightened at 17 N·m (13 lb-ft).

NOTE: Make sure to wear proper PPE before continuing with the repair procedure.



6. If not already removed, remove the clutch, carefully, to not drop/lose any shims (usually 1–2 shims).

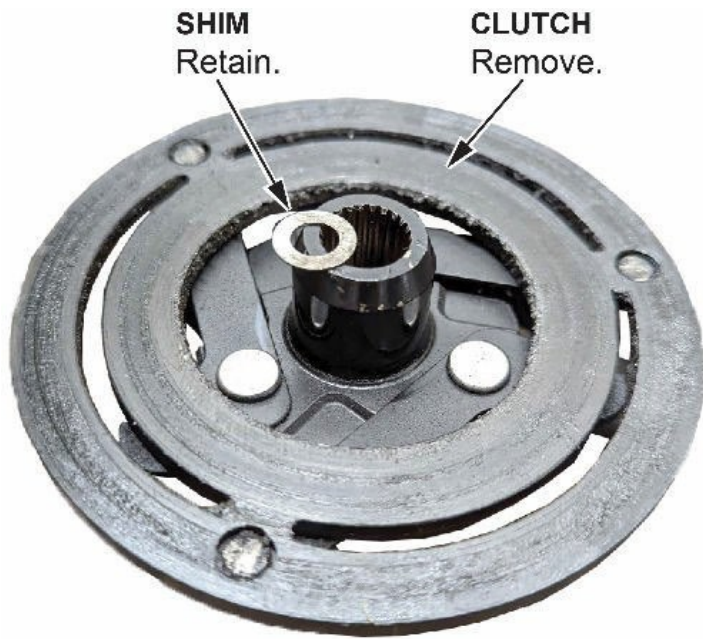

7. If not already removed, use a pick and remove the felt washer.

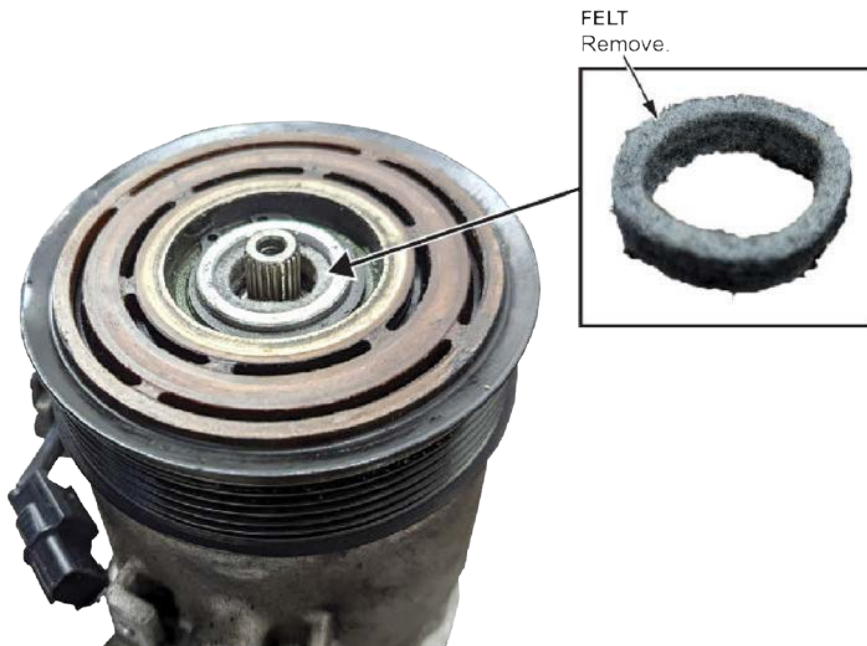

8. Remove the outer pulley C-ring.

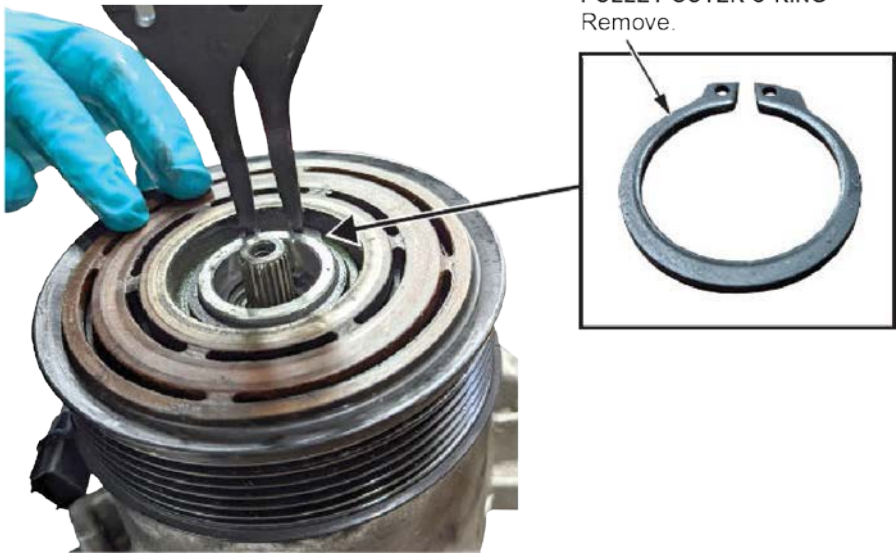

9. Remove the pulley.

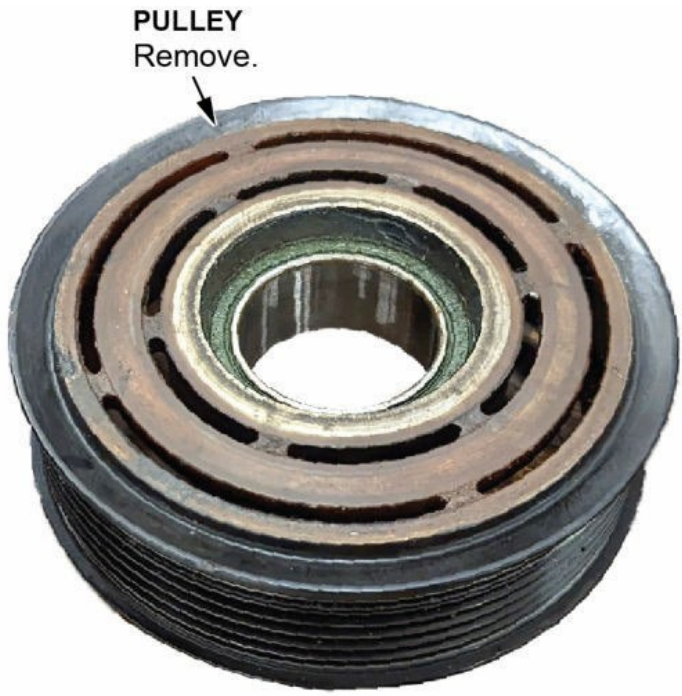

10. Remove the seal C-ring.

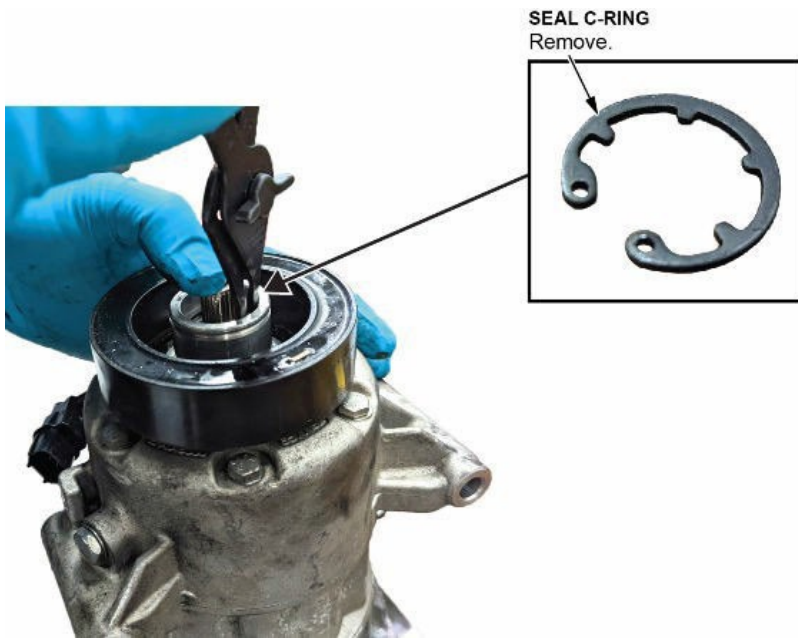

11. Thoroughly clean the bore and shaft with a lint free cloth.

NOTE: Do not use compressed air. The bore needs to be very clean as to prevent debris from entering the compressor once the seal is removed. Failure to remove all debris will result in a future failure.



12. Remove the side bracket.

1.5L ONLY



13. Place the press tool onto the A/C compressor and insert (2) holding pins. Make sure the press tool installs where the press shaft and compressor shaft align. The press tool will only align correctly in one orientation. The pins must be all the way through.

NOTE: The part numbers for the press tool are: 1.5T tool: 07AAD-5AAA101, 2.0 tool: 07AAD-5BAA100, and 2.0T tool: 07AAD-5BAA100.

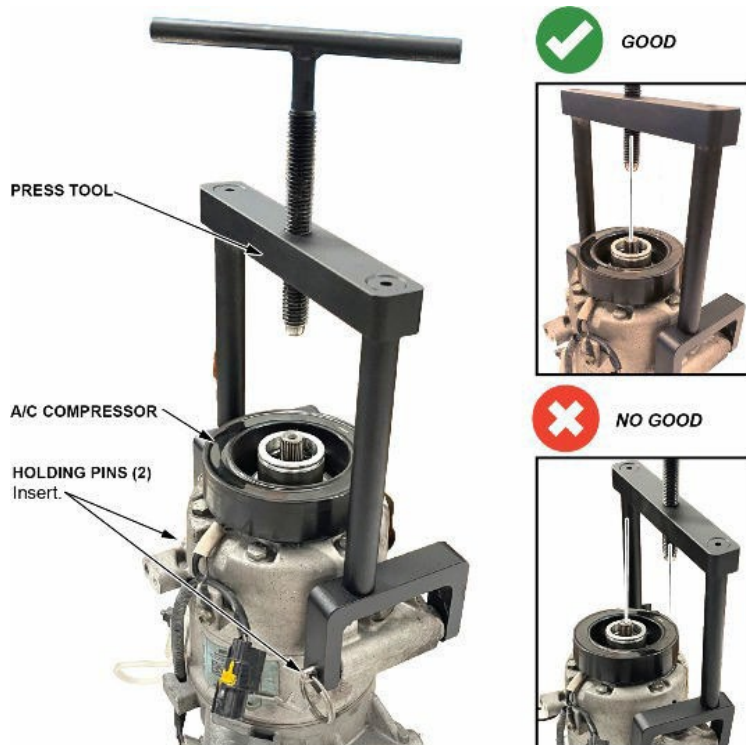

14. Add the press adapter tool.



15. Add grease to the press adapter button and press threads.

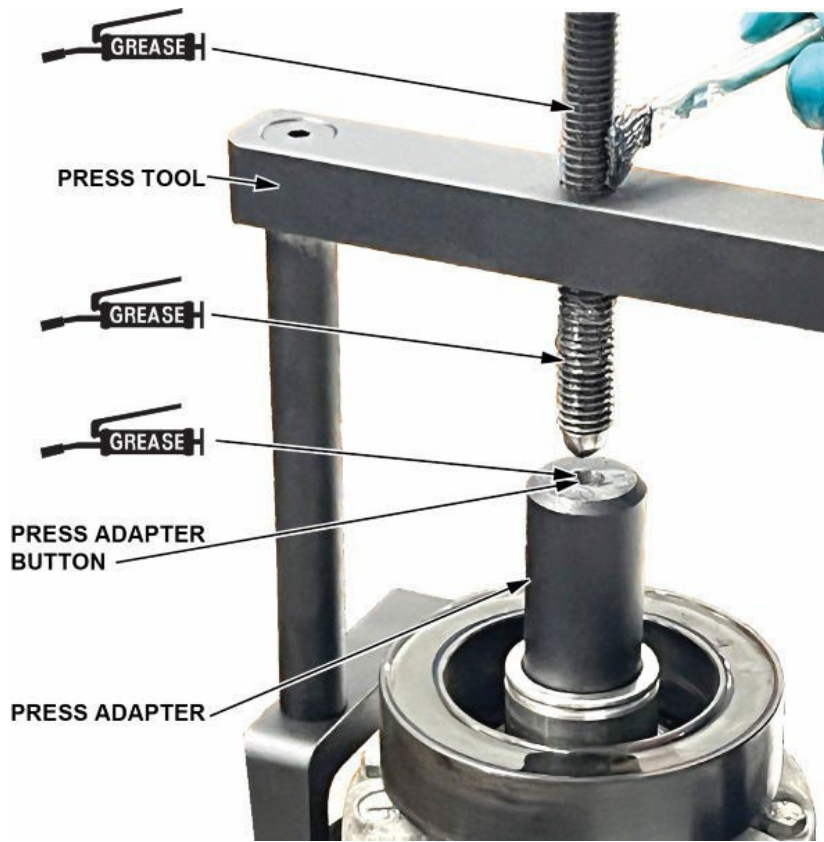

16. Tighten the press until there is no clearance, and then **3/4 turn (270°)**.

NOTE:

- The purpose of this step is to break the compressor shaft seal loose.
- Turning the handle more than **3/4 turn (270°)** can damage the tool and seal making it difficult to remove the compressor shaft seal.

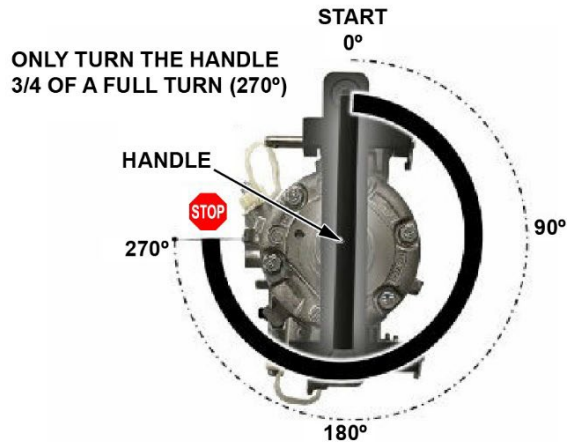

17. Remove the adapter and press tool.

18. Insert the cylinder tool onto the A/C compressor.

A/C COMPRESSOR



CYLINDER TOOL

CYLINDER TOOL



19. Insert the extractor tool, and make sure the **24 mm** nut is positioned towards the top. Look into the cylinder window to align the extractor tool onto the flange and press the handle fully down to grab the seal.

NOTE: The **24 mm** nut will use a **36 mm** wrench.

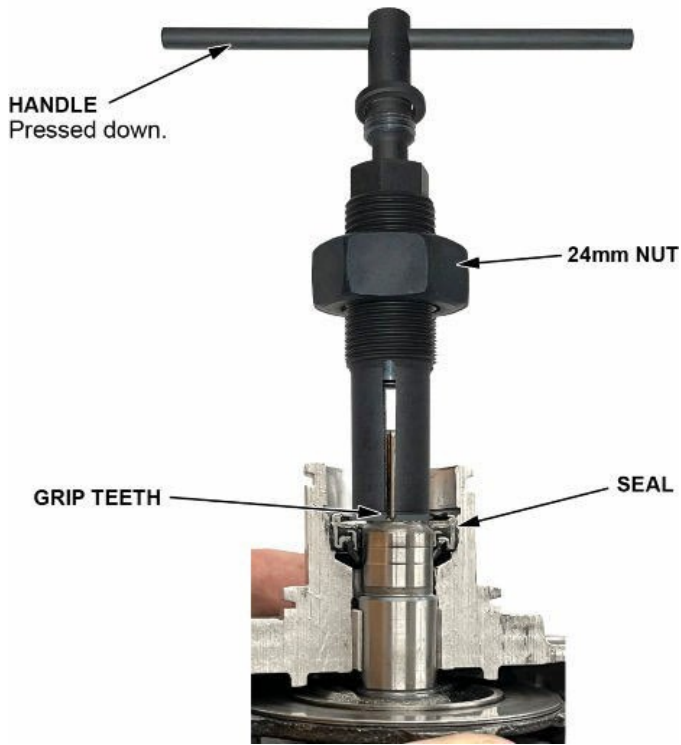

20. Stabilize the extractor tool using a **19 mm** wrench on the top. **Then**, turn the handle clockwise until resistance is felt. Make sure that the space between the **19 mm** wrench and the bottom portion of the extractor tool is minimal.

NOTE: To confirm the extractor is engaged, hold the extractor tool and lift the compressor up.

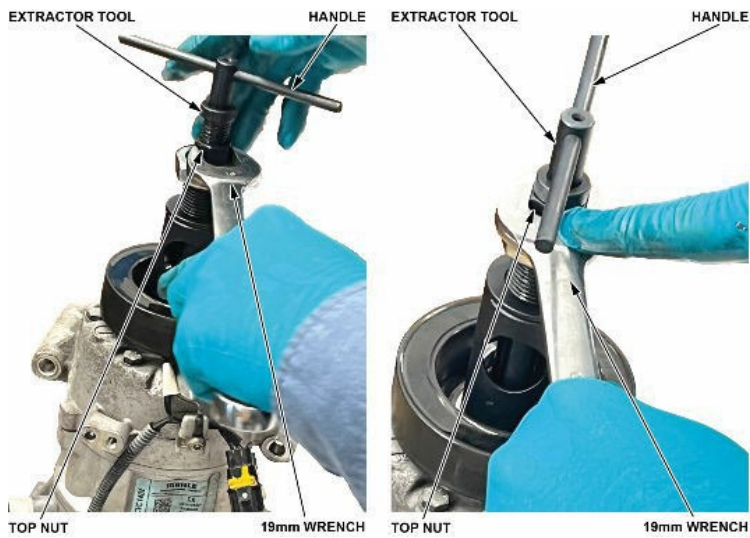

21. Apply grease between the **24 mm** nut and cylinder as well as cylinder top.

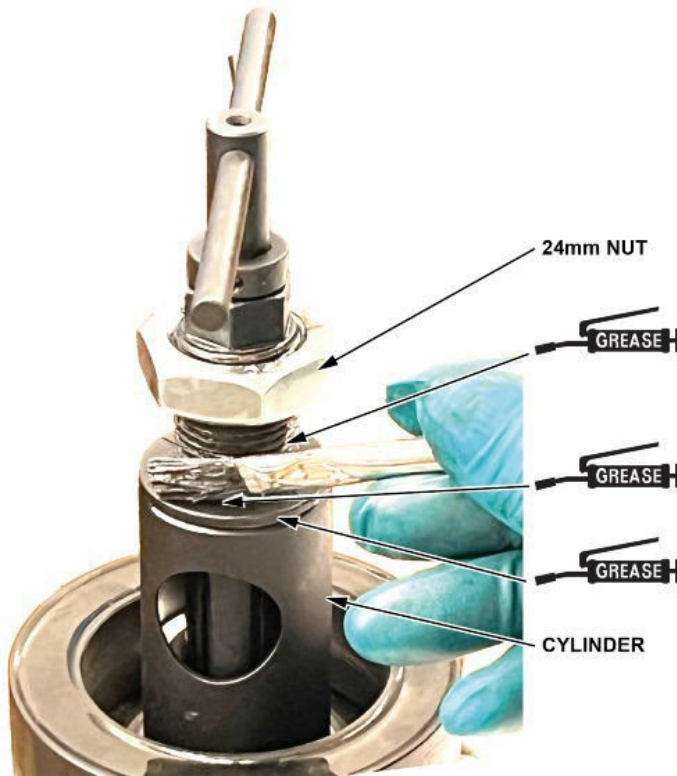

22. With the **19 mm** wrench in place, lower the **24 mm** nut down until it reaches the cylinder. Slowly and carefully adjust until the extractor tool comes out freely with the seal.

NOTE:

- Resistance will be felt while lowering **24 mm** nut and will cease once the seal is extracted.
- If the seal does not come out on the first step, repeat the process starting at step 13.

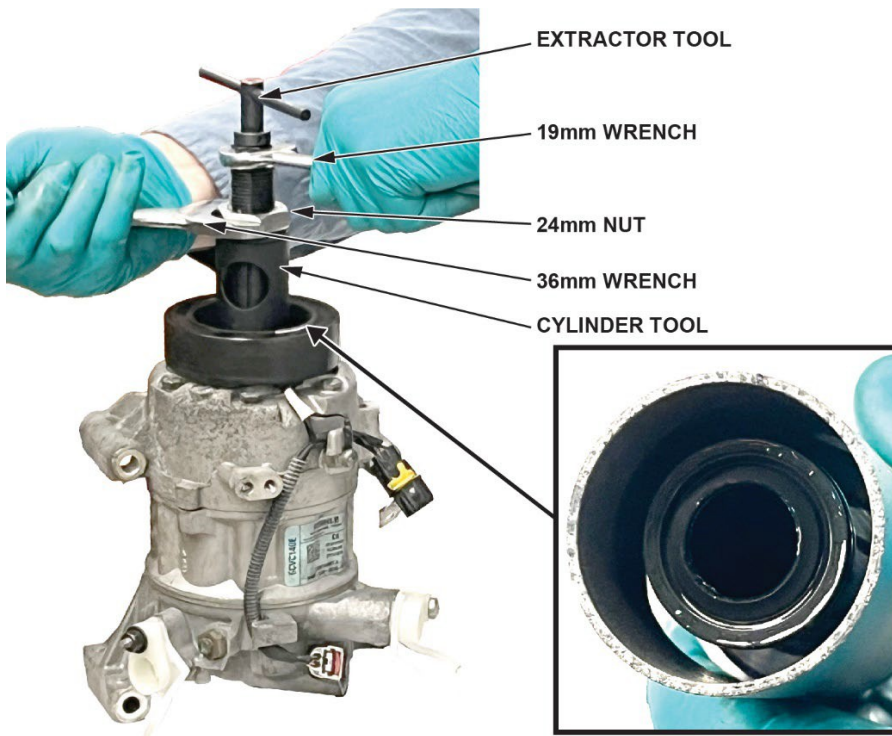

23. Thoroughly clean the bore and shaft with a lint free cloth.

NOTE: Do not use compressed air. The bore needs to be very clean as to prevent debris from entering the compressor once the seal is installed. Failure to remove all debris will result in future failure.

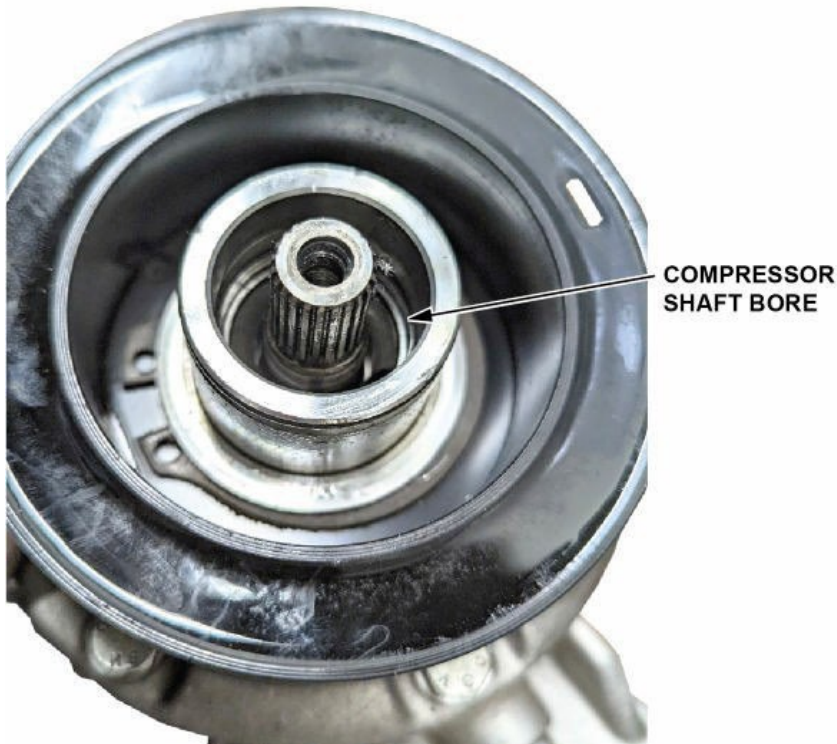

24. Inspect the compressor shaft bore for visible damage; Inspect the seal guide for contamination or damage.

25. Lubricate the new seal outer surface, seal guide, and bore with new POE compressor oil.

NOTE:

- Avoid touching the center of the seal to prevent cross-contamination of the A/C refrigerant system.
- Make sure to clean the surface using clean gloves and with a lint free cloth before lubrication.

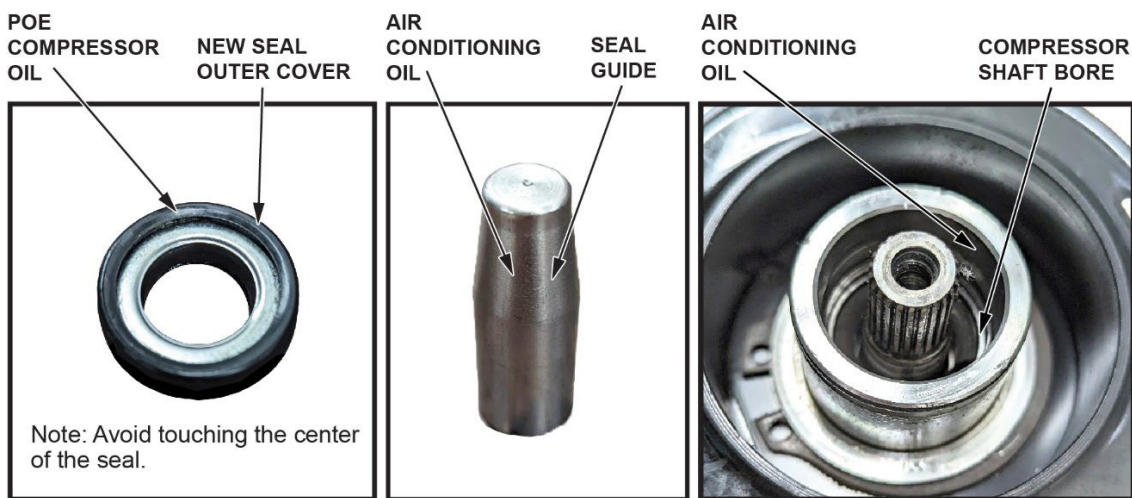

26. Insert the seal guide tool onto A/C compressor shaft.

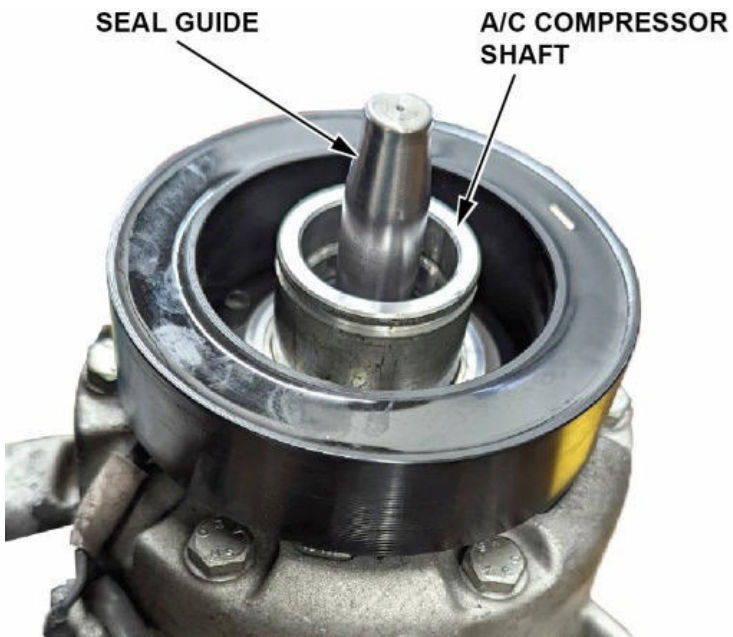

27. Insert the new seal onto the seal guide tool.

NOTE: The seal is directional and must be placed with the metal side upwards as shown below.



28. Insert the press adapter tool over the seal guide. By hand, press down just enough to seat and install the new seal.
 NOTE: Seat the seal about 5 mm below the top edge of the bore.



29. Insert the new seal C-ring with the teeth's rounded side pointing down into the bore.

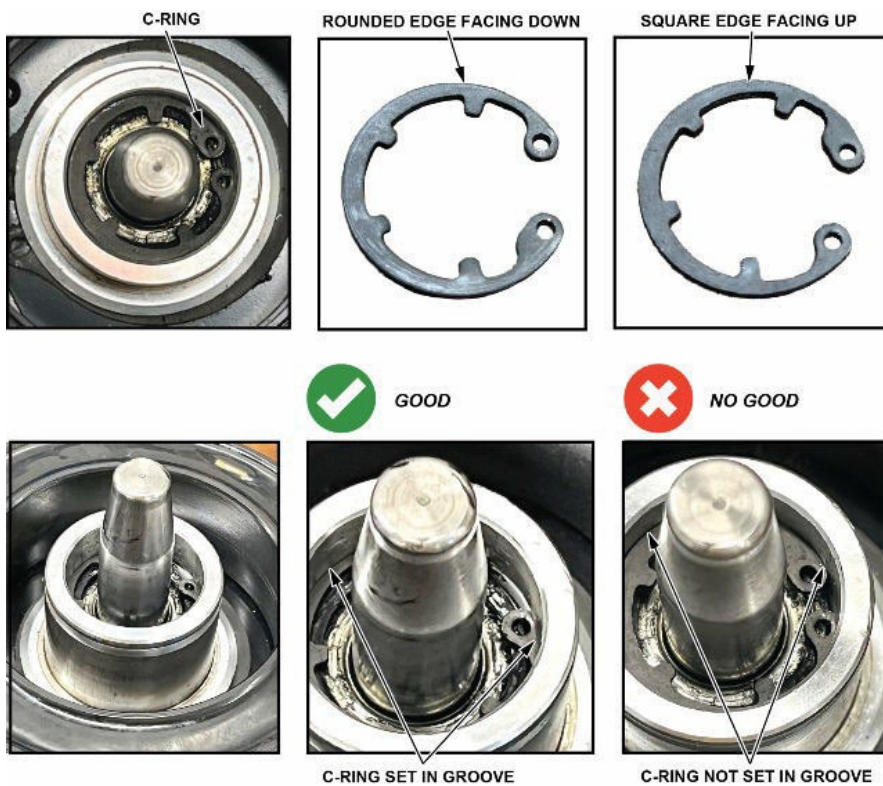

30. Add the press tool.

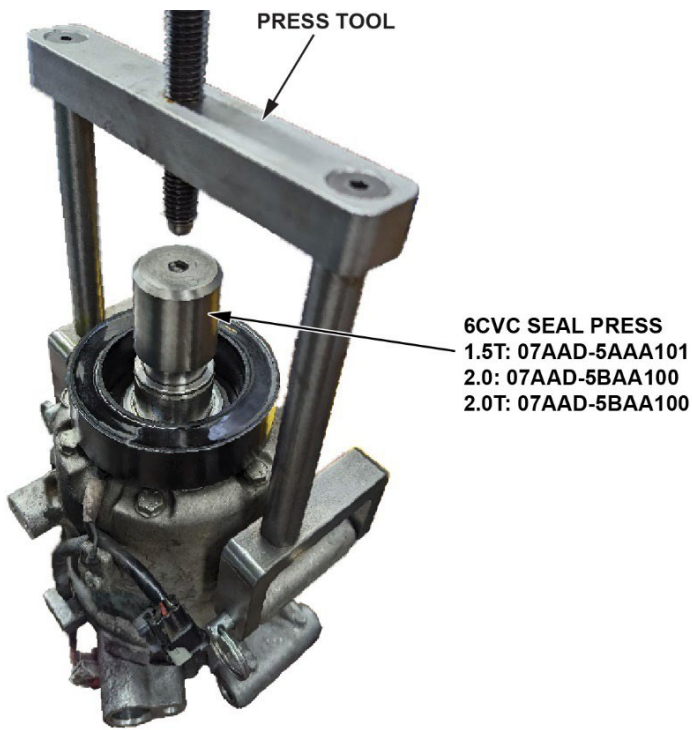

31. Tighten the press by rotating the handle clockwise until it reaches the adapter tool. Slowly and carefully continue to rotate the handle clockwise until the seal is pressed down roughly **10 mm** below the top edge of the bore.

NOTE: Tighten the press until the C-clip is installed into the clip groove. There will be a sound or vibration felt when the C-clip is fully set.

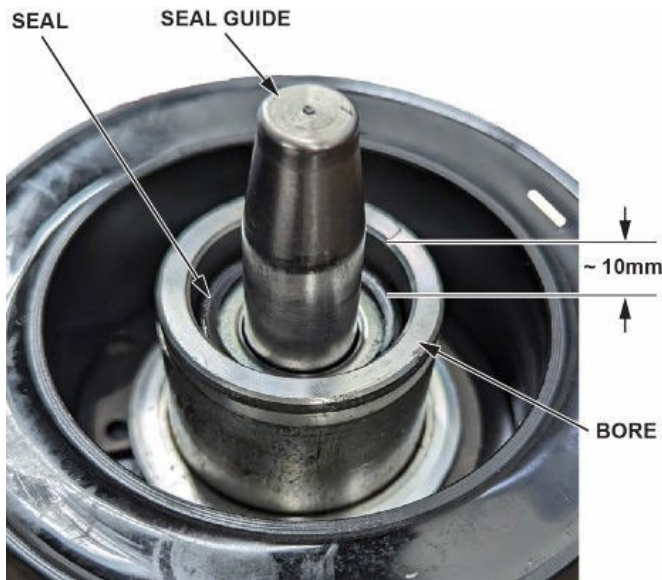

32. Remove the press and the adapter tool when successfully completed.

33. Clean the pulley and A/C compressor friction surfaces with Honda Brake Cleaner or equivalent.

34. Install the pulley.
35. Install the new pulley outer C-ring.
NOTE: C-ring for pulley and felt seal must be replaced.
36. Install the new felt washer.
37. Measure existing shims with caliper and make sure the thickness is the same.
38. Install the clutch plate and shims.
39. Add the new clutch center flange bolt and tighten to **17 N·m (13 lb-ft)**.
40. Fill compressor with one complete can of POE compressor oil.
41. Mount the side bracket.
42. Install the compressor.
43. Connect the suction and discharge hose.
NOTE: Make sure to replace O-rings as needed.
44. Install the drive belt.
45. Install the remaining parts.
46. If the system is OK, recharge A/C system. Fill the A/C system with the correct amount of A/C Refrigerant.
47. Set the A/C system to **MAX COOL**, and run the vehicle for **ten minutes** with between **1,500-2,000 RPM**.
48. Turn to the off mode. Use the calibrated leak detector to check around the shaft seal area, clutch area, and the O-ring area, without the engine running.
49. Install the undercover assembly and tire if no leak is detected.