

June 19, 2024

Version 8

A/C Does Not Blow Cold Air and Condenser Leaks at Receiver Dryer Cap

Supersedes 18-080, dated July 16, 2019, to revise the information highlighted in **yellow**

AFFECTED VEHICLES

Year	Model	Trim	VIN Range
2016-18	Pilot	ALL	ALL
2019	Pilot	2WD	5FNYF5...KB000001 thru 5FNYF5...KB042834
2019	Pilot	AWD	5FNYF6...KB000001 thru 5FNYF6...KB090910
2017-18	Ridgeline	ALL	ALL
2019	Ridgeline	2WD	5FPYK2...KB000001 thru 5FPYK2...KB007659
2019	Ridgeline	AWD	5FPYK3...KB000001 thru 5FPYK3...KB039623
2019	Passport	2WD	5FNYF7...KB000001 thru 5FNYF7...KB007708
2019	Passport	AWD	5FNYF8...KB000001 thru 5FNYF8...KB019991

REVISION SUMMARY

REQUIRED MATERIALS part number changes.

SYMPTOM

The A/C does not blow cold air, and the lower corner of the condenser around the receiver/dryer cap is stained.

POSSIBLE CAUSES

There is poor O-ring compression against the receiver/dryer barrel wall.

CORRECTIVE ACTION

Remove the A/C condenser, and replace the filter sub-assembly. Then, recharge the A/C system.

CUSTOMER INFORMATION:The information in this bulletin is intended for use only by skilled technicians who have the proper tools, equipment, and training to correctly and safely maintain your vehicle. These procedures should not be attempted by "do-it-yourselfers," and you should not assume this bulletin applies to your vehicle, or that your vehicle has the condition described. To determine whether this information applies, contact an authorized Honda automobile dealer.

PARTS INFORMATION

Part Name	Part Number	Quantity
Filter Sub-Assembly	80101-TG7-A02	1

REQUIRED MATERIALS

Part Name	Part Number	Quantity
2019 Pilot 2WD & AWD (9AT) RB100EV	38899-64A-A02	1
2019 Passport RB100EV	38899-64A-A02	1
All other Models ND-Oil 14	38899-50Z-G04	1

WARRANTY CLAIM INFORMATION

The normal warranty applies.

Pilot, Passport, and Ridgeline without Honda Sensing

Operation Number	Description	Flat Rate Time	Defect Code	Symptom Code	Template ID	Failed Part Number
6161G3	Remove the A/C condenser, and replace the filter sub-assembly.	2.2 hrs	07406	03220	A18080A	80100-TG7-A01
620025	Evacuate and recharge the A/C system.	0.7 hr.				

Pilot and Passport with Honda Sensing

Operation Number	Description	Flat Rate Time	Defect Code	Symptom Code	Template ID	Failed Part Number
6161G3	Remove the A/C condenser, and replace the filter sub-assembly.	2.2 hrs	07406	03220	A18080B	80100-TG7-A01
M	Radar aiming- add	1.4 hrs				
620025	Evacuate and recharge the A/C system.	0.7 hr.				

Ridgeline with Honda Sensing

Operation Number	Description	Flat Rate Time	Defect Code	Symptom Code	Template ID	Failed Part Number
6161G3	Remove the A/C condenser, and replace the filter sub-assembly.	2.2 hrs	07406	03220	A18080C	80100-TG7-A01
M	Radar aiming- add	0.9 hr				
620025	Evacuate and recharge the A/C system.	0.7 hr				

Skill Level: Repair Technician

INSPECTION PROCEDURE

Check if the A/C is blowing cold air and there is staining around the receiver dryer cap on the condenser.

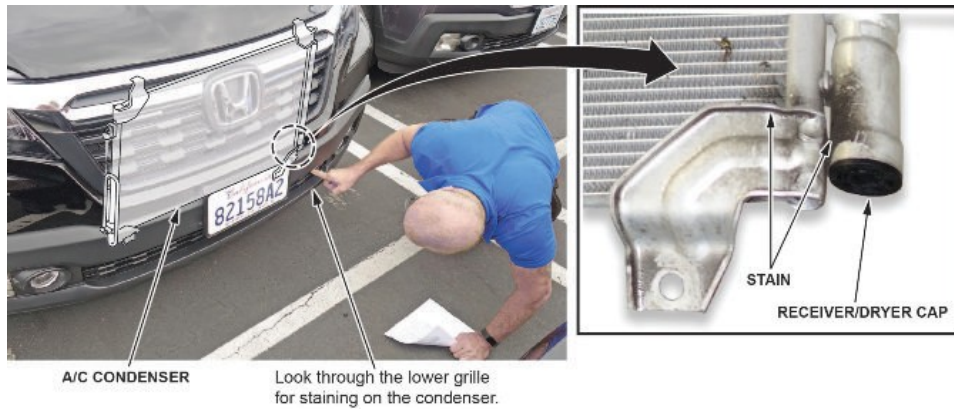

- If the A/C is not blowing cold air and there is staining around the receiver dryer cap on the condenser, go to REPAIR PROCEDURE.
- If the A/C is not blowing cold air and there is no staining around the receiver dryer cap, continue with normal system troubleshooting.

REPAIR PROCEDURE

1. Recover the A/C refrigerant from the system. Refer to the service information.
2. Remove the A/C condenser from the vehicle. Refer to the service information.
3. Thoroughly clean the stain from the affected area on the condenser.

- Remove the sub-assembly (cap, filter, and desiccant bag) from the condenser.

NOTES

- Install the new desiccant bag as quickly as possible to prevent the system from absorbing moisture from the air.
- You will need to add **10 ml** of refrigerant oil (P/N 38899-RLV-A01) with the replacement of the desiccant bag.
- Do not over tighten the plastic receiver/dryer cap; it could get stripped.

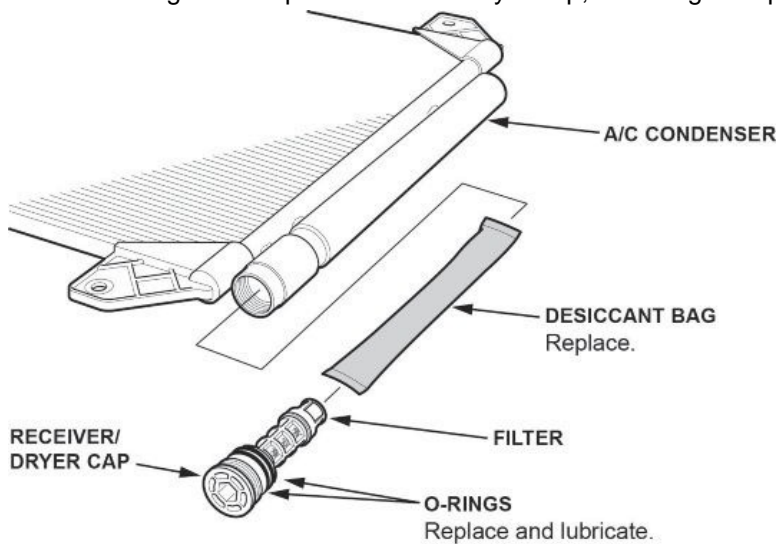

- Wipe the interior threads and sealing area of the receiver/dryer barrel with a lint-free cloth to remove all debris.
- Apply a thin layer of refrigerant oil to the O-rings. Then install the new filter sub-assembly, and torque the cap to **12 N·m (9 lb-ft)**.
- Install the A/C condenser. Refer to the service information.
- Evacuate and recharge the A/C system. Refer to the service information.
- Make sure the A/C system is operating properly.
- With Honda Sensing:* Do the millimeter wave radar aiming procedure. Refer to service information.

NOTE

The millimeter wave radar aiming procedure must be done whenever the millimeter wave radar is removed or replaced.

END