



TECHNICAL SERVICE BULLETIN

Classification: FA24-001	Reference: NTB24-023	Date: April 23, 2024
-----------------------------	-------------------------	-------------------------

POPPING NOISE FROM FRONT SUSPENSION WHEN TURNING

APPLIED VEHICLES: 2022-2024 Pathfinder (R53)

APPLIED DATES: Built on or before September 27, 2023

SERVICE INFORMATION

Individual strut components are available to service specific issues that have been diagnosed in a strut assembly.

If a strut has been confirmed as having a popping noise while turning, refer to the **Repair Overview** flow chart on page 2 to confirm that the **SERVICE PROCEDURE** on page 3 applies.

HINT: The **SERVICE PROCEDURE** in this bulletin is only meant to supplement the information found in the Electronic Service Manual (ESM). Refer to the ESM for information to remove and service the vehicle's struts.

Bulletins are intended for use by qualified technicians, not 'do-it-yourselfers'. Qualified technicians are properly trained individuals who have the equipment, tools, safety instruction, and know-how to do a job properly and safely. **NOTE:** If you believe that a described condition may apply to a particular vehicle, DO NOT assume that it does. See your Nissan dealer to determine if this applies to your vehicle.

Repair Overview

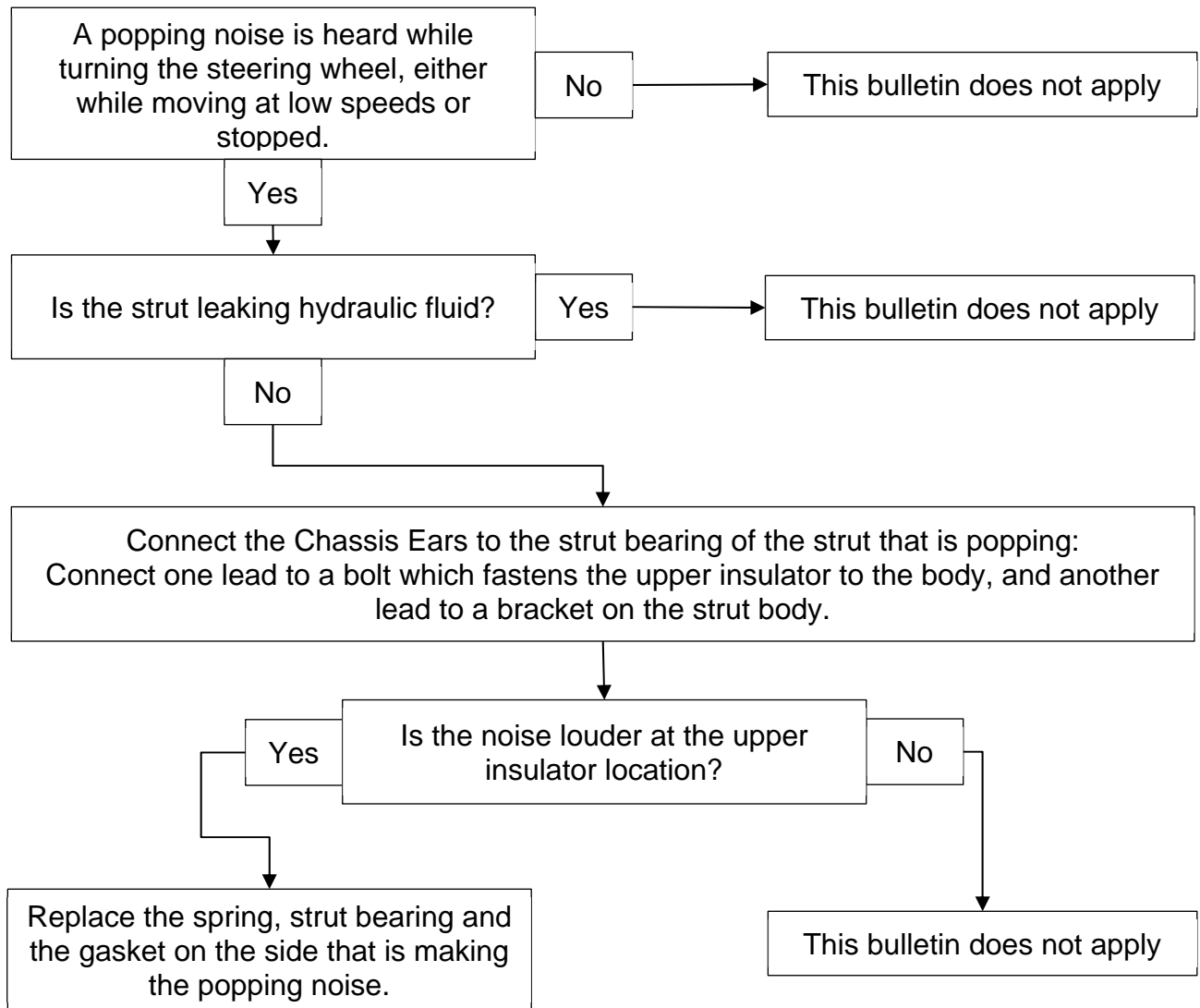

SERVICE PROCEDURE

If this bulletin applies, replace the front coil spring, strut mount bearing, and all other associated parts for the side(s) that is popping, with those listed under **PARTS INFORMATION** on page 7.

- Refer to the Electronic Service Manual (ESM): **SUSPENSION > FRONT SUSPENSION > UNIT DISASSEMBLY AND ASSEMBLY > FRONT COIL SPRING AND STRUT > Disassembly and Assembly**
- Position the coil springs as shown on pages 3-6.
- Check the front end alignment, and adjust to factory specifications as needed.

IMPORTANT:

- For an effective repair, all parts called out in Figure 1 must be replaced. These parts are also listed in the **PARTS INFORMATION** on page 7.

HINT: The Stabilizer Connecting Rod Nut, not shown in Figure 1, will also need to be replaced.

- The incident noise may return if all listed parts are not replaced.
- The **Coil Spring Installation Guidelines** section in this bulletin **MUST** be followed in order for a correct repair to be performed.

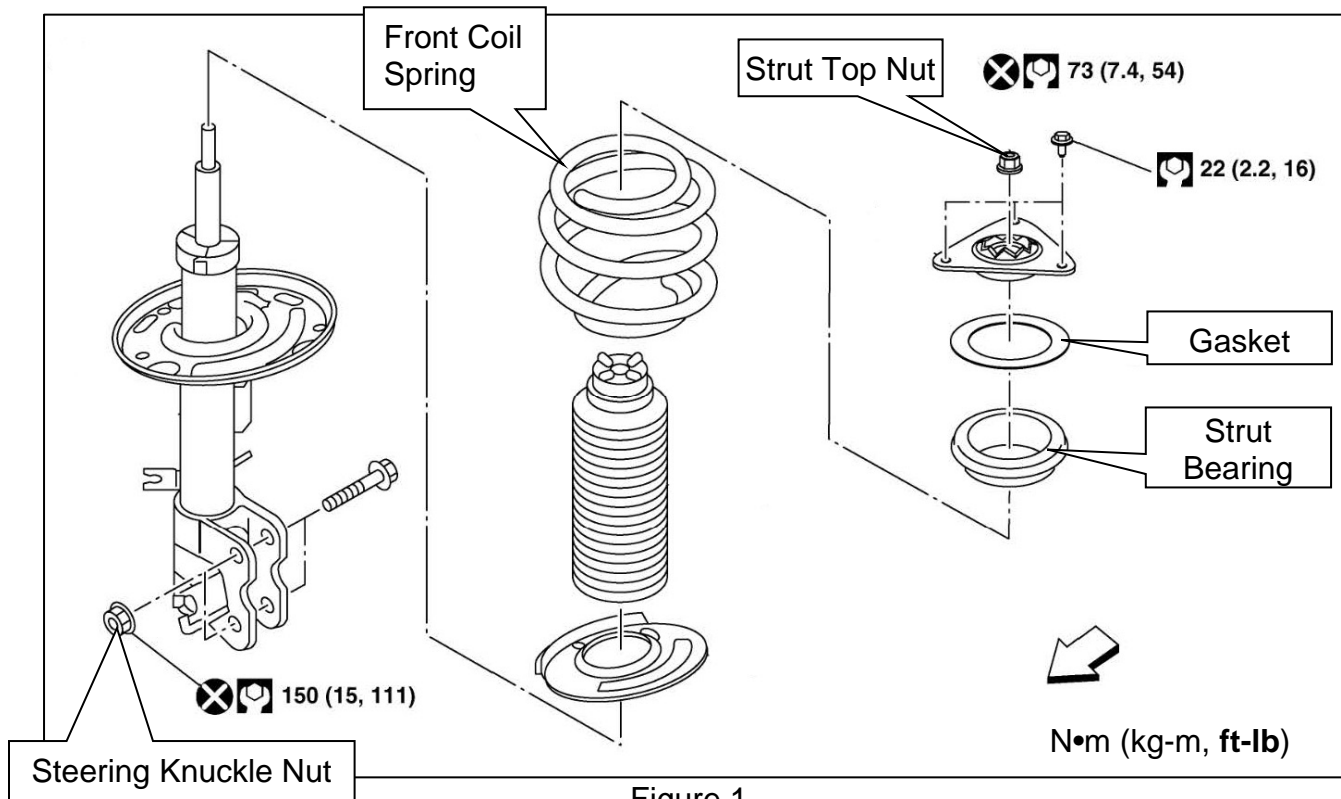

Coil Spring Installation Guidelines

Review the part number tag and confirm the part number is **54010-6SA0B**.

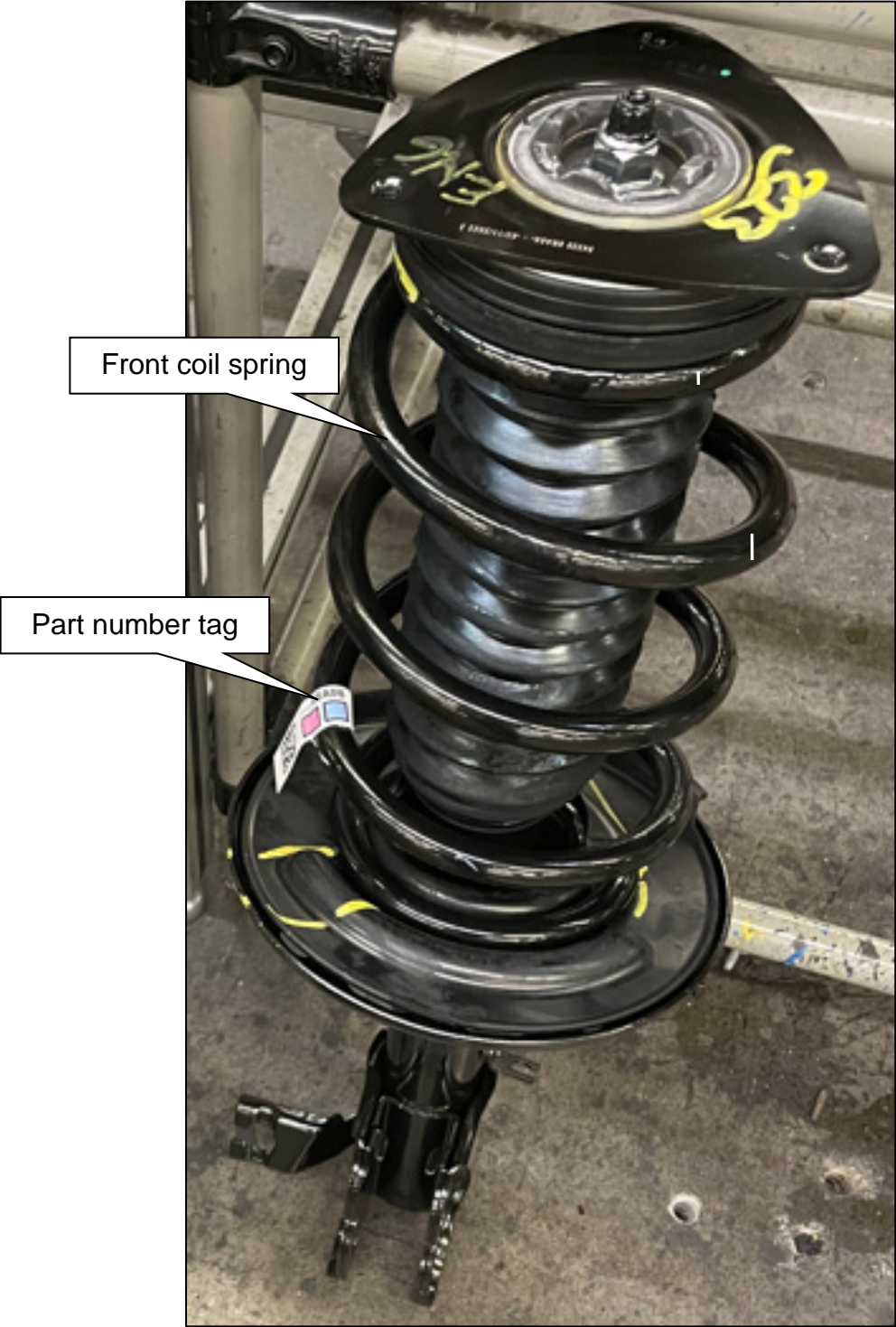

Figure 2

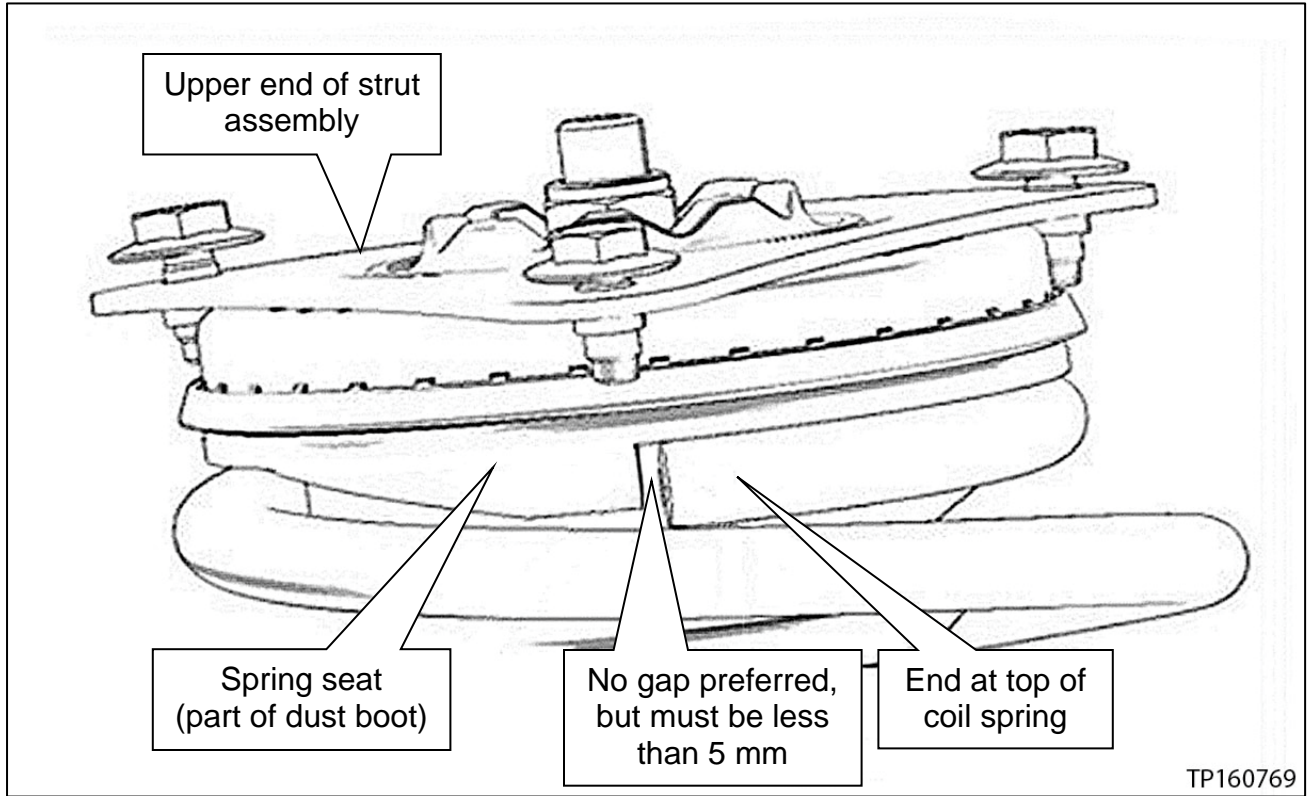

Figure 3

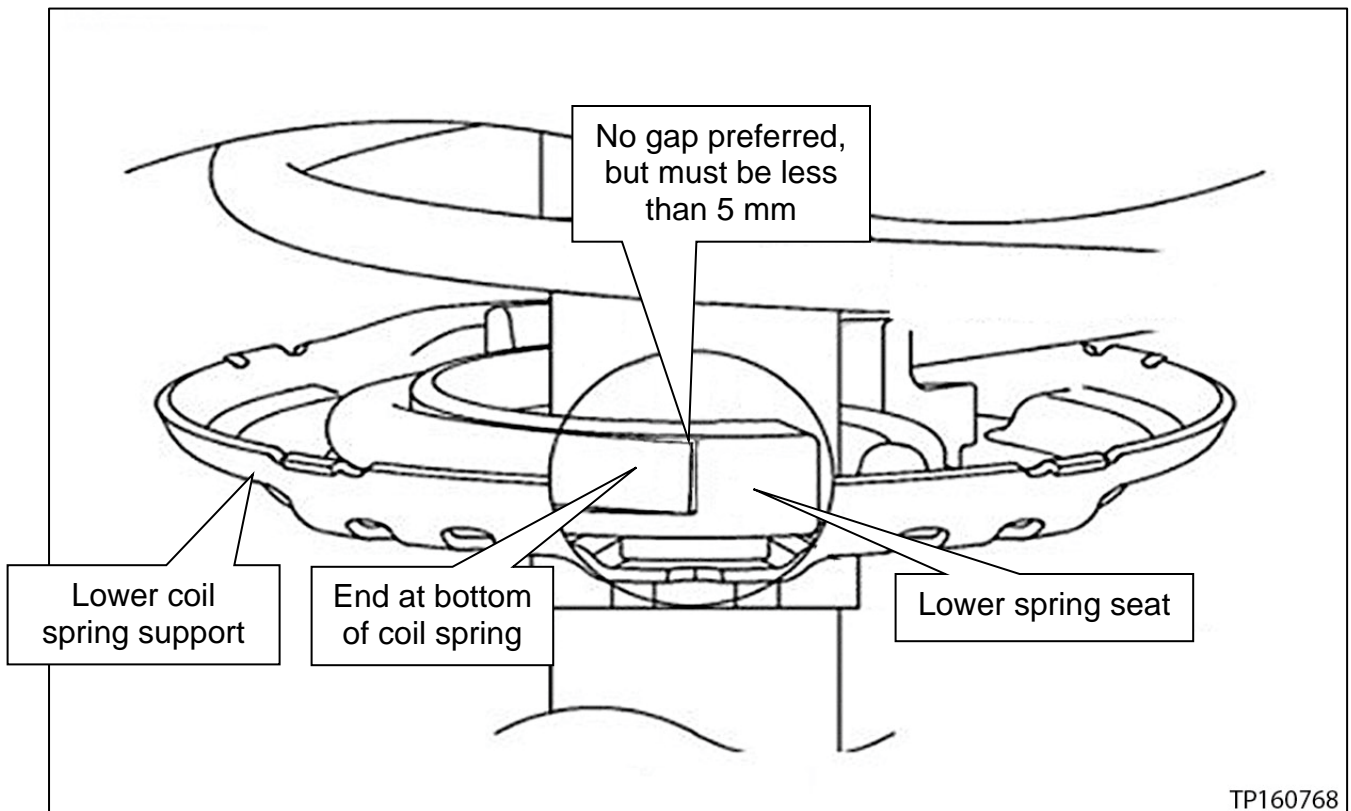

Figure 4

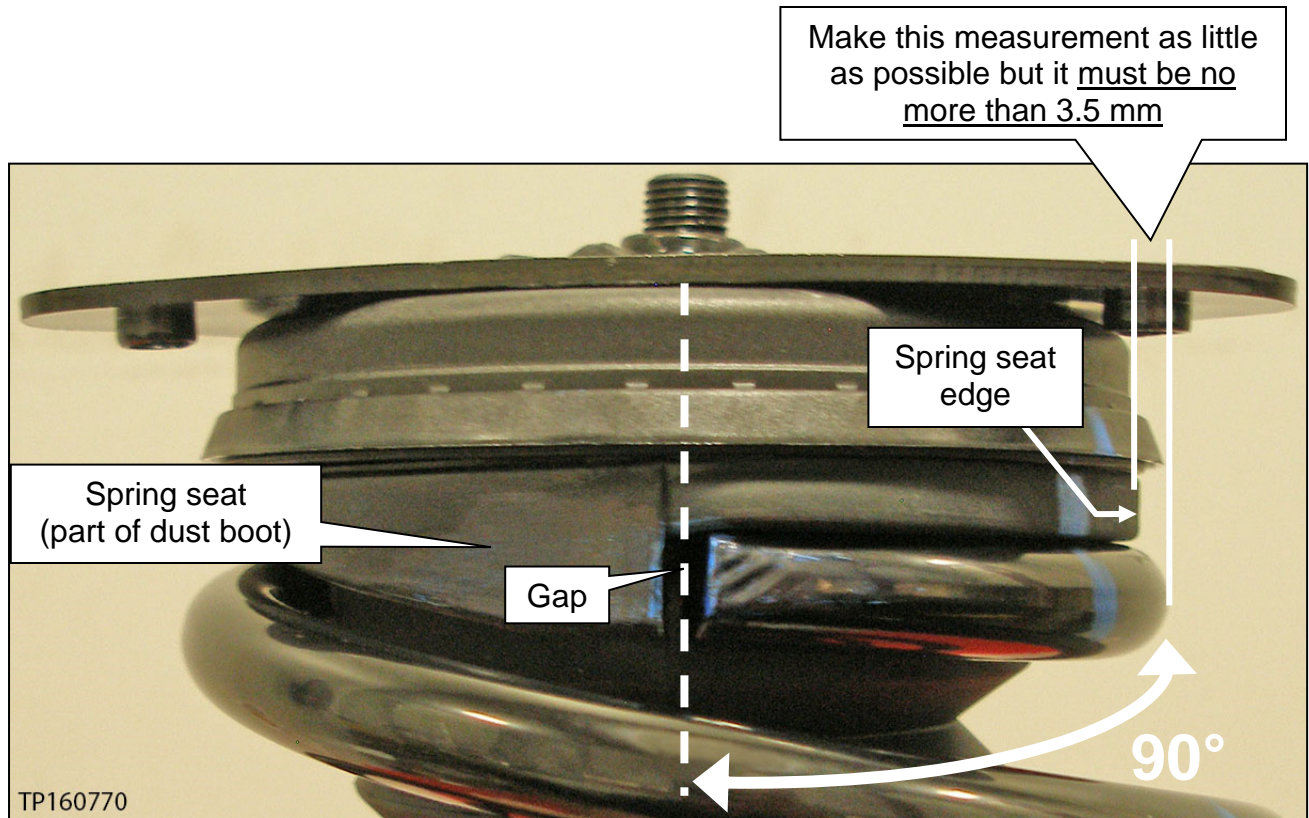

Figure 5

- The side edge of the upper coil spring, located 90° counter clockwise from the gap, needs to be as little as possible but it must be no more than 3.5 mm from the edge of the spring seat (Figure 5).
- If the measurement is greater than 3.5 mm, rotate the coil spring into the spring seat (close the gap).

PARTS INFORMATION

DESCRIPTION	PART NUMBER	QUANTITY
SPRING - FRONT (Front Suspension Spring)	54010-6SA0B	1 per side As needed
BEARING - STRUT MOUNTING (Strut Bearing)	54325-6RA0A	1 per side As needed
SEAL - MOUNTING, SHOCK ABSORBER (Gasket)	55338-6SA0A	1 per side As needed
Nut (Steering Knuckle Nut)	54588-JA060	2 per side As needed
Nut (Strut Top Nut and Stabilizer Connecting Rod Nut)	01223-A2011	2 per side As needed

AMENDMENT HISTORY

PUBLISHED DATE	REFERENCE	DESCRIPTION
April 23, 2024	NTB24-023	Original bulletin published