



# Technical Service Bulletin

## 43 Air suspension system fault - DTC C118D01 Compressor for level control electrical error

43 24 90 2073034/5 May 14, 2024. Supersedes Technical Service Bulletin Group 43 number 24-88 dated May 7, 2024 for reasons listed below.

Model(s)	Year	VIN Range	Vehicle-Specific Equipment
e-tron, and e-tron Sportback	2023	All	Air Suspension
A6, A6 allroad, S6, RS 6 Avant, A7, S7, RS 7, A8, S8, Q5, Q5 e quattro, Q5 Sportback, SQ5, SQ5 Sportback, Q7, SQ7, Q8, SQ8, and RS Q8	2023 - 2025		
Q8 e-tron, Q8 Sportback e-tron, SQ8 e-tron, and SQ8 Sportback e-tron	2024 - 2025		

## Condition

REVISION HISTORY		
Revision	Date	Purpose
5	-	Revised <i>Warranty</i> (Modified Labor Operations) Revised <i>Header</i> (Added Model Year)
4	05/07/2024	Revise <i>Service</i> (Updated Procedure)
3	04/10/2024	Revise <i>Service</i> (Added Note)

### Customer states:

The message "*Air suspension: system fault*" is shown in the instrument cluster.

### Workshop findings:

The following DTC is logged in the suspension control unit -J775- (diagnostic address 0074):

- **C118D01:** Compressor for level control electrical error.

## Technical Background



# Technical Service Bulletin

---

Not applicable.

## Production Solution

Improved software for compressor electronics J1135 is planned.

## Service

The described procedure only applies if compressor electronics with part number index A are fitted in the vehicle (affected part number 4M0.907.778.A) (Figure 1, number 30).



# Technical Service Bulletin

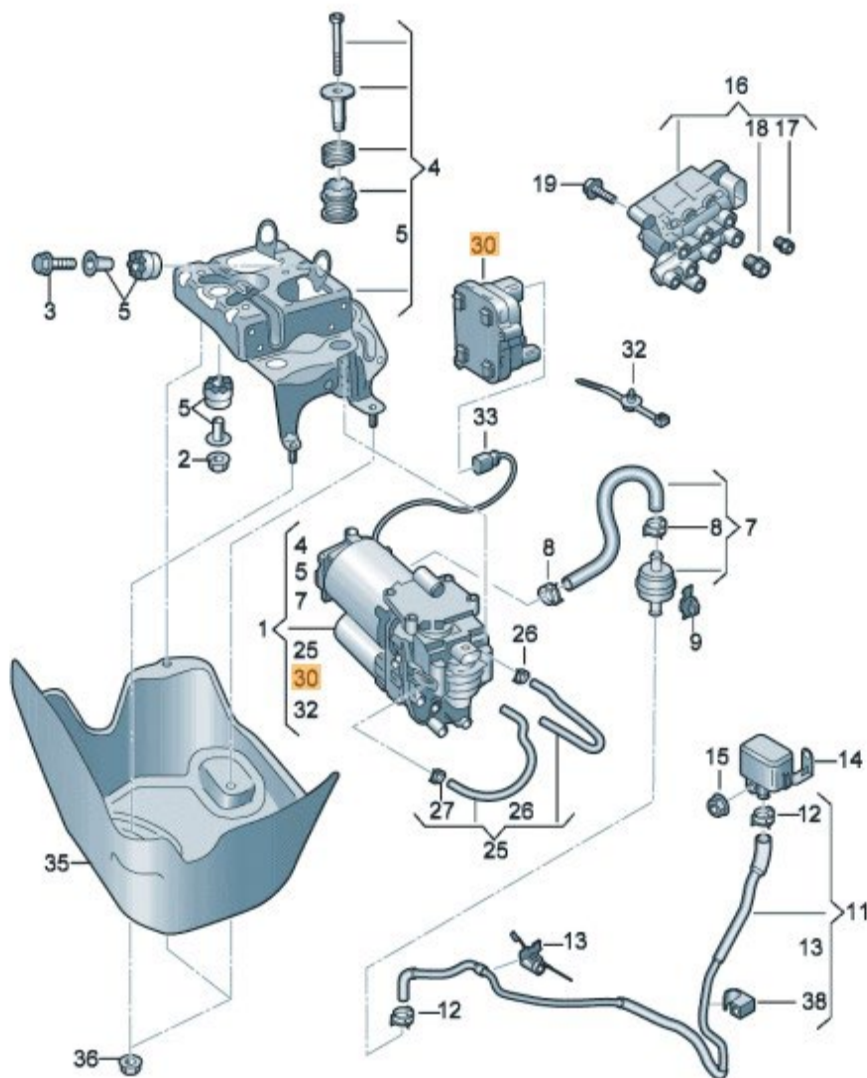

**Figure 1.** Verify that the compressor electronics is part number 4M0.907.778.A.

If no irregularities are found when checking the wiring/contacts at the air compressor and compressor electronics J1135, proceed as follows:

- If the DTC is **passive/intermittent**, delete the DTC.
- If the DTC is logged as **active/static** and remains active/static after the ignition is switched off and then on again, replace the control unit for compressor electronics J1135 (**not the air compressor**).
- Please use part number **4M0.907.778 (Without index A)**.

 **NOTICE**



# Technical Service Bulletin

If the DTC C118D01 is stored for a second time in the J775 as passive/intermittent, replace the J1135.

## Warranty

<b>Claim Type:</b>	<ul style="list-style-type: none"> <li>• 110 Up to 48 Months/50,000 Miles.</li> <li>• G10 for CPO Covered Vehicles – Verify Owner.</li> <li>• If the vehicle is outside of any warranty, this Technical Service Bulletin is informational only.</li> </ul>		
<b>Service Number:</b>	4316		
<b>Damage Code:</b>	0039		
<b>Labor Operations:</b>	Remove and install control unit J1135	4316 19xx	See SRT with associated operations
	Charge battery	2706 8950	See SRT with associated operations
<b>Diagnostic Time:</b>	GFF	0150 0060	Time stated on the diagnostic protocol (Max 50 TU)
	Road test prior to the service procedure	No allowance	0 TU
	Road test after the service procedure	No allowance	0 TU
<b>Claim Comment:</b>	As per TSB 2073034/5		

All warranty claims submitted for payment must be in accordance with the *Audi Warranty Policies and Procedures Manual*. Claims are subject to review or audit by Audi Warranty.

## Required Parts and Tools

The part numbers mentioned in this TSB are different than the ones listed in ETKA. Only use parts listed in this TSB, this includes superseding part numbers!		
Part Number	Part Description	Quantity
See ETKA	Fasteners, Bolts, Nuts, and Screws as needed per the Repair Manual	See ETKA/ELSA
<b>4M0.907.778</b>	Control unit for compressor electronics J1135 (if necessary)	01



# Technical Service Bulletin

---

## Additional Information

All parts and service references provided in this TSB (2073034) are subject to change and/or removal.

©2024 Audi of America, Inc. All rights reserved. The information contained in this document is based on the latest information available at the time of printing and is subject to the copyright and other intellectual property rights of Audi of America, Inc., its affiliated companies, and its licensors. All rights are reserved to make changes at any time without notice. No part of this document may be reproduced, stored in a retrieval system, or transmitted in any form or by any means, electronic, mechanical, photocopying, recording, or otherwise, nor may these materials be modified or reposted to other sites without the prior expressed written permission of the publisher.