



Service Bulletin

Bulletin No.: 18-NA-020

Date: May, 2024

TECHNICAL

Subject: Poor Engine Performance in Extremely Cold Weather Conditions, Malfunction Indicator Lamp (MIL) Illuminated with DTCs P0300, P0299, P0234 and/or P2227 Set

This Bulletin replaces PIP5511A. Please discard PIP5511A.

Brand:	Model:	Model Year:		VIN:		Engine:	Transmission:
		from	to	from	to		
Chevrolet	Equinox	2018	2024	-	-	Equipped with 2.0L or 1.5L Engine (RPOs LTG, LYX, LSD)	All
GMC	Terrain						

Involved Region or Country	United States and Canada
Condition	Some customers may comment on a Malfunction Indicator Lamp illuminated or a reduced power complaint. During diagnosis, a technician may find DTC P0300, P0299, P0234 and/or P2227 set or stored.
Cause	This condition may be caused by a moisture build up inside the charge air cooler (CAC). This condition is more likely on the smaller displacement engines where an air-to-air charge air cooler is used. In cold temperatures, ambient and PCV moisture can freeze in the charge air cooler, restricting flow, and causing DTC P0299 and/or P2227, or P0300.
Correction	The correction required will be based on the build of the vehicle, previous repairs that may have been made, and the operating conditions. Use the chart to determine which repair is required. The more severe the cold weather driving conditions, the more operations may need to be implemented. Blocking cold air from the CAC is the main objective to help prevent the moisture from freezing. Note: In rare cases where the addition of a charge air cooler shutter doesn't prevent CAC freezing, install the lower portion of the soft grill cover. Inform the customer to remove the cover from the grill when temperatures are consistently averaging 32F/0C or above. Note: Frozen oil/water condensate contaminant in the Turbocharger Wastegate Regulator Solenoid Valve (TCV) is often concurrent with vehicle operation conditions that cause CAC freezing. If DTC P0234 is set - Turbocharger Wastegate Regulator Solenoid Valve Inspection. Important: The DTCs and symptoms above are not exclusively related to freezing/icing conditions. Only follow this bulletin when the condition is directly correlated with extreme cold -18°C (0°F) or less. System leaks should always be ruled out first for P0299. During the visual inspection, do a pull-push check on all quick connectors to ensure they are properly connected. Signs of moisture will always be present in the CAC system and are not a reliable indicator of freezing/icing. Important: For additional information on Oil/Moisture Condensate Freezing Up in the Turbocharger Wastegate Regulator Solenoid Valve, refer to Service Procedure (Part 1). Important: Look at the shutter through the lower grill opening to make sure it is not being restricted by debris such as grass or insects. An obstruction will prevent the shutter from operating correctly in both cold and warmer temperatures, decreasing its effectiveness in cold weather, and hindering engine performance in warmer temperatures. Instruct the vehicle owner to periodically check the shutter and spray it off to keep it clean and performing as intended.

Important: Service agents must comply with all International, Federal, State, Provincial, and/or Local laws applicable to the activities it performs under this bulletin, including but not limited to handling, deploying, preparing, classifying, packaging, marking, labeling, and shipping dangerous goods. In the event of a conflict between the procedures set forth in this bulletin and the laws that apply to your dealership, you must follow those applicable laws.

Note: If the charge air cooler is not leaking, but is frozen and/or contaminated, remove, thaw, wash it out and reinstall. Use labor operation 4087008 (Add - Cleaning and Reinstalling Charge Air Cooler if Frozen and/or Contaminated). If there is a shutter already installed, spray it off while it is removed for the charge air cooler thaw and rinse operation.

Important: **DO NOT** replace the CAC inlet or outlet ducts as part of this repair unless there is evidence of damage and/or a leak from either CAC duct.

Service Procedure - Charge Air Cooler Diagnosis

Part 1

Inspect the Turbocharger Control Valve (TCV) to ensure it is not frozen.

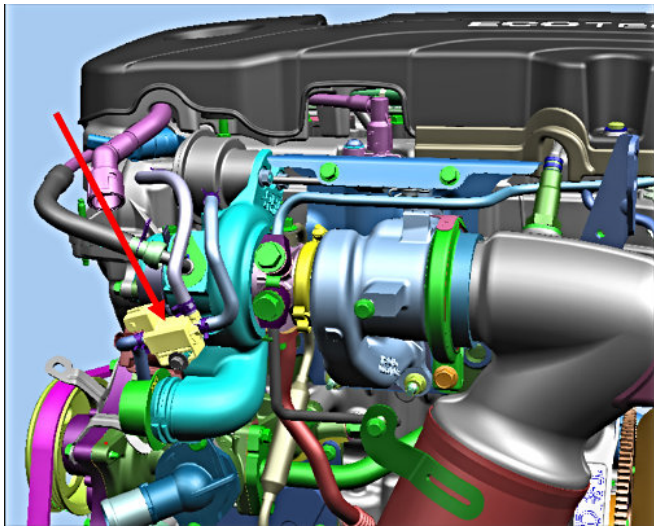

6055063

1. Remove Turbocharger Wastegate Regulator Solenoid Valve.
2. Drain Turbocharger Wastegate Regulator Solenoid Valve (TCV) by turning valve upside down.

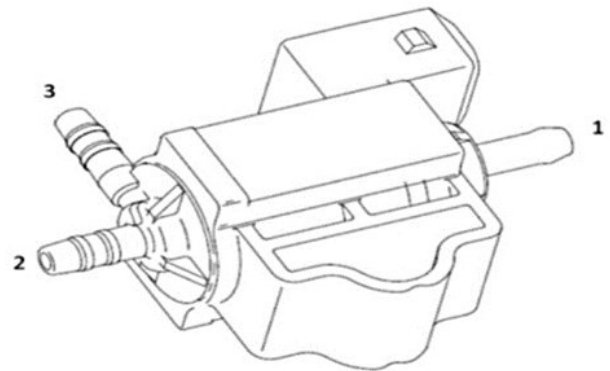

6055068

3. Using clean shop air regulated to 80-100 PSI (551-689 kPa), blow through all three ports (1, 2 & 3) for 5 seconds each. Repeat this step twice.

Note: Check port #2 to assure the spring gets lifted off the seat. This will be determined by the compressed air not dead heading when applied to port #2. When applying air to this port a small amount of air should be observed at port #3 and even less air will be noticed at port #1. If this does not happen, the TCV plunger may have hardened deposits from hot operating conditions which will impede TCV plunger movement, and the Turbocharger Wastegate Regulator Solenoid Valve should be replaced.



6055077

4. Prior to reinstalling the TCV, pre-position the thermal wrap, as shown in the picture above. This will aid in installation of the wrap once the TCV is reinstalled.



6055079

- This is an off-car view of the wrap installed on the TCV and is representative of what final installation should look like. The snap can NOT be completed prior to installing the mounting bolt
5. Reinstall Turbocharger Wastegate Solenoid Valve (TCV) using the latest service information.

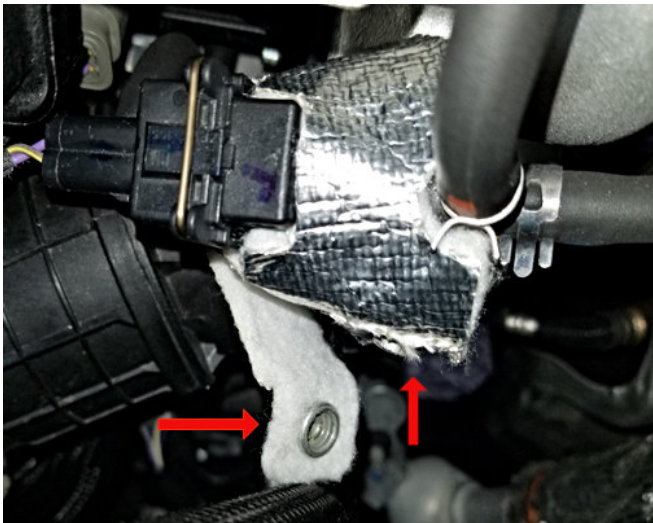

6055084



6055111

6. Once the mounting bolt and hoses are properly installed, pull the lower portion of the wrap upward, and snap it into position
7. Clear all DTC's using GDS and evaluate
8. Continue to Part 2.

Important: Remove the boost sensor and wipe with a clean rag to remove residual moisture to ensure the sensor is not contaminated. DO NOT use chemical cleaners.

Part 2

1. Perform a smoke leak test of the charge air cooler, using essential tool GE-52250 Power Smoke Diagnostic Leak Detector.

Refer to Chart Based Conditions, below, for next steps.

Chart Based Conditions						
Model Years	Condition	Replace Charge Air Cooler – (CAC) Refer to Charge Air Cooler Replacement on SI.	Remove Front Bumper Secondary (lower) Shutter	Install Front Bumper Lower (CAC) Shutter, instructions below	Install Soft Grill Cover Over Lower Grill Opening***	Repair Other System Issue
2018-2022	CAC Leaking ONLY	X	-	-	-	-
2018	CAC Frozen (Built Before March 1, 2018) *	X	X	X	Temperature Averages are BELOW 32F/0C **	-
2018-2020	CAC Frozen (Built After March 1, 2018) *	-	X	X	Temperature Averages are BELOW 32F/0C **	-
2018-2020	CAC Frozen & Leaking	X	X	X	Temperature Averages are BELOW 32F/0C **	-
2018-2024 (Already had CAC shutter installed)	CAC Frozen AFTER removal of Front Bumper Secondary (lower) Shutter AND Installation of Front Bumper Lower (CAC) Shutter	-	-	-	Temperature Averages are BELOW 32F/0C **	-
2021-2024 (Has not had CAC shutter installed)	CAC Frozen (Without RPO VRI)	-	X	X	Temperature Averages are BELOW 32F/0C **	-
2021-2024	CAC Frozen & Leaking (Without RPO VRI)	X	X	X	Temperature Averages are BELOW 32F/0C **	-
2021-2024	CAC Frozen (With RPO VRI)	-	-	-	Temperature Averages are BELOW 32F/0C **	-
2021-2024	CAC Frozen & Leaking (With RPO VRI)	X	-	-	Temperature Averages are BELOW 32F/0C **	-
2018-2024	P0299 or P0234 Or CAC Frozen (with or without VRI) (LYX /LSD ONLY)	-	-	-	-	Engine Control Module Re-programming with SPS (2018-2024) and Install TCV Thermal Wrap (2018-2022)
2018-2021	P0299 or P0234 Or CAC Frozen (with or without VRI) (LTG)	-	-	-	-	Install TCV Thermal Wrap
2018-2024	CAC Not Frozen or Leaking and P0299 Still Set	-	-	-	-	Refer to SI

Chart Based Conditions						
Model Years	Condition	Replace Charge Air Cooler – (CAC) Refer to Charge Air Cooler Replacement on SI.	Remove Front Bumper Secondary (lower) Shutter	Install Front Bumper Lower (CAC) Shutter, instructions below	Install Soft Grill Cover Over Lower Grill Opening***	Repair Other System Issue

Note: The Engine Control Module calibration should be updated (LYX/LSD ONLY). The new calibration will enable a revised transmission shift pattern during cold weather operation which does not use overdrive as frequently. As a result, some customers may notice elevated engine RPM's during highway operation. This operating mode will reduce the potential for ice to build up inside the charge air cooler, and the potential for setting P0299 or P0234 diagnostic codes. The customer must be informed by dealership personnel by explaining the new engine control module calibration and its effect on transmission shift patterns at highway speeds during cold weather to avoid a customer return to the dealership after programming is completed.

Note: Replacement of the Charge Air Cooler is ONLY required if GM IVH (View Vehicle Build) indicated build date is before 03/01/2018 AND GM IVH (View Transaction History Detail) indicates the CAC has not been previously replaced.

** Remove Soft Grill Cover Over Lower Grill Opening when temperatures are consistently averaging 32F/0C or above.

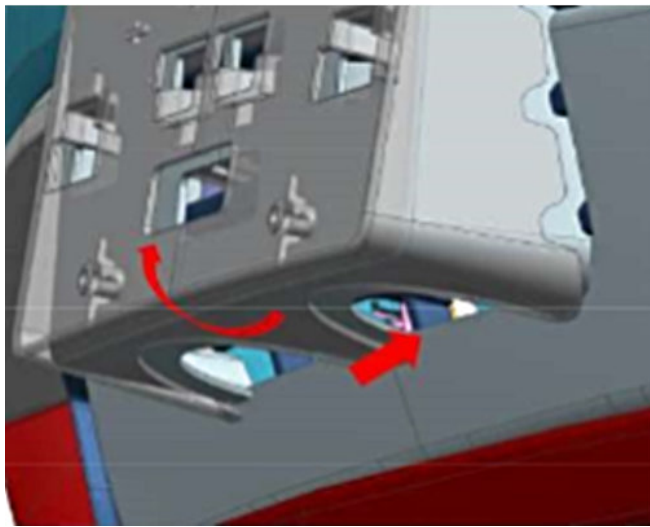

*** For Terrains with front license plate bracket (VK3), install tape over the openings on bottom of the license plate bracket, to prevent airflow from bypassing the grill cover and flowing directly at the charge air cooler, as shown in the picture above.

5775941

Examples of the Differences Between the Shutter Systems

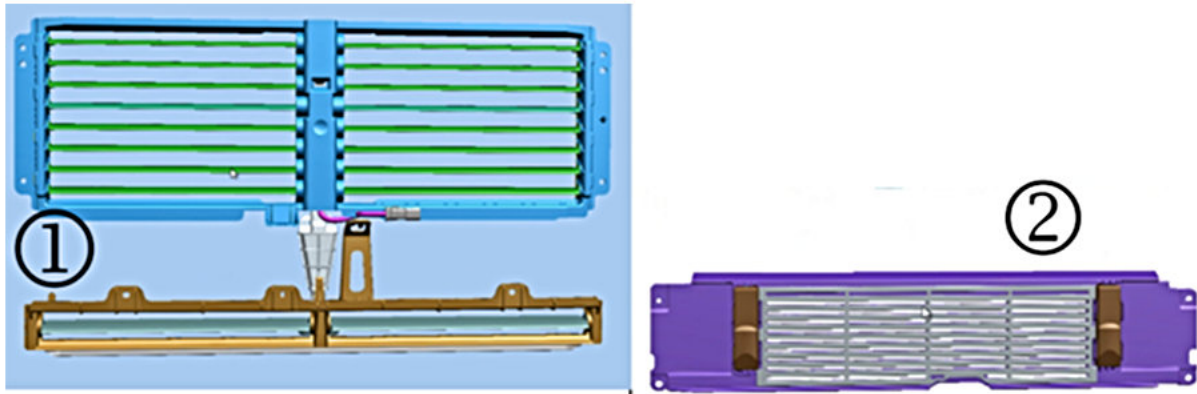

- Front Bumper Upper Shutter with the Front Bumper Secondary (lower) Shutter attached (1), as shown in the picture above.
- Front Bumper Lower Shutter that mounts in the front of Charge Air Cooler (2), as shown in the picture above.

Service Procedure - Install Front Bumper Lower (CAC) Shutter

Important: The Front Bumper Lower (CAC) Shutter is a permanently retrofitted item. The added shutter is activated to close and open based on temperature, controlled by integral thermostatic springs.

Note: Advise the customer to keep the shutter clear of debris, including leaves and insects. The shutter should be periodically cleaned with a soapy water spray, especially right before the cold weather season begins.

1. Remove the Front Bumper Upper Shutter for modification. Refer to *Front Bumper Shutter Replacement* in SI.
2. Remove and discard the front bumper secondary (lower) shutter assembly from the upper shutter. Refer to *Front Bumper Secondary Shutter Replacement* in SI.

Note: The secondary (lower) shutter assembly will NOT need to be reinstalled in the future.

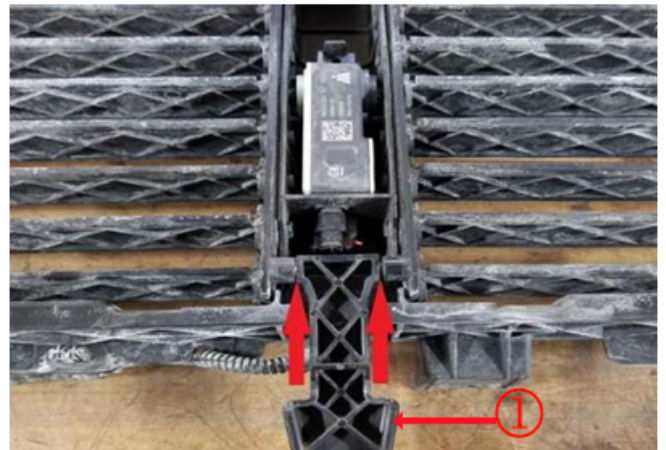

5736482

3. On the back of the now removed upper shutter, using a saw blade, cut the upper shutter to secondary (lower) shutter actuator at the pivot location, as shown in the picture above. Remove the linkage (1) and discard.
4. Reinstall the upper shutter.

5279924

5. Remove and discard the 4 Lower Air Baffle push-in retainers (1), as shown in the picture above.

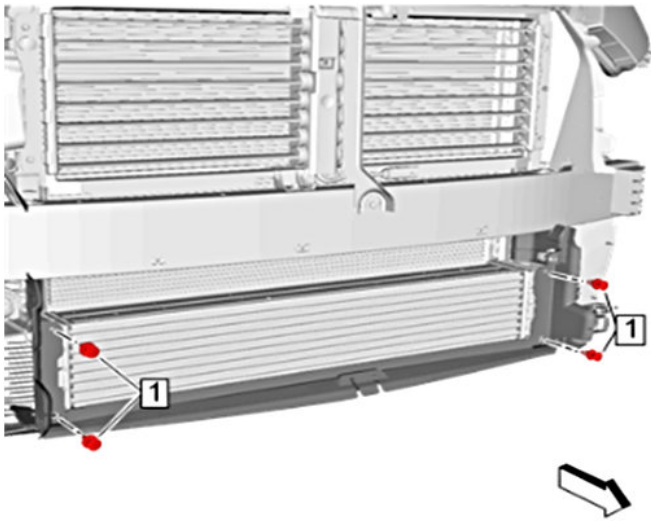

5775942



5775943

6. Locate Front Bumper Lower (CAC) Shutter in front of the lower air baffle and install the new, longer retainers, as shown in the picture above.
7. Continue reinstalling the parts that were removed during disassembly as part of *Front Bumper Shutter Replacement* in SI.

Examples of the Grill Opening Covers (Installation instructions included in the part packaging)

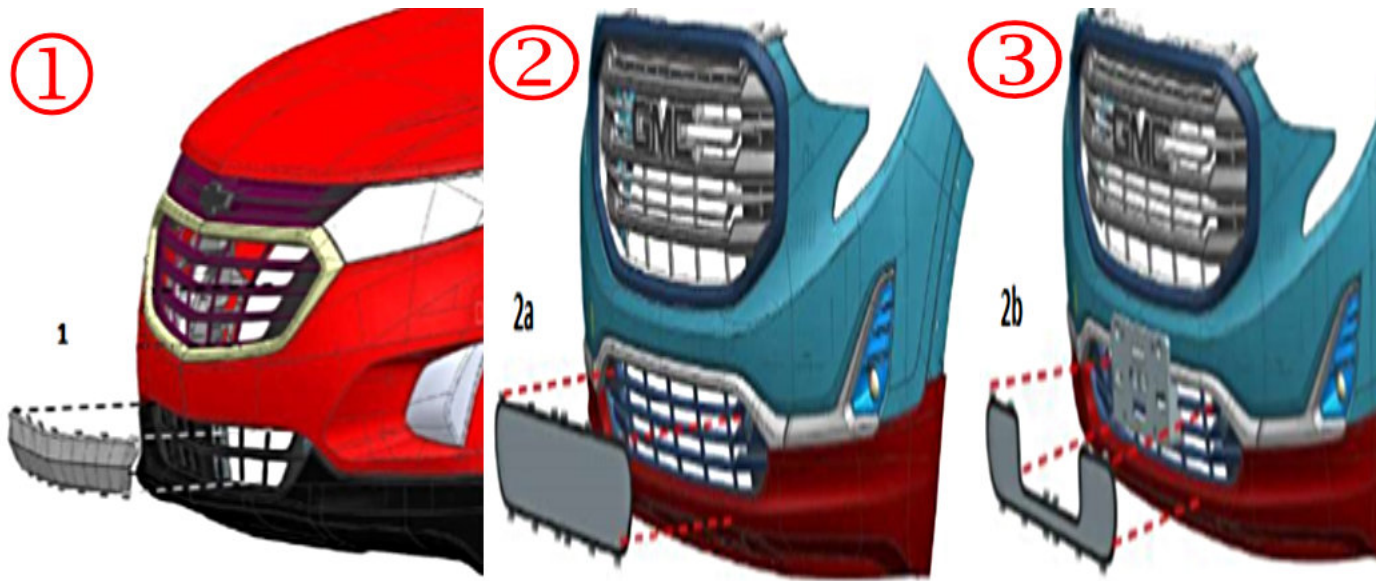

5776421

Shown in the picture above are examples of the grill opening covers for the Equinox (1), Terrain without (RPO VK3) (2) and Terrain with (RPO VK3) (3).

Parts Information

Causal Part	Description	Part Number	RPO
X	Charge Air Cooler	85163204	LYXLSD
		85163205	LTG

Causal Part	Description	Part Number	RPO
NA*	COVER PKG-FRT GRL OPG	2018-2021 84624274 (Equinox)	Without WBL or WFP
		2018-2021 84624275 (Equinox with Red- line/Sport or acces- sory grill PDV)	With WBL or WFP or accessory grill PDV
		2018-2021 84630081 (Terrain without front license plate bracket)	Without VK3
		2018-2021 84648360 (Terrain with front license plate bracket)	With VK3
		2022-2024 85551501 (Equinox, except RS)	Without B8G
		2022-2024 85551504 (Equinox RS)	With B8G
		2022-2024 8555139 (Terrain, except Denali, with front license plate bracket)	With VK3
		2022-2024 8555142 (Terrain, except Denali, without front license plate bracket)	Without VK3
		2022-2024 85576446 (Terrain Denali, with license plate bracket)	With VK3
		2022-2024 85576448 (Terrain Denali, without front license plate bracket)	Without VK3

Causal Part	Description	Part Number	RPO
	SHUTTER KIT - FRT BPR LWR (CAC Shut- ter)	2018-2021 85139401 (Equinox)	LTG, LYX
		2018-2021 85139400 (Terrain)	
		2022-2024 85139402 (Equinox)	LYX/LSD
		2022-2024 85139403 (Terrain)	
	RETAINER, FRT BPR SHUTTER BFL	11589291 x 4	
TCV THERMAL WRAP	25205589	2018-2022 LYX	

*For warranty transactions, **DO NOT** mark this/these parts as the Causal Part. Enter the word "Bulletin" in the Causal Part Description free-flow text field.

Warranty Information

For vehicles repaired under the Powertrain coverage, use the following labor operation. Reference the Applicable Warranties section of Investigate Vehicle History (IVH) for coverage information, except ECM reprogramming is covered for 8 years/80,000 miles (U.S.) or 8 years/130,000 km (Canada).

Important: Warranty coverage code E2 applies for this module programming event. ECM reprogramming is covered for 8 years/80,000 miles (U.S.) or 8 years/130,000 km (Canada).

Labor Operation	Description	Labor Time
4088408*	Charge Air Cooler Replacement	2.0 hrs. (Equinox RPO LTG)
		2.1 hrs. (Equinox RPO LYX/LSD)
		2.0 hrs. (Terrain RPO LTG)
		2.1 hrs. (Terrain RPO LYX/LSD)
Add	Cleaning and Reinstalling Charge Air Cooler if Fro- zen and/or Contaminated	1.0 hrs. (Equi- nox, Terrain)
Add	Install Shutter Cover if also Replacing Charge Air Cooler	0.2 hrs. (Equi- nox, Terrain)
Add	Perform Smoke Test	0.3 hr
1086798*	Install Charge Air Cooler Grille Cover	0.3 hrs. (Equi- nox)
		0.2 hrs. (Terrain)
4088418*	Install Shutter Cover	1.0 hrs. (Equi- nox, Terrain)

Labor Operation	Description	Labor Time
Add	Engine Control Module Re-programming with SPS, Removal of condensation from Turbocharger Wastegate Regulator Solenoid Valve and Install Thermal Wrap	1.0 hrs. (Equinox, Terrain)
*This is a unique Labor Operation for Bulletin use only.		

Version	26
Modified	<p>Released January 22, 2018</p> <p>Revised July 26, 2018 – Added Holden Equinox Model.</p> <p>Revised October 19, 2018 – Updated the Cause and Correction.</p> <p>Revised December 21, 2018 – Updated Additional Options, Correction, Parts Information and Warranty Information.</p> <p>Revised January 09, 2019 – Updated the Parts Information.</p> <p>Revised February 19, 2019 – Added Envision also updated the Condition, Parts Information and Warranty Information.</p> <p>Revised March 19, 2019 – Updated the Service Procedure and Warranty Information for Equinox/Terrain.</p> <p>Revised May 15, 2019 – Updated the Warranty Information and adding flow chart.</p> <p>Revised November 05, 2019 – Updated the Warranty Information.</p> <p>Revised December 17, 2019 – Added 2020 Model Year.</p> <p>Revised February 21, 2020 – Updated pictures for flow charts, also updated applicable information within the bulletin including the Service Procedure Equinox/Terrain also Part and Warranty Information.</p> <p>Revised April 07, 2020 – Updated information for the following: Correction, Service Procedure (Equinox/Terrain) and Warranty Information.</p> <p>Revised February 11, 2021 – Added 2020-2021 Model Years for Equinox/Terrain, added Examples of the Difference Between the Two Shutters information and updated information under Service Procedure Equinox, Terrain.</p> <p>Revised March 18, 2021 - Removed Buick Envision and updated applicable information throughout the Bulletin.</p> <p>Revised January 21, 2022 – Added 2022 Model Year and updated information under Condition, Chart Based Conditions Table, Part Information and Warranty Information.</p> <p>Revised January 28, 2022 – Updated the Warranty Coverage.</p> <p>Revised February 10, 2022 – Updated information under Service Procedure - Charge Air Cooler Diagnosis, Chart Based Conditions, Part Information and Warranty Information.</p> <p>Revised May 24, 2022 – Updated information under Subject, Service Procedure - Charge Air Cooler Diagnosis, Chart Based Conditions, Part and Warranty Information.</p> <p>Revised August 25, 2022 – Added 2023 Model Year, RPO LSD and updated information under Correction, note above the Service Procedure, Chart Based Conditions and Parts Information.</p> <p>Revised December 14, 2022 - Updated the Warranty Information.</p> <p>Revised January 19, 2023 - Updated Note above Service Procedure - Charge Air Cooler Diagnosis and information in Chart Based Conditions and Warranty Information.</p> <p>Revised February 08, 2023 - Updated the Parts Information.</p> <p>Revised October 19, 2023 - Added 2024 Model Year, Important Statement, and updated the Chart Based Conditions.</p> <p>Revised November 09, 2023 - Added 2018–2021 LTG Information to Chart Based Conditions.</p> <p>Revised February 15, 2024 - Added E2 Information to Warranty section.</p> <p>Revised May 30, 2024 - Updated Subject, Added Important Statement to Correction section, Updated Warranty Information section.</p>

