



# Service Bulletin

Bulletin No.: 22-NA-165

Date: May, 2024

## TECHNICAL

**Subject: Brake Squeal Noise at Low Speeds (Pursuit Rated Option)**

Brand:	Model:	Model Year:		VIN:		Engine:	Transmission:
		from	to	from	to		
Chevrolet	Silverado 1500	2023	2025				
	Tahoe PPV	2021					

<b>Involved Region or Country</b>	North America
<b>Additional Options (RPOs)</b>	Equipped with Police Vehicle Package RPO 9C1
<b>Condition</b>	Some customers may comment on loud brake squeal noise at low speeds.
<b>Cause</b>	<p>This condition may be caused by a pursuit rated pad material that may be noisy at low speeds.</p> <p>Some vehicles may not need a pursuit rated pad, those used for surveillance or non-patrol vehicles. For these vehicles, there is a quieter brake pad/rotor option available. The quieter brake pads/rotors have not been certified as pursuit rated.</p> <p><b>There is now a pursuit rated option that has better noise characteristics. These should be used with the OEM rotors.</b></p>
<b>Correction</b>	<p>Replace the front and rear pads and rotors with new design parts (non-pursuit rated) <b>OR</b> replace the pads only using the OEM rotors when using the AC Delco pads (pursuit rated).</p> <p><b>Important:</b> Copper paste lubricant must be used when installing these pads.</p>

### Service Procedure

**Important: Service agents must comply with all International, Federal, State, Provincial, and/or Local laws applicable to the activities it performs under this bulletin, including but not limited to handling, deploying, preparing, classifying, packaging, marking, labeling, and shipping dangerous goods. In the event of a conflict between the procedures set forth in this bulletin and the laws that apply to your dealership, you must follow those applicable laws.**

If you encounter a vehicle with the above concern, replace the front and rear pads and rotors. Refer to *Front and Rear Brake Rotor Replacement* in SI.

### Pursuit Rated Brake Pad Option

AC Delco has released brake pads that are pursuit rated and do have better noise characteristics than the

OEM pursuit brake pads. Refer to the additional steps when installing the pursuit rated brake pads:

**Note:** These brake pads should be used with the OEM rotors.

1. Clean the caliper interface to remove any debris, dirt, dust, or original grease that may have attached.

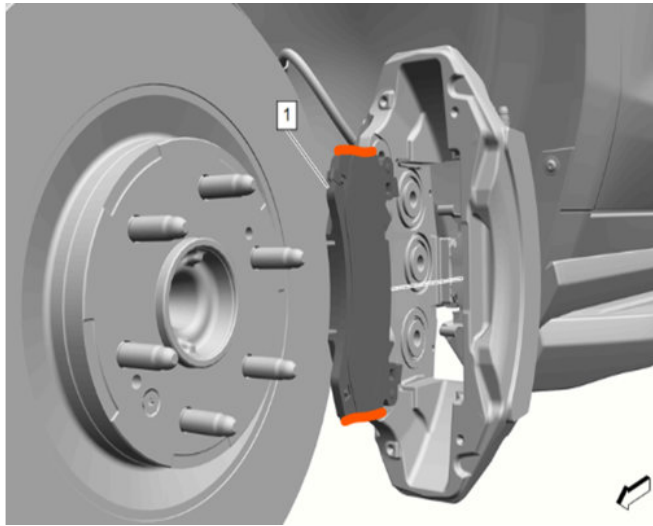

6581016

- Apply approximately 0.09-0.15 g (0.003-0.005 oz) of copper past PN# 19303310 (PN# 19303311 Canada) or equivalent on the brake pad abutments (1), as shown in the picture above, which contacts the brake caliper.

**Important: DO NOT** get any copper paste (grease) on the friction face, **OR** any of the rubber components of the caliper, **OR** on the back of the brake pad.

- Use 3M Scotch-Brite (3M) pad or equivalent to prepare the rotor surface for burnishing.

**Burnish Procedure**

- Make 10 stops from 72 km/h (45 mph) (or a safe speed depending on posted speed limit) at 0.5g (edge of wheel lock) with 0.2-mile cooling intervals in between.
- Make 2 stops from 80-96 72 km/h (50-60mph) (or a safe speed depending on posted speed limit) at 0.5g (edge of wheel lock) no cooling in between.

- Cool – Drive for 5 min at 64 km/h (40 mph) with no stops.
- Make 10 stops from 72 km/h (45 mph) at 0.3g decel (normal deceleration as one would be exiting a freeway) at 0.2-mile cooling in between.

**Parts Information**

Causal Part	Description	Part Number	Qty
N/A	PAD KIT, FRT DISC BRK	87866865 (not pursuit rated)	1
	ROTOR, FRT BRK (CTD)	84879622 (not pursuit rated)	
	PAD KIT, RR DISC BRK	85140320 (not pursuit rated)	
	ROTOR, RR BRK (CTD)	13542117 (not pursuit rated)	
	PAD KIT, FRT DISC BRK (AC Delco)	19468210 (pursuit rated)	
	PAD KIT, RR DISC BRK (AC Delco)	19468206 (pursuit rated)	

**Warranty Information**

For Vehicles Brake Pads/Linings are covered by the New Vehicle Limited Warranty for up to 7,500 miles (12,000 kilometers in Canada); any replacement after 7,500 miles (12,000 kilometers in Canada) is considered maintenance and is not covered as part of the New Vehicle Limited Warranty.

Labor Operation	Description	Labor Time
2486288*	Front and Rear Brake Pad and Rotor Replacement	2.1 hr.
2486178*	Front and Rear Brake Pad Replacement and Burnish	2.1 hr.

\*This is a unique Labor Operation for Bulletin use only.

<b>Version</b>	7
<b>Modified</b>	Released May 17, 2023 Revised November 22, 2023 - Added 2024 Model Year and updated the Cause and Correction. Revised March 20, 2024 - Added AC Delco brake pad P/N#, Pursuit Rated Brake Pad Option and Burnish Procedure. Revised April 05, 2024 — Updated the Warranty Information. Revised April 18, 2024 - Updated the Correction. Revised May 03, 2024 - Added 2023 - 2024 Silverado 1500 Revised May 14, 2024 — Added 2025 Model Year and updated the Part Information.

