



STAR ONLINE PUBLICATION



Case Number: S2223000044 Rev. B

Release Date: May 2024

Symptom/Vehicle Issue: Power Side Steps Reverse, Stop In Motion, Do Not Deploy Or Stow, And May Have a Chirp Noise.

Customer Complaint/Technician Observation: Power side steps fail to operate, may stop or auto reverse direction when operating. The customer may also describe grinding or chirping type noises during side step operation.

Discussion: Prior to any repair of the PSS (Power Side Step) inspect the assembly for excessive dirt accumulation. Cleaning and lubricating the PSS may resolve the condition. Follow the below steps prior to replacement of any parts.

1. Fully deploy the running boards. The manual deployment can be done on the radio touch screen as described in the vehicle's Owner's Manual.

<<<**Note**>>> If the running boards will not fully deploy, provide hand assistance to the PSS. Extend the running board by hand by placing downward force on the running board as it deploys. Similarly, if running boards will not fully stow, retract running boards by hand placing upward force on the running board as it stows.

2. Inspect the pivots and linkage of the PSS. If there is dirt/debris buildup, clean between the links and bushing ends/tracks using high-pressure water. The use of a car wash wand is best to prevent excessive water pressure from damaging nearby components. See Fig 1

This document does not authorize warranty repairs. This communication documents a record of past experiences. STAR Online does not provide any conclusions about what is wrong with the vehicle. Rather, it captures all previous cases known that appear to be similar or related to the vehicle symptom / condition. You are the expert, and you are responsible for deciding on the appropriate course of action.

Contact STAR Center, or your Technical Assistance Center Via TechCONNECT or eCONTACT ticket if no solution is found



STAR ONLINE PUBLICATION



Fig 1

Before and after pressurized water cleaning

3. Use a Penetrating spray like MP-50 MOPAR Rust Prevention Lubricant 04549626AD and continue to clean the bushing/pivot locations of both running boards. This will help remove any embedded corrosion/debris that pressure washing may not have removed. If any leftover corrosion/debris is present after using the penetrating spray, perform step 2 again followed by step 3 until corrosion/debris is completely removed from the pivots.
4. Use compressed air to dry the surfaces and remove further debris from the pivots and linkage.
5. Once clean and dry, cycle (extend and retract) the PSS 5 to 10 times to verify operation.
6. Apply MOPAR Spray White Lithium Grease 04318066AE to the pivot points (Fig 2 and 3). Remove excess lubricant with a shop towel. Deploy and retract the PSS 5 to 10 times.

This document does not authorize warranty repairs. This communication documents a record of past experiences. STAR Online does not provide any conclusions about what is wrong with the vehicle. Rather, it captures all previous cases known that appear to be similar or related to the vehicle symptom / condition. You are the expert, and you are responsible for deciding on the appropriate course of action.

Contact STAR Center, or your Technical Assistance Center Via TechCONNECT or eCONTACT ticket if no solution is found



STAR ONLINE PUBLICATION



Fig 2

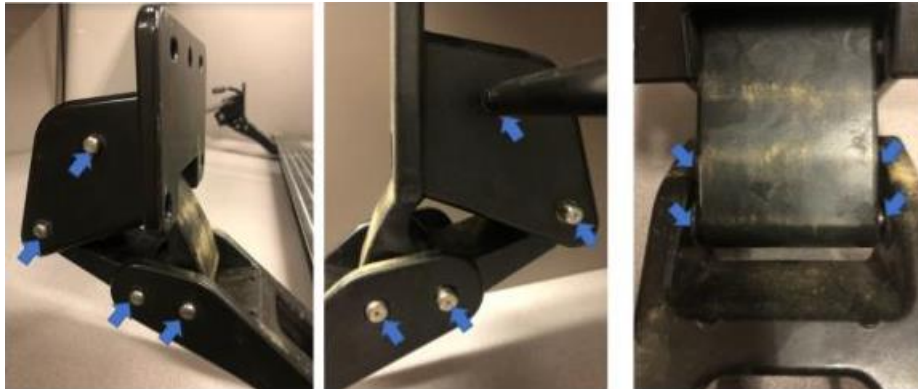

Fig 3
Pivot points (16 per side step)

This document does not authorize warranty repairs. This communication documents a record of past experiences. STAR Online does not provide any conclusions about what is wrong with the vehicle. Rather, it captures all previous cases known that appear to be similar or related to the vehicle symptom / condition. You are the expert, and you are responsible for deciding on the appropriate course of action.

Contact STAR Center, or your Technical Assistance Center Via TechCONNECT or eCONTACT ticket if no solution is found



STAR ONLINE PUBLICATION



7. If power washing and lubrication does not correct the concern, the power running boards can be realigned to the body if they are still binding during deployment. To accomplish this, loosen the mounting bolts allowing the running board to free float and relax. Once the running board is in the desired position, tighten following the torque sequence. Attachment nut torque is 18 N·m (13 Ft. Lbs.).

- 1 Rear upper attachment, 4-way locator
- 2 Front upper attachment, 2-way locator
- 3, 4, 5, 6 Lower attachment, clearance hole

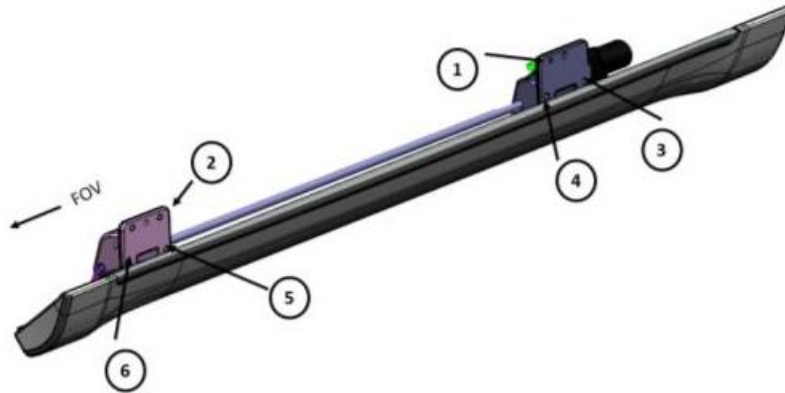

This document does not authorize warranty repairs. This communication documents a record of past experiences. STAR Online does not provide any conclusions about what is wrong with the vehicle. Rather, it captures all previous cases known that appear to be similar or related to the vehicle symptom / condition. You are the expert, and you are responsible for deciding on the appropriate course of action.

Contact STAR Center, or your Technical Assistance Center Via TechCONNECT or eCONTACT ticket if no solution is found