

11 Liter Engines - Fuel In Oil

Published 2 May 2024

Valid for all vehicles built with a 11L engine

Vehicles built with an 11 liter engine may experience a complaint of excessive fuel in the oil. It is possible that the source of the fuel is the rear fuel galley plug in the cylinder head. A new and improved fuel galley plug has been developed to resolve this issue.

The presence of fuel in the oil may be accompanied by report of hard start, which would indicate a loss of pressure in the fuel system when the engine is not running.

The location of the plug can be seen in the image below:

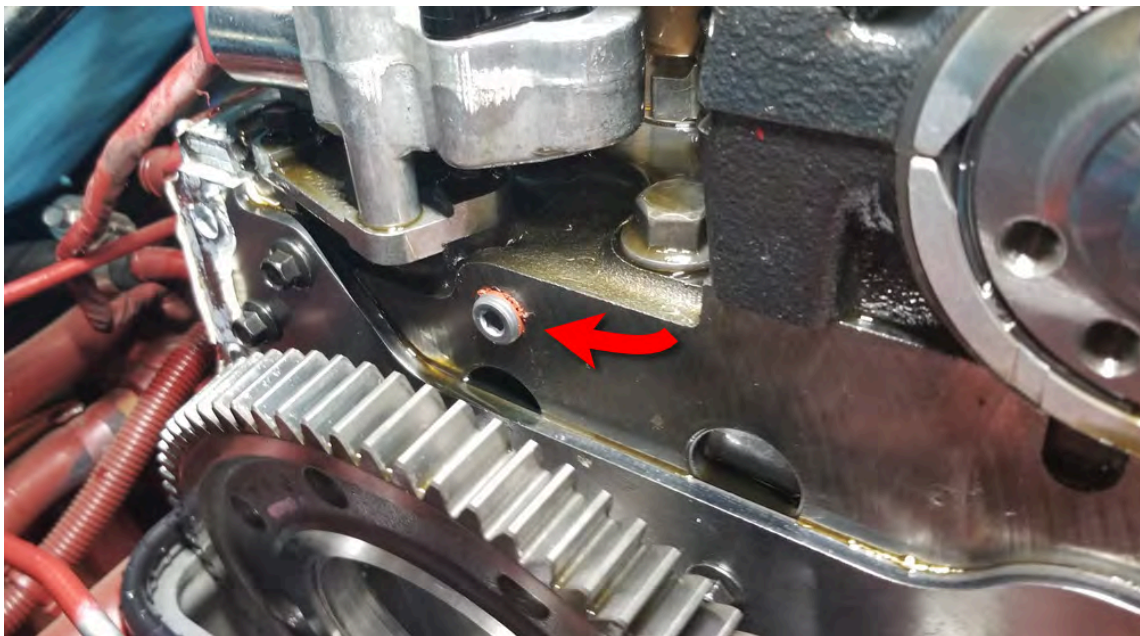

Parts

Part Number	Description	Quantity
945065	Plug	1

Diagnose

1. Remove the valve cover.
2. Add appropriate UV reactive dye to the secondary fuel filter by removing, then reinstalling the filter.

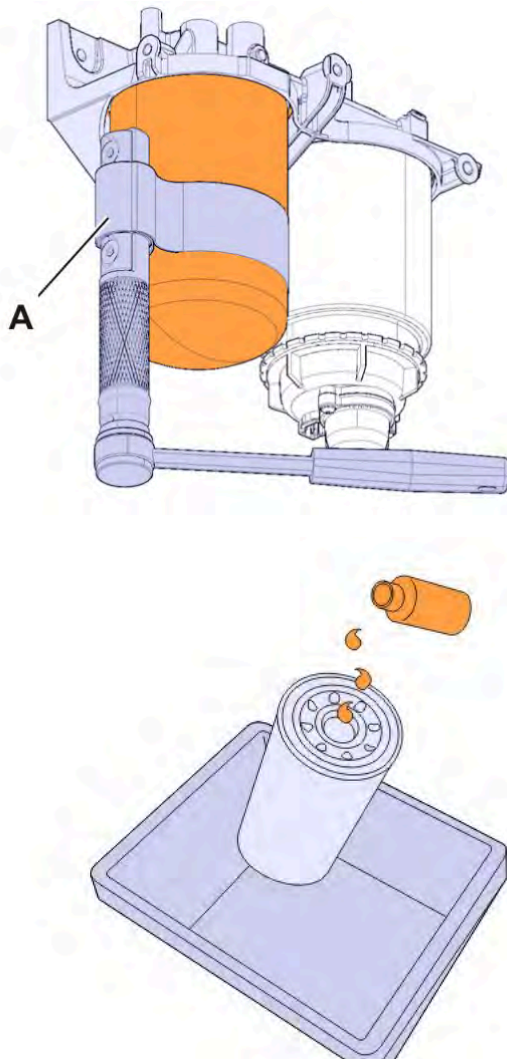

3. Use the hand primer to pressurize the system.
4. Check the fuel plug location shown in the pictures above and below for evidence of fuel leakage.

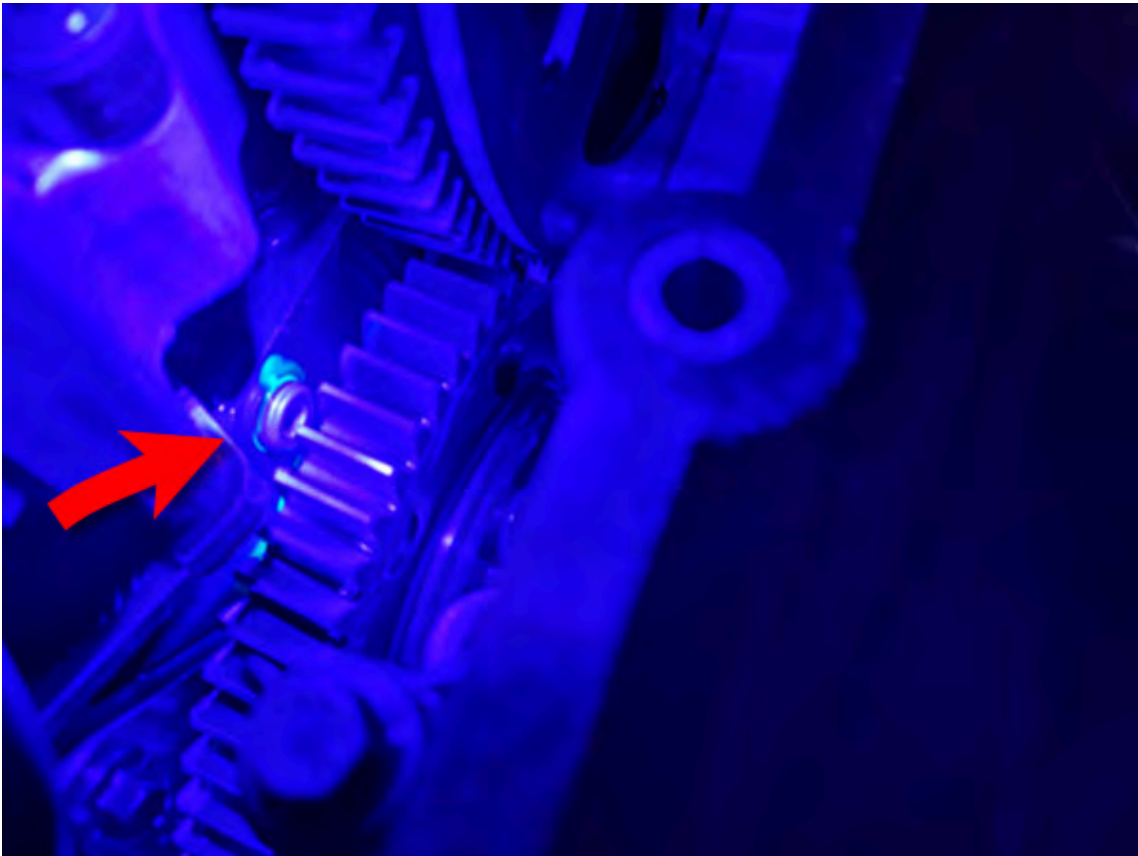

Repair

1. Ensure engine is on TDC (Cam and Crank) before major disassembly.
2. Drain fuel galley.
3. Follow Impact ID/Operation [2154-03-02-01 Camshaft, Replacement](#) and STOP at step 84.
 - DO NOT REMOVE the camshaft or camshaft bearing caps.
4. With the rocker shaft, upper timing cover, and cam gear removed, remove the fasteners for the adjustable idler gear and slide the gear toward the rear of the truck.
 - NOTE: Timing gear plate fasteners will not allow for complete removal of adjustable idler gear.
5. Remove the leaking fuel galley plug.
6. Verify the fuel galley plug threads in the cylinder head are clean and free from damage.
7. Install a **NEW UPDATED** fuel galley plug (**P/N 945065**) and gasket (**P/N 969011**). Torque fuel galley plug to 40 Nm +/- 3 Nm.

8. Using the hand primer, prime fuel system and verify there are no fuel leaks around the newly installed plug.

9. Slide the adjustable idler back into original position and loosely install the 5 fasteners.

- NOTE: Use new fasteners.

10. Reassemble using Impact ID/Operation [2154-03-02-01 Camshaft, Replacement](#) starting at step 102.

- NOTE: Gear train backlash WILL have to be adjusted, follow Impact ID/Operation [2154-05-03-02](#).

11. If not done already, change engine oil and filters.

12. Start the engine and verify proper operation and no leaks are observed.

13. Release the unit.

Related links and attachments

No links or attachments available



Share

to others that might find it helpful



Feedback

[Give feedback](#)

to help improve the content of this article

21522-2 Camshaft, Replacement



Illustrations may differ slightly from the actual vehicle being serviced. However, key components addressed in this information are represented as accurately as possible.



All threaded fasteners that do not have a tightening torque specification in the information are tightened to a standard torque. Standard torques are available in the following specification. ► [Standard Tightening Torques](#)



WARNING

Risk of serious personal injury.

Using the wrong technique when rotating the crankshaft can cause serious personal injury.

- Use the recommended engine barring techniques for manually rotating the crankshaft. Do not rotate the engine by pulling or prying the fan.



CAUTION

Risk of material damage.

Risk of impurities being introduced into the fuel system.

- Ensure conditions of maximum cleanliness when carrying out any work on the fuel system.



CAUTION

Risk of skin injury.

High fuel pressure.

- The injection system may be pressurised. When working on the injection system, remove the first part cautiously



CAUTION

Risk of material damage.

The engine may be hot.

- Make the adjustment on a cold engine.



CAUTION

Service Information Advisory.

If you are not properly trained and certified in this procedure, ask your supervisor for training before you perform it.

- You must read and understand the precautions and guidelines in Service Information, Function Group 2, "General Safety Practices, Engine" before performing this procedure.



CAUTION

Risk of material damage.

Applying more sealant than a specified volume will lead to oil leakage. Excess sealant can result in over-compression and damage to the gasket.

- ▶ The surface must be thoroughly cleaned and free of oil, dirt or grease prior to applying the sealant.
- ▶ Oil or grease on the surface will prevent proper bonding of parts.

 **CAUTION**

Risk of material damage.
 The turbocharger can be damaged if foreign particles enter the charge air system. Particles as small as 1 mm can cause damage.

- ▶ Observe maximum cleanliness when working on the charge air system. Cover or plug openings immediately.

Special tools

J-42189	88800232	88800420	88840317	9992669
9996400	9998264	9999683	9999696	85109051
85109250	J-44514B			

- 1 Park the vehicle on a level surface.
- 2 Apply the parking brake.
- 3 Place the gear lever in neutral.
- 4 Install the wheel chocks.

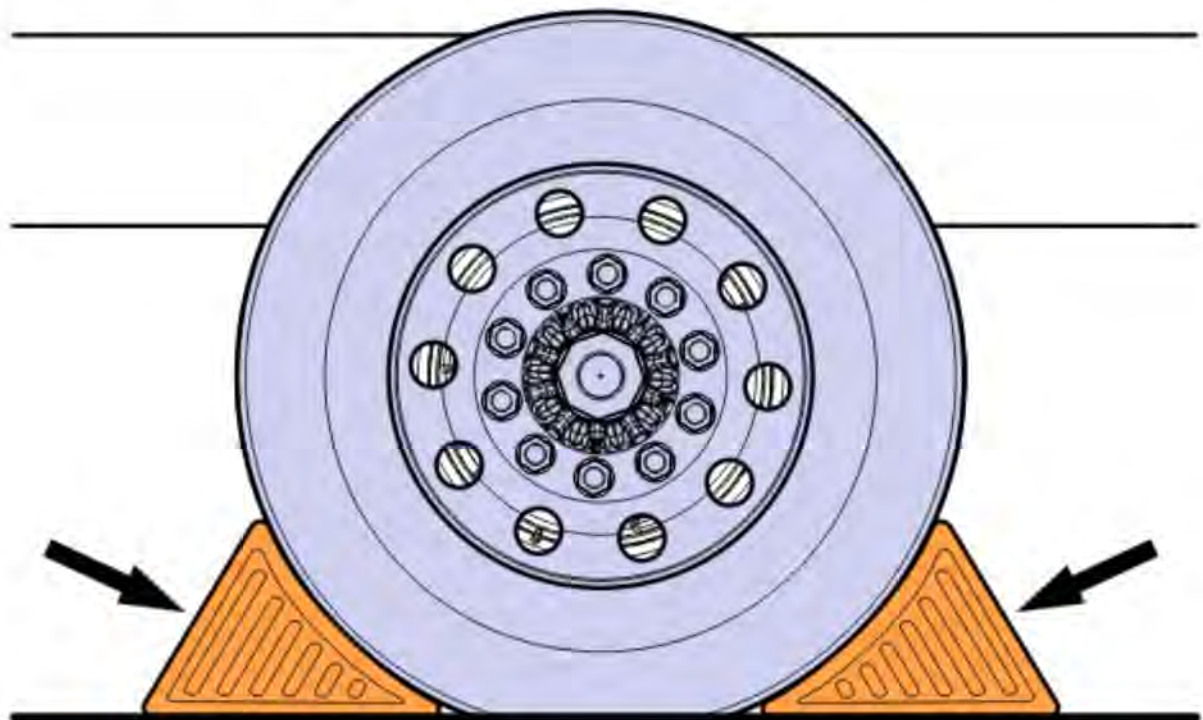

- 5 Disconnect the cable from the negative terminal.

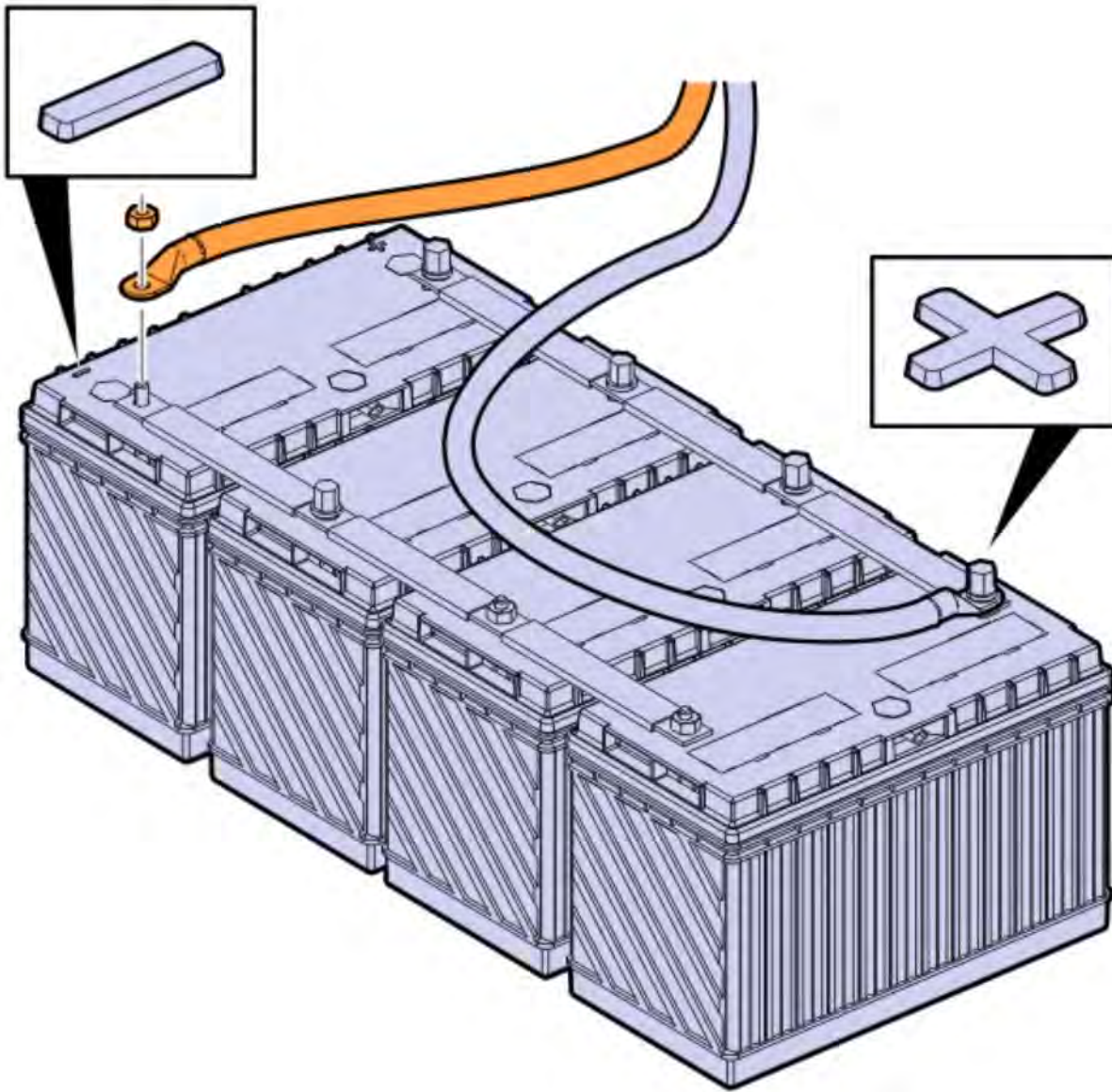

6	<p>Perform this procedure when the condition below is met.</p> <p>Conditions</p> <ul style="list-style-type: none"> • If the vehicle is equipped with a removable bumper end cap <p>▶ Remove the end cap.</p>
7	<p>Unlatch and raise the hood.</p>
8	<p>Drain the compressed air tanks.</p>

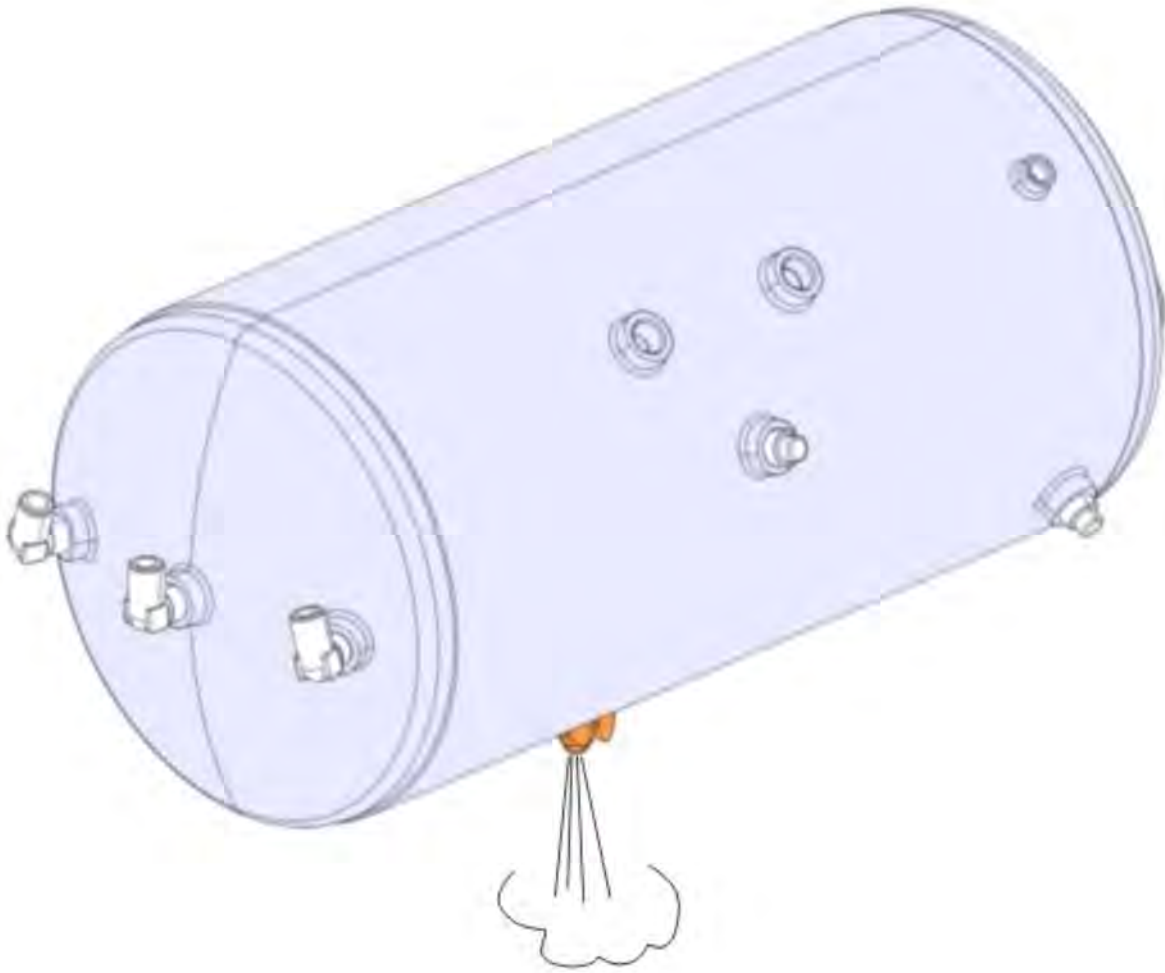

9	Loosen the clamps.
---	--------------------

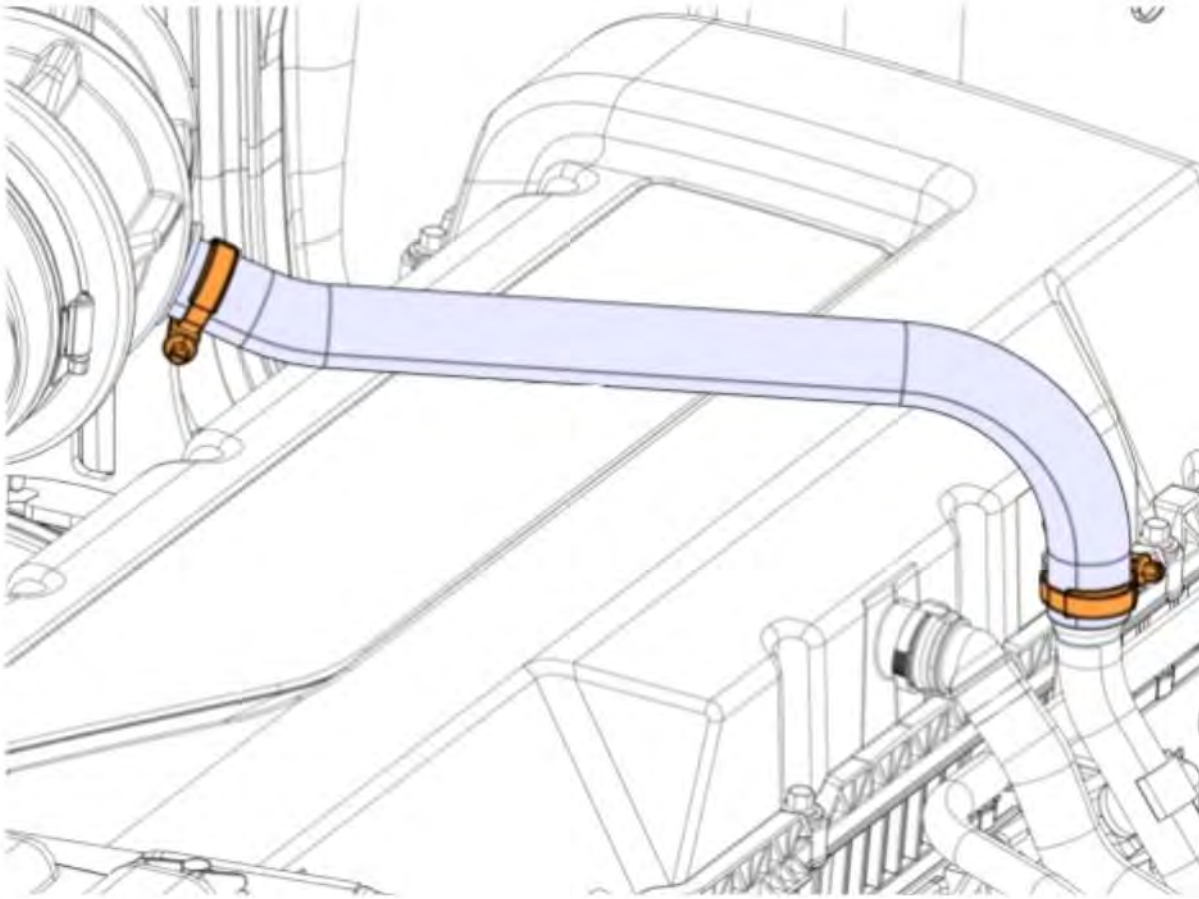

10 Remove the hose.

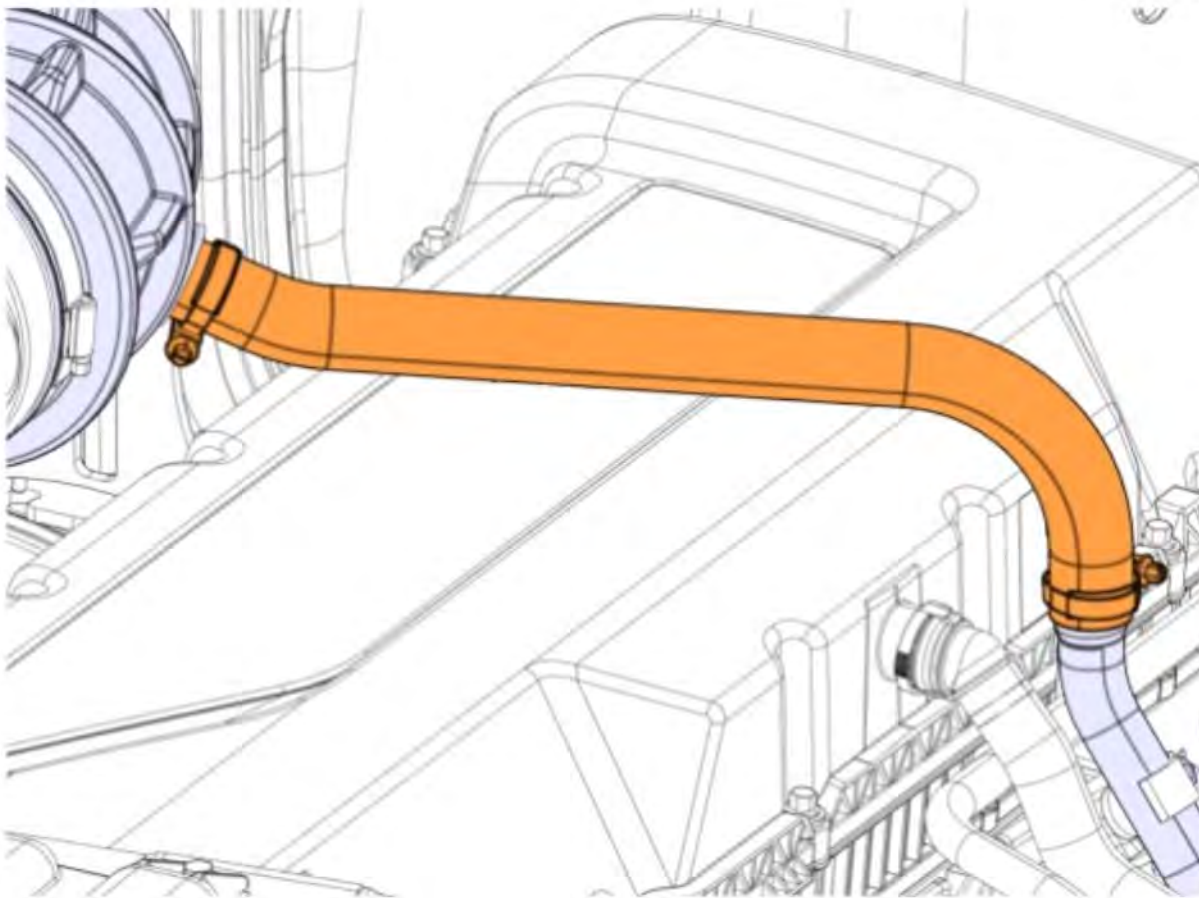

11 Remove the cable ties.

12 Disconnect the sensor connector.

**Note**

To avoid damaging the sensor, do not remove from the pipe.

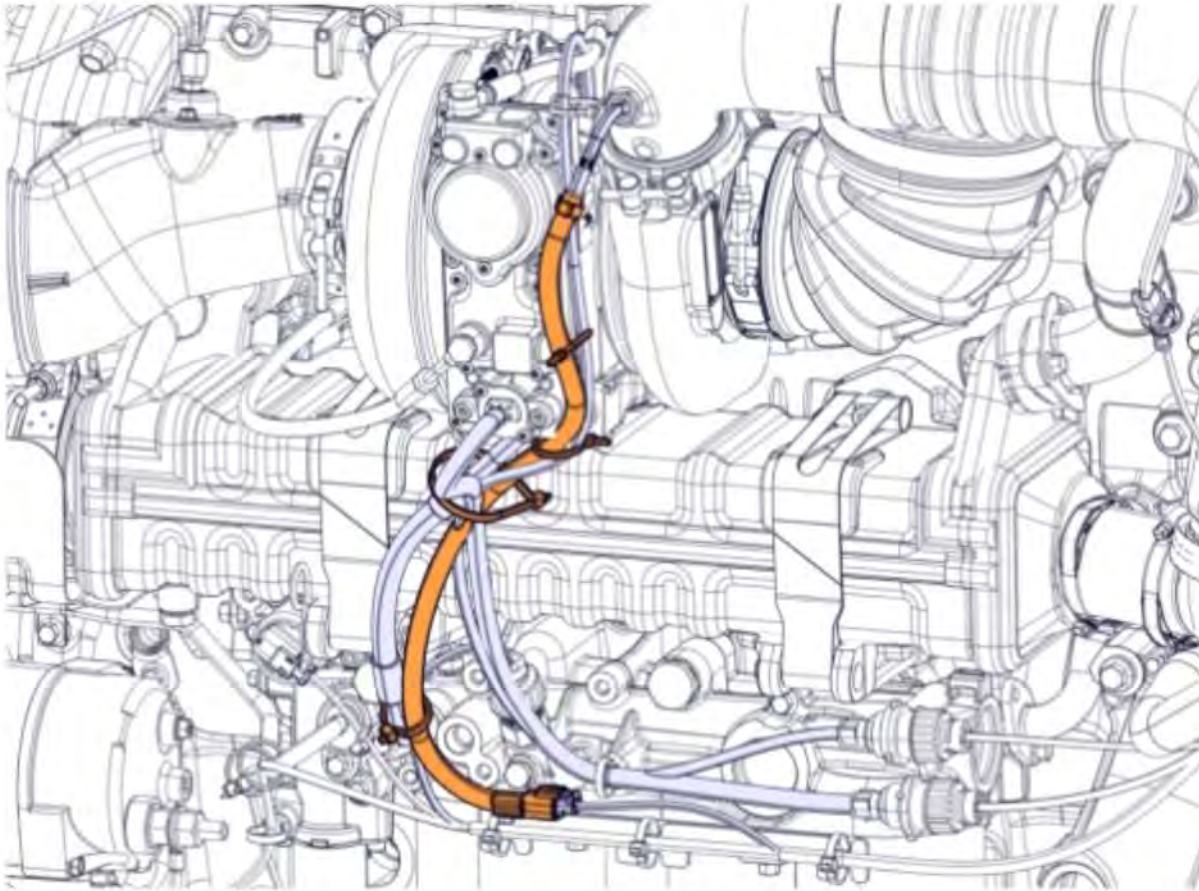

13 Loosen the clamps.

14 Remove the pipe assembly.

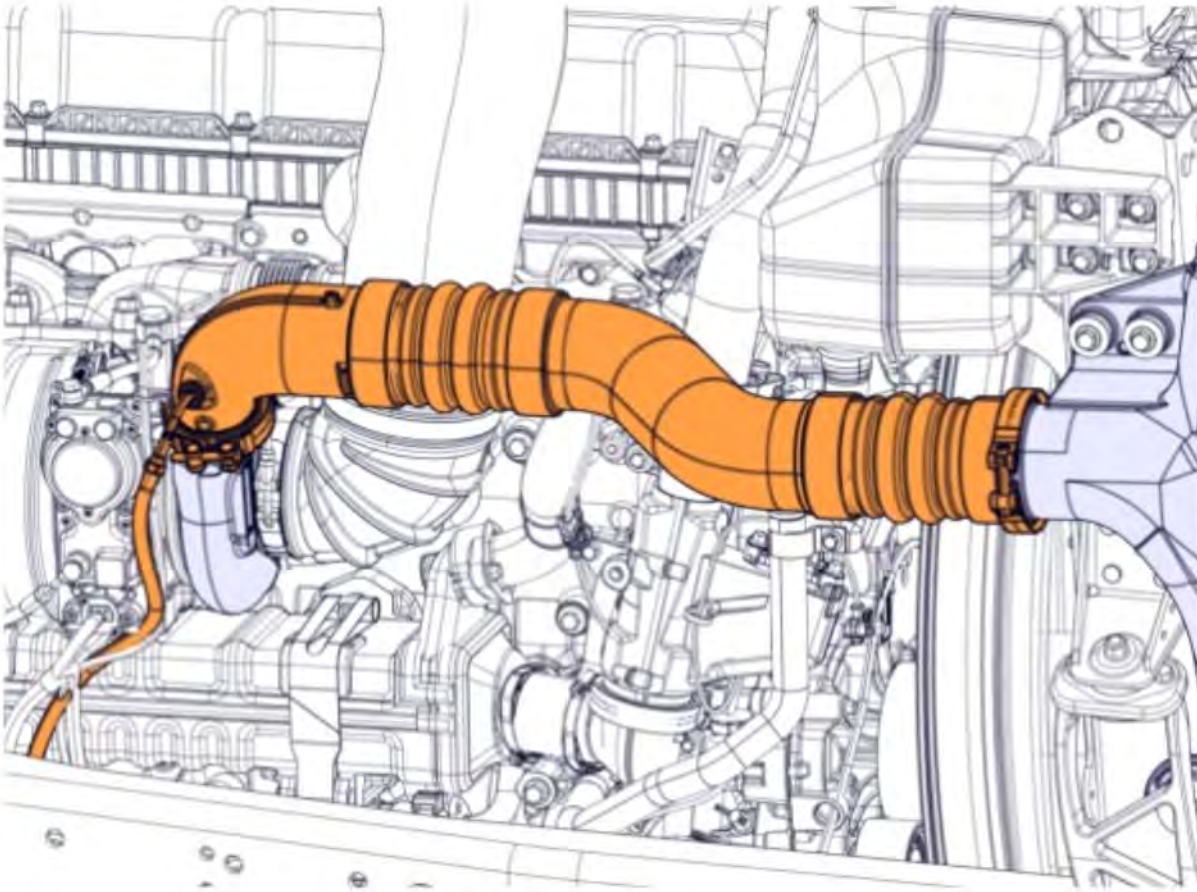

15 Loosen the clamps.

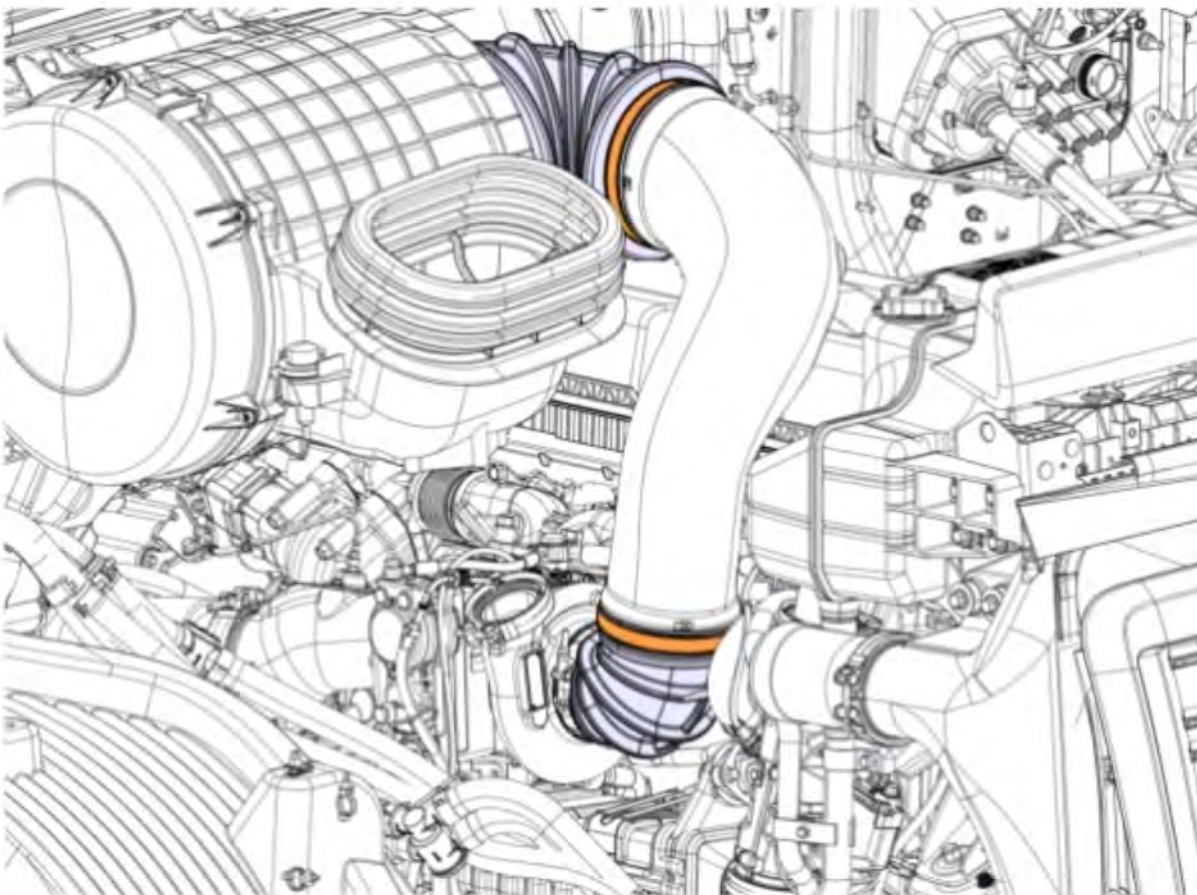

16 Remove the air duct.

Copyright to this documentation belongs to the Volvo Group. No reproduction, copying, change, amendment or other similar disposal is entitled without prior written consent by the Volvo Group

The information contained herein is current at the time of its original distribution, but is subject to change. The reader is advised that printed copies are uncontrolled.

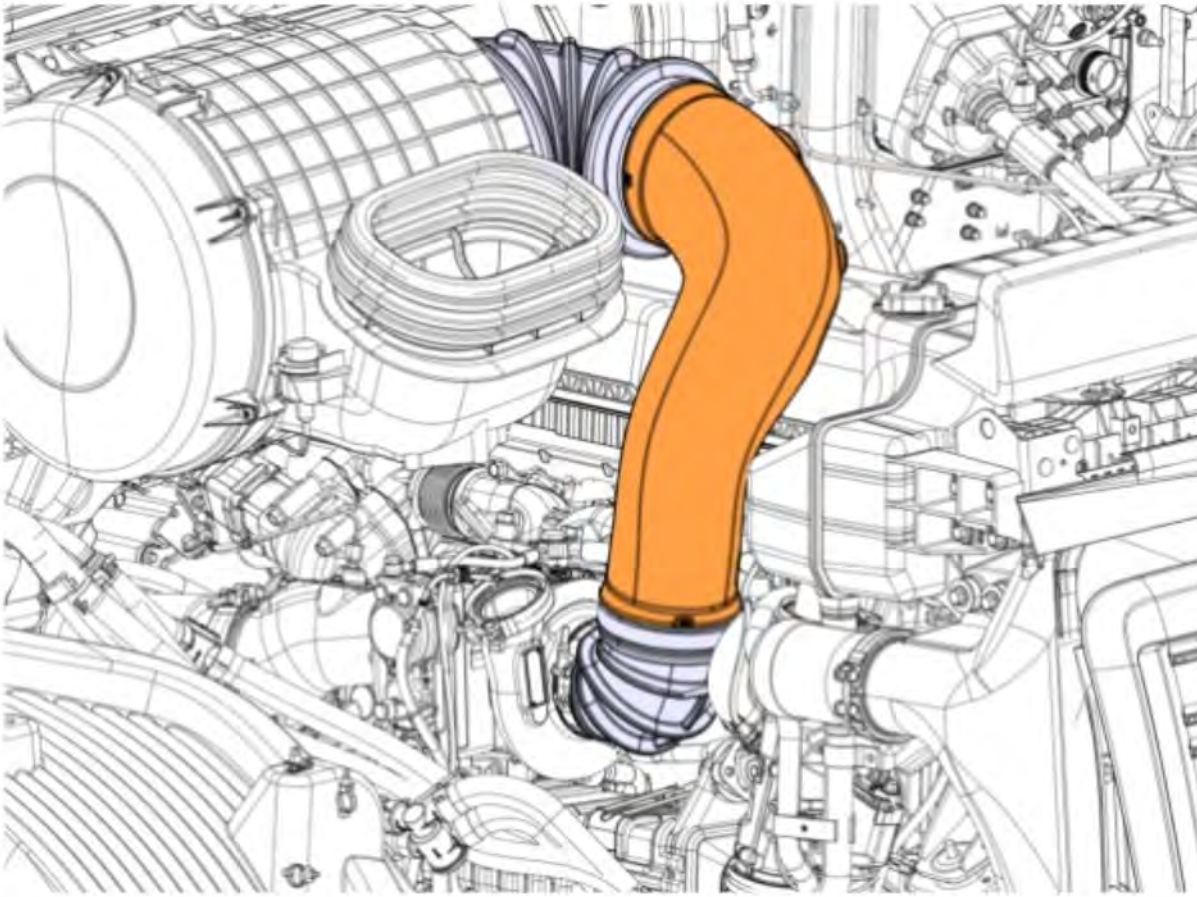

17 Remove the screws.

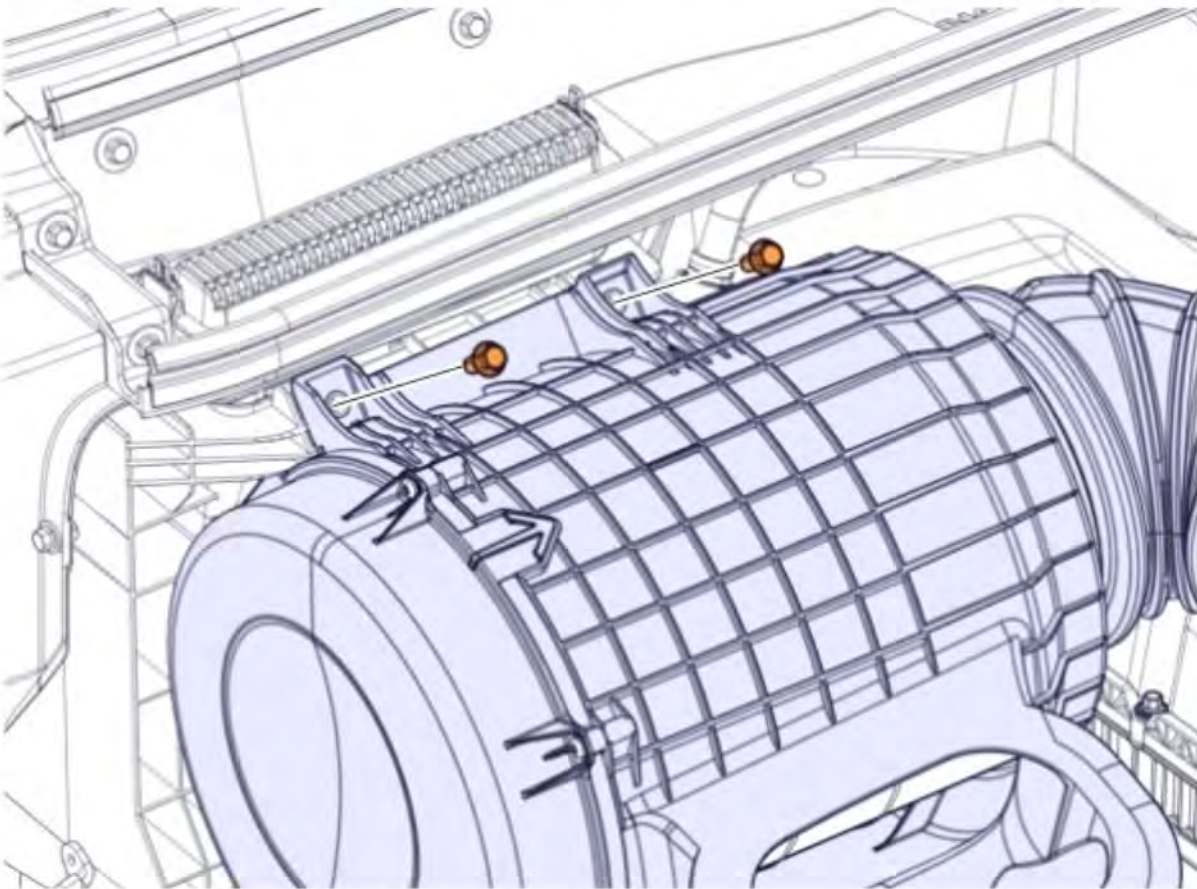

18 Remove the air filter housing.

Copyright to this documentation belongs to the Volvo Group. No reproduction, copying, change, amendment or other similar disposal is entitled without prior written consent by the Volvo Group

The information contained herein is current at the time of its original distribution, but is subject to change. The reader is advised that printed copies are uncontrolled.

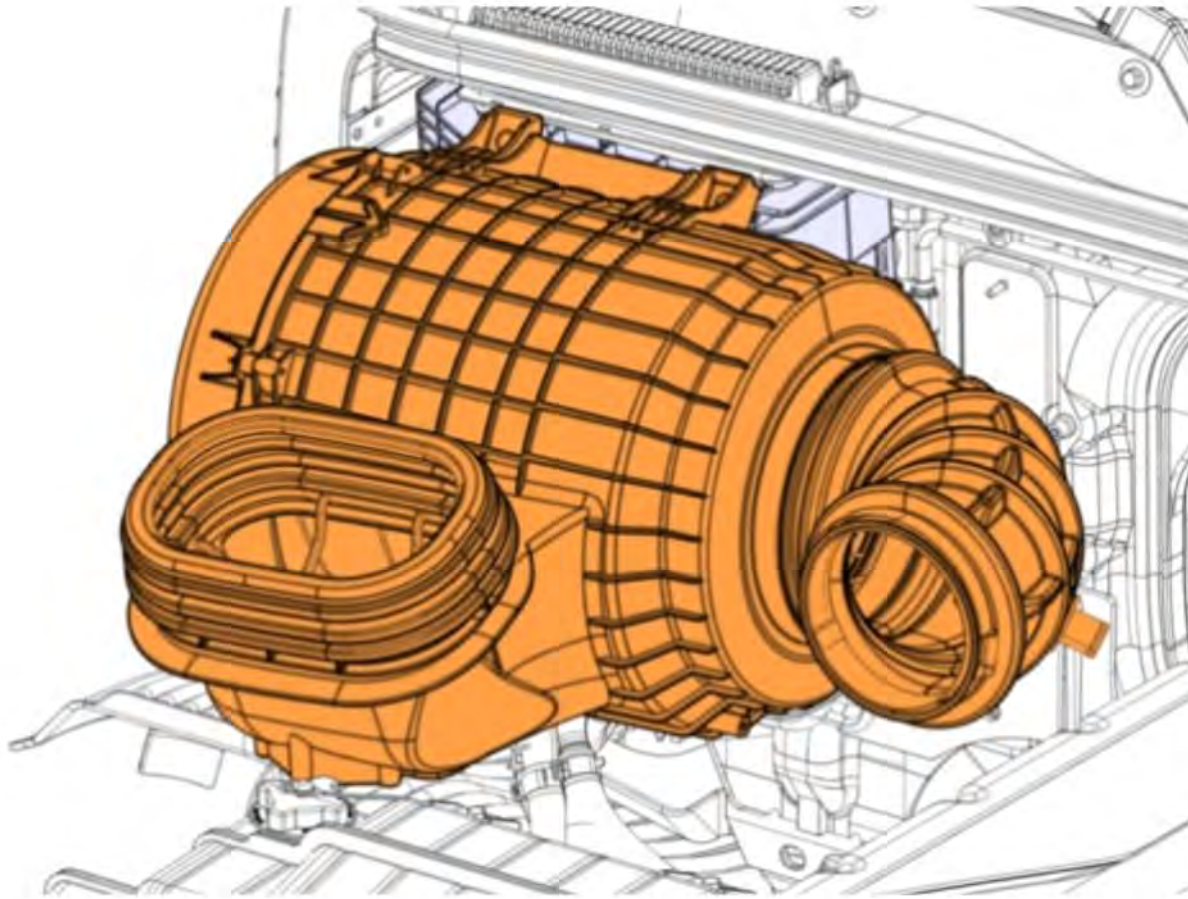

19	Disconnect the connector.
----	---------------------------

20	Remove the ties.
----	------------------

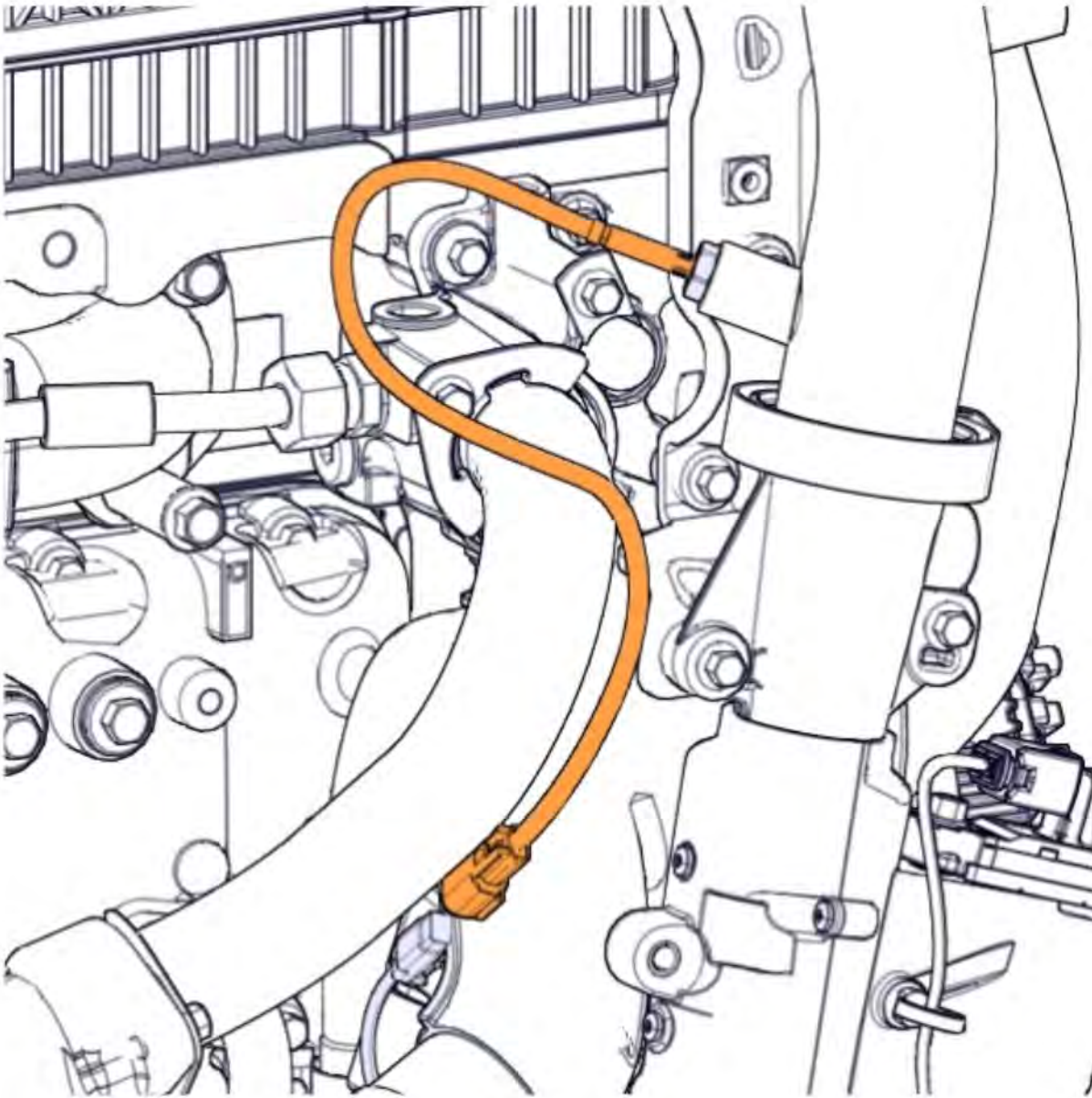

21	Remove the screws.
----	--------------------

22	Remove the clamp.
----	-------------------

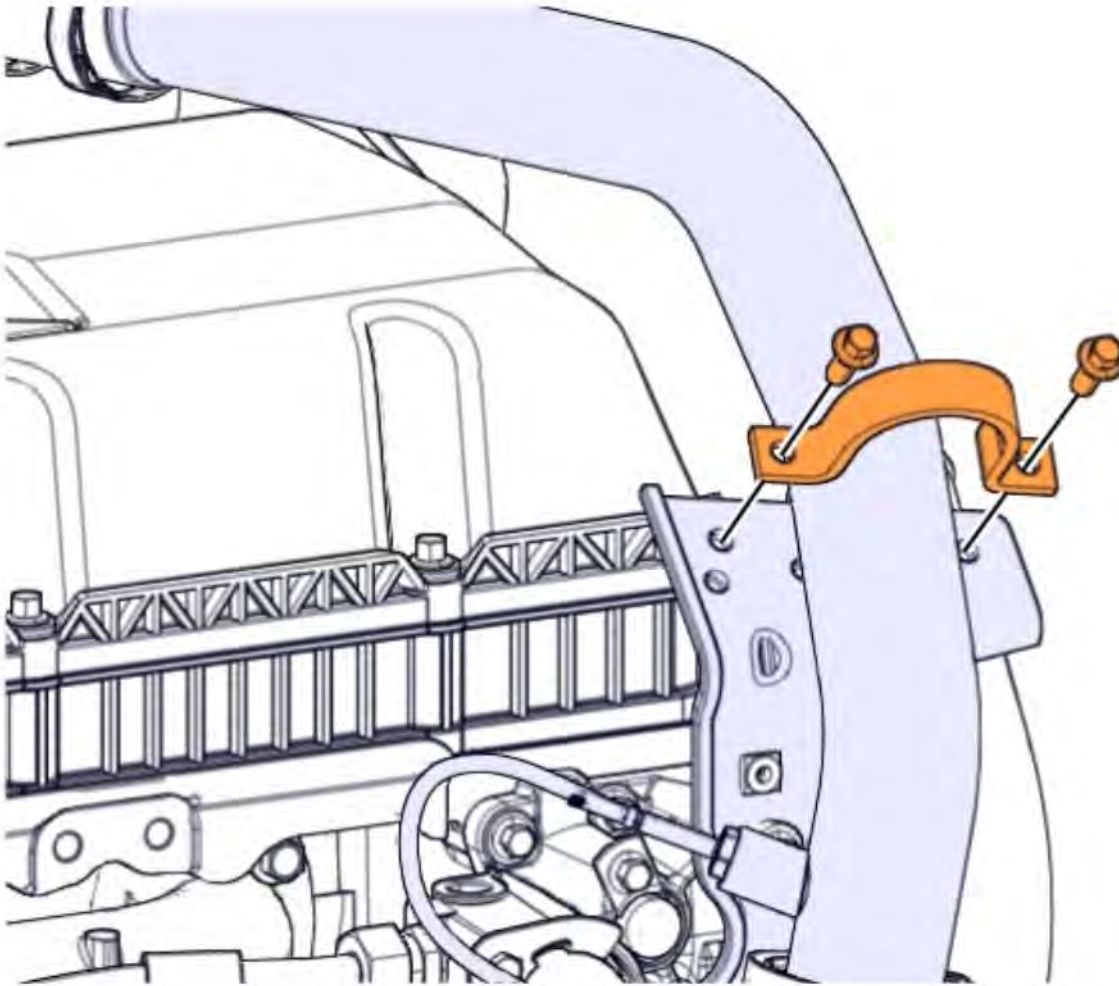

23	Loosen the clamps.
----	--------------------

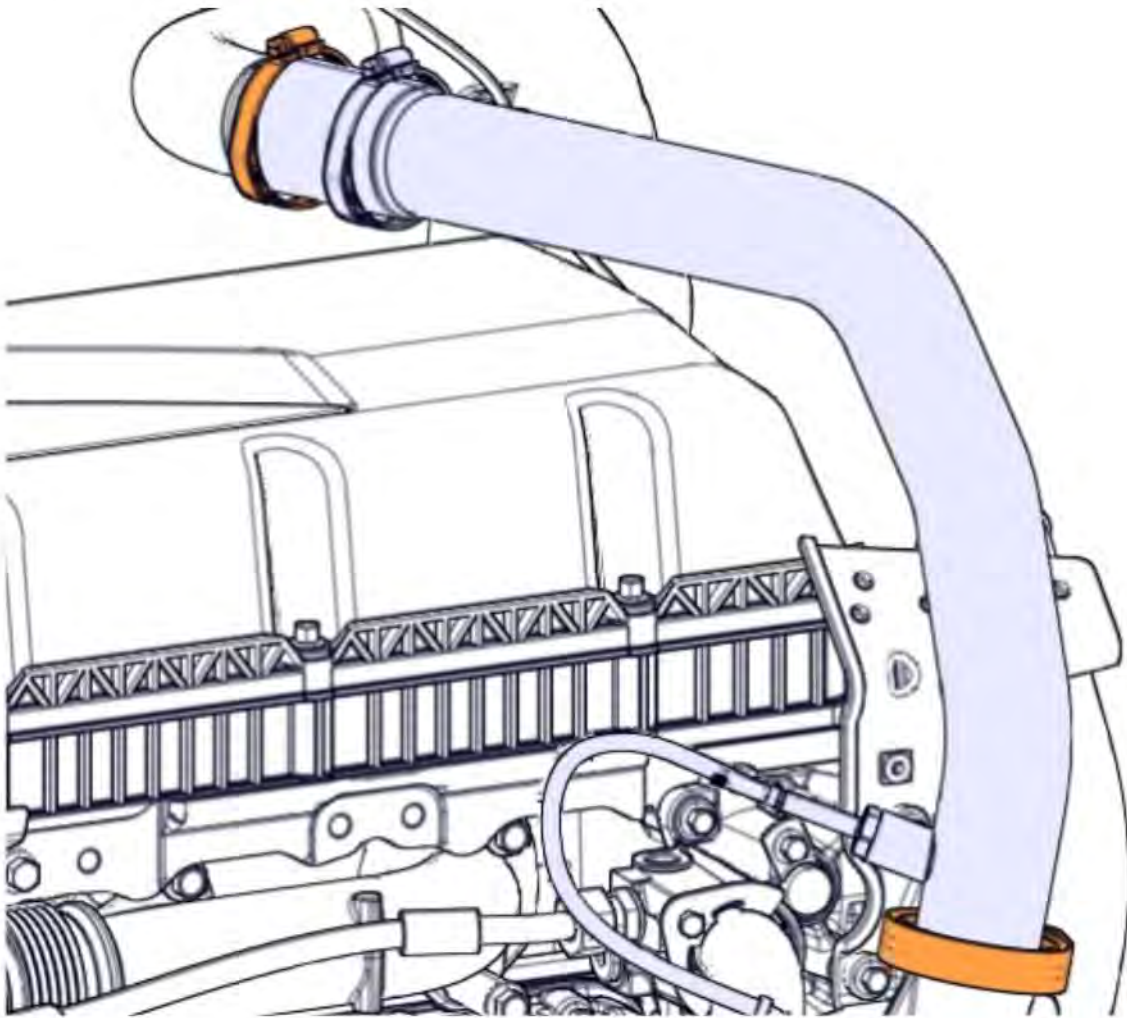

24	Remove the pipe.
----	------------------

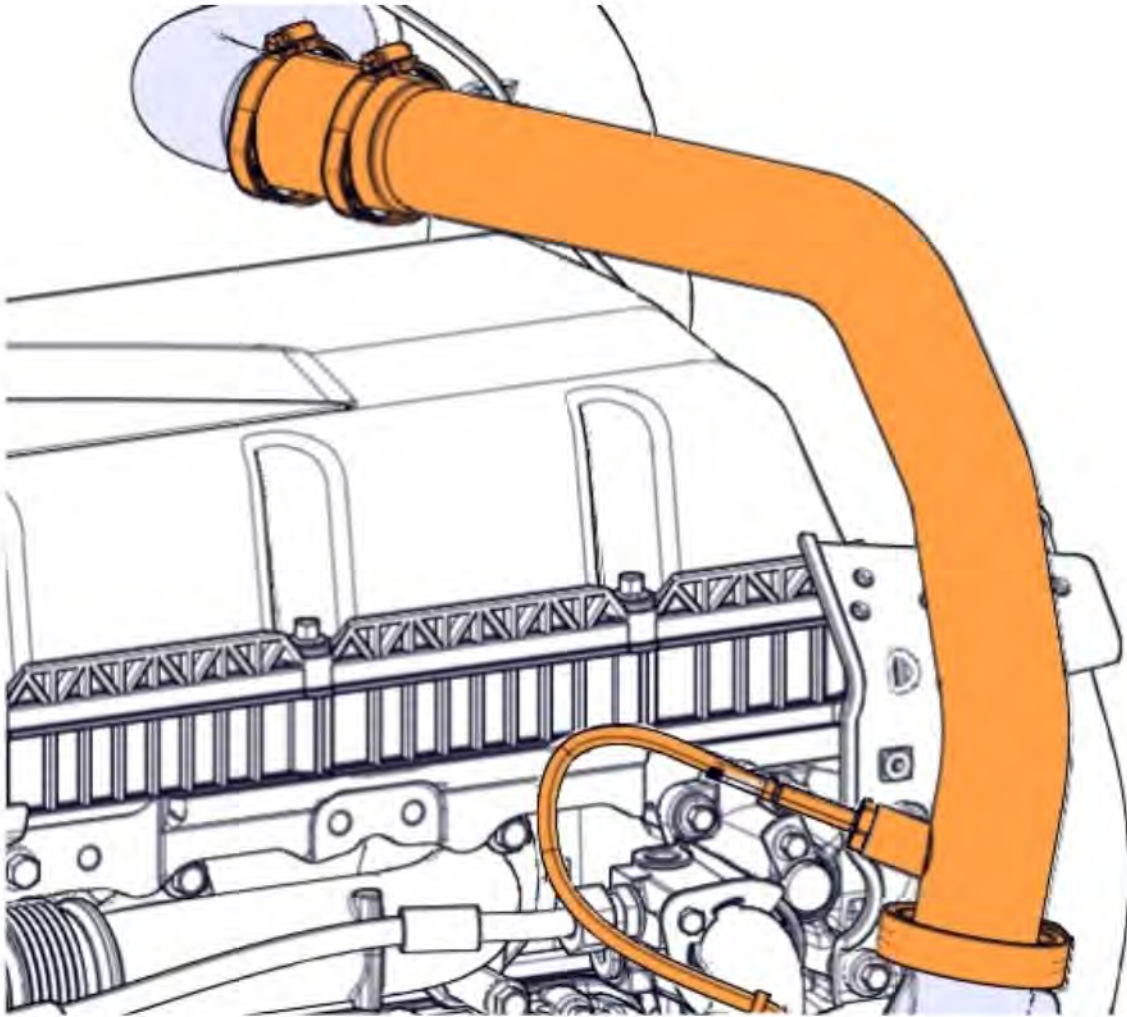

25	Remove the protecting covers.
26	Remove the screws.
27	Remove the panel.

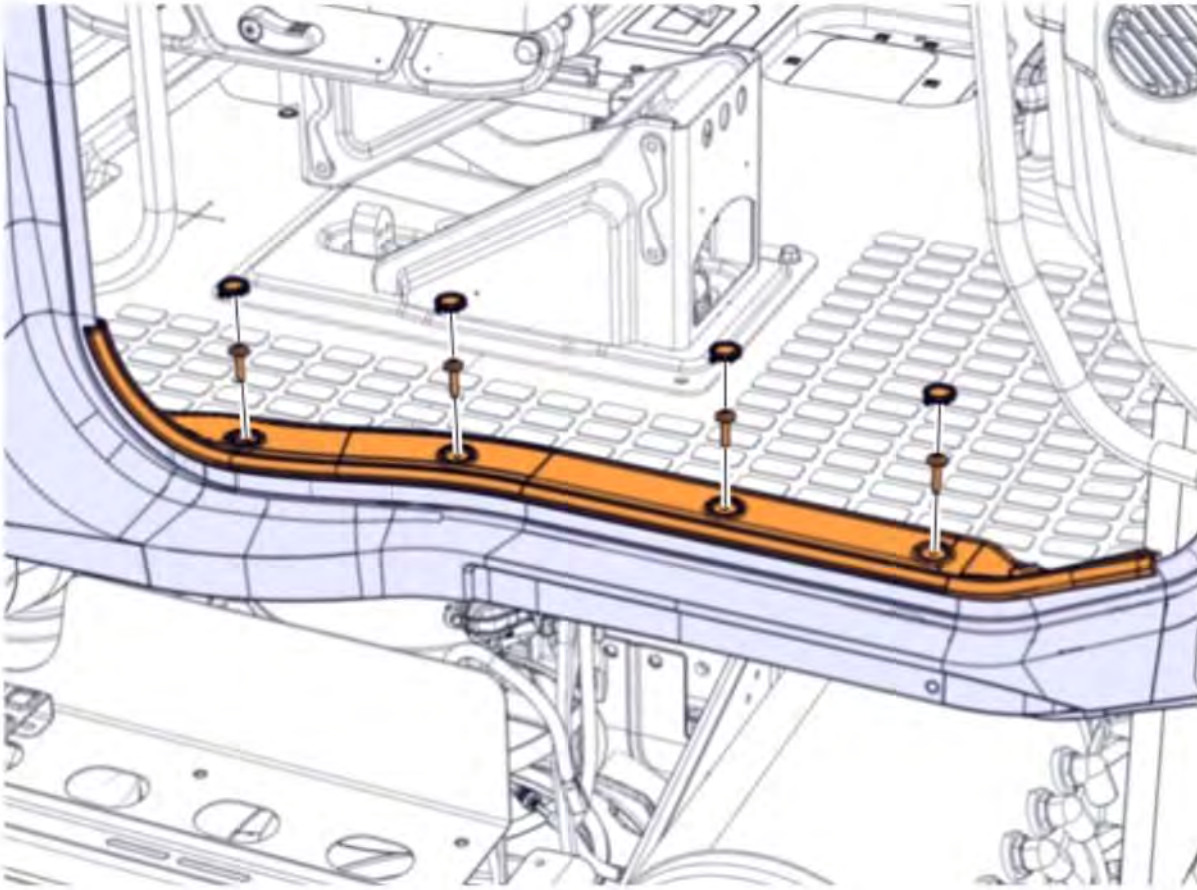

28	Remove the seat belt.
29	Disconnect the air tube.
	Required material
	DISASSEMBLY TOOL J-42189

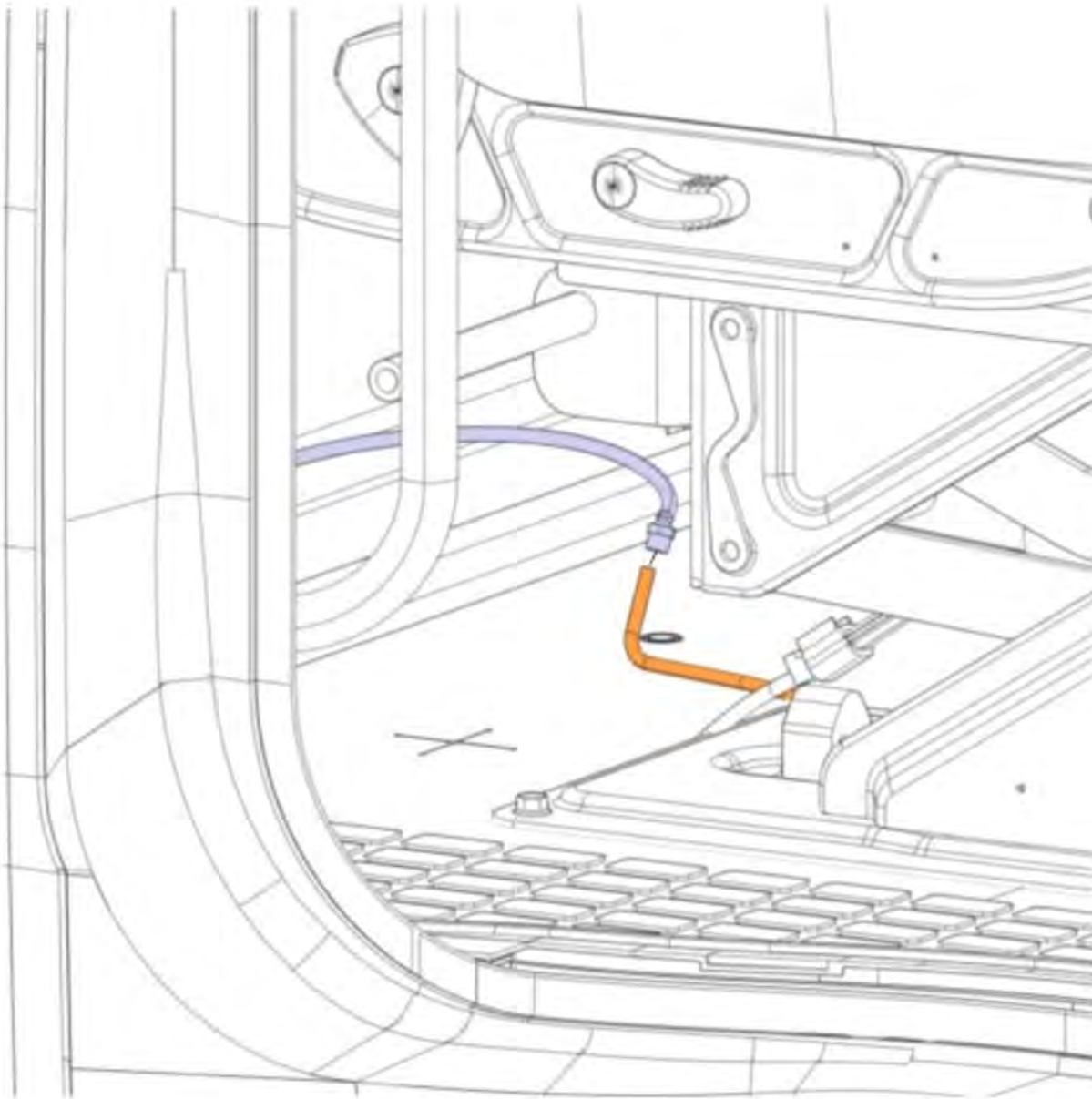

30	Disconnect the connector.
----	---------------------------

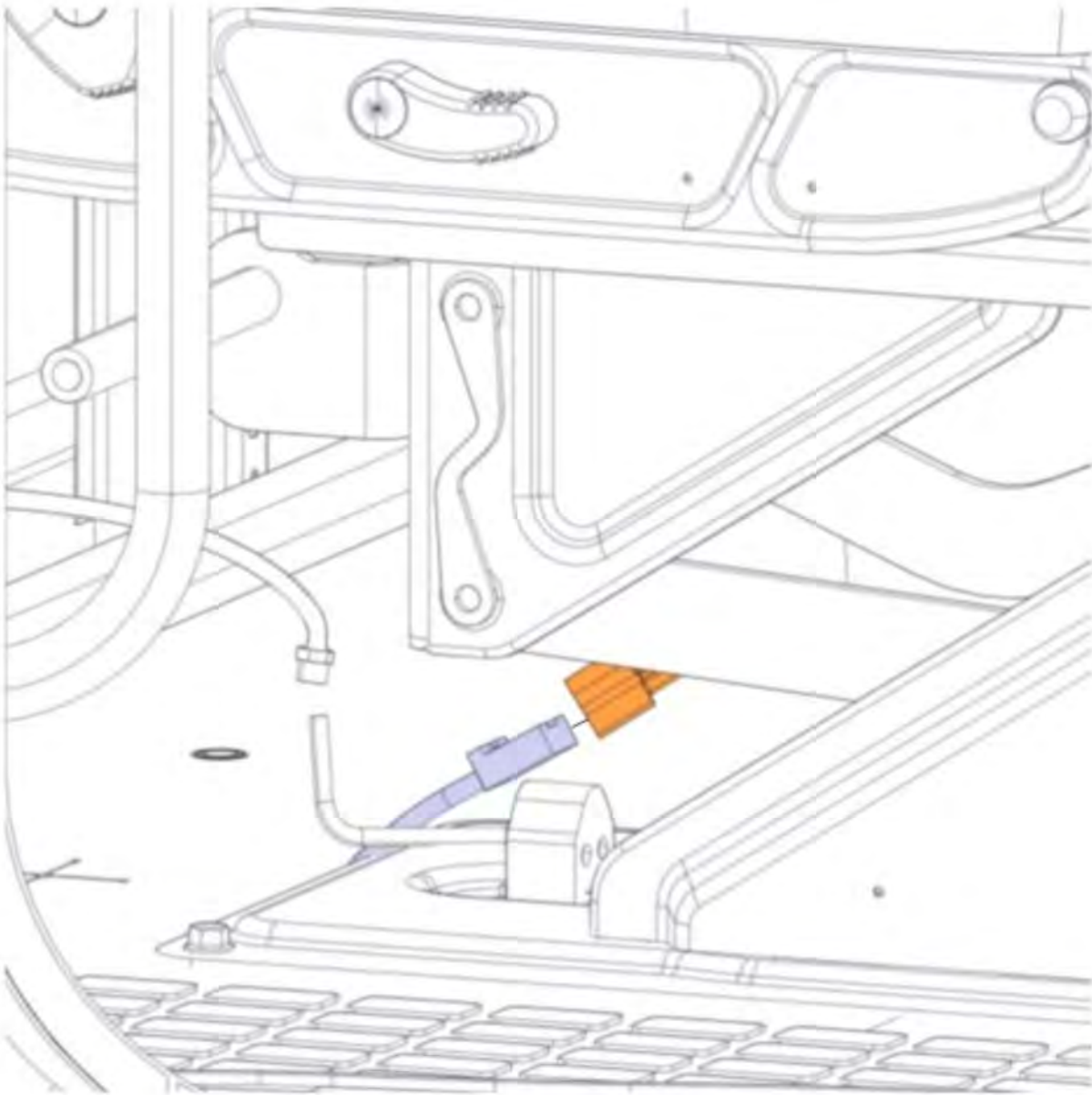

31	Remove the screws.
----	--------------------

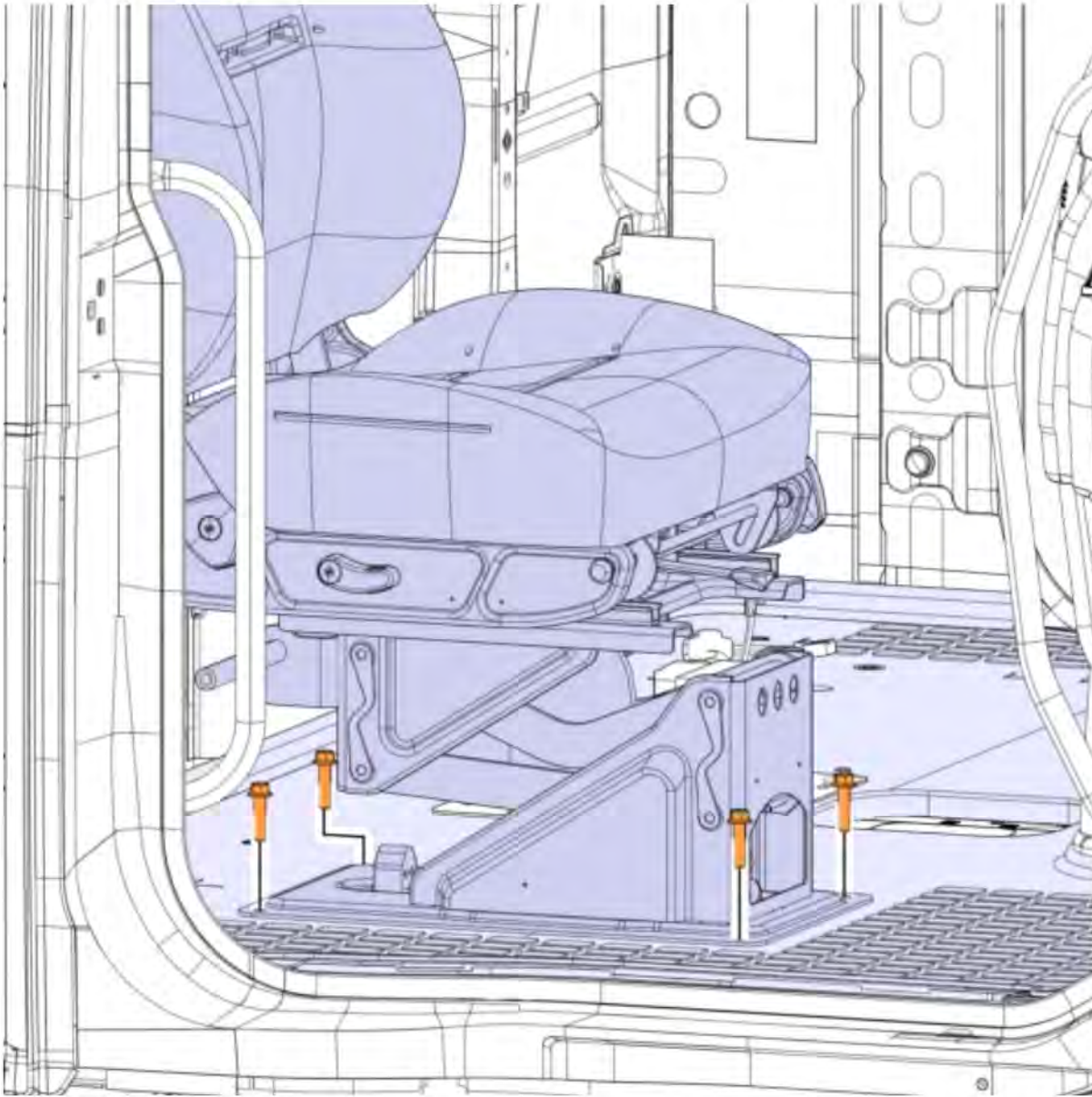

 WARNING	
<p>Risk of serious injury. Heavy component.</p>	
<p>▶ Exercise caution when moving the component. Assistance is required.</p>	
32	Remove the seat from the cab.

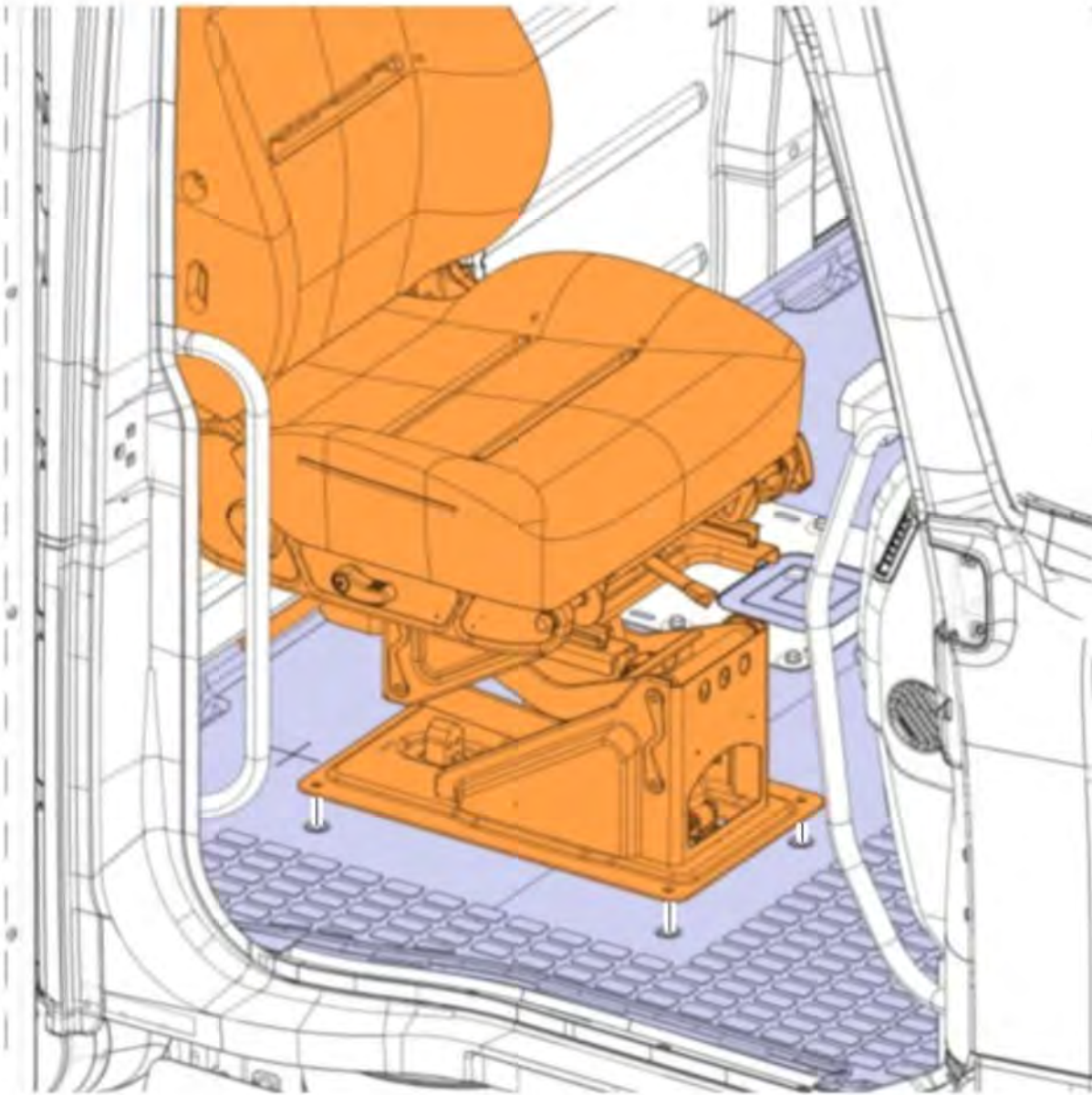

33	Remove the screw cover.
----	-------------------------

34	Remove the screws.
----	--------------------

35	Remove the handle.
----	--------------------

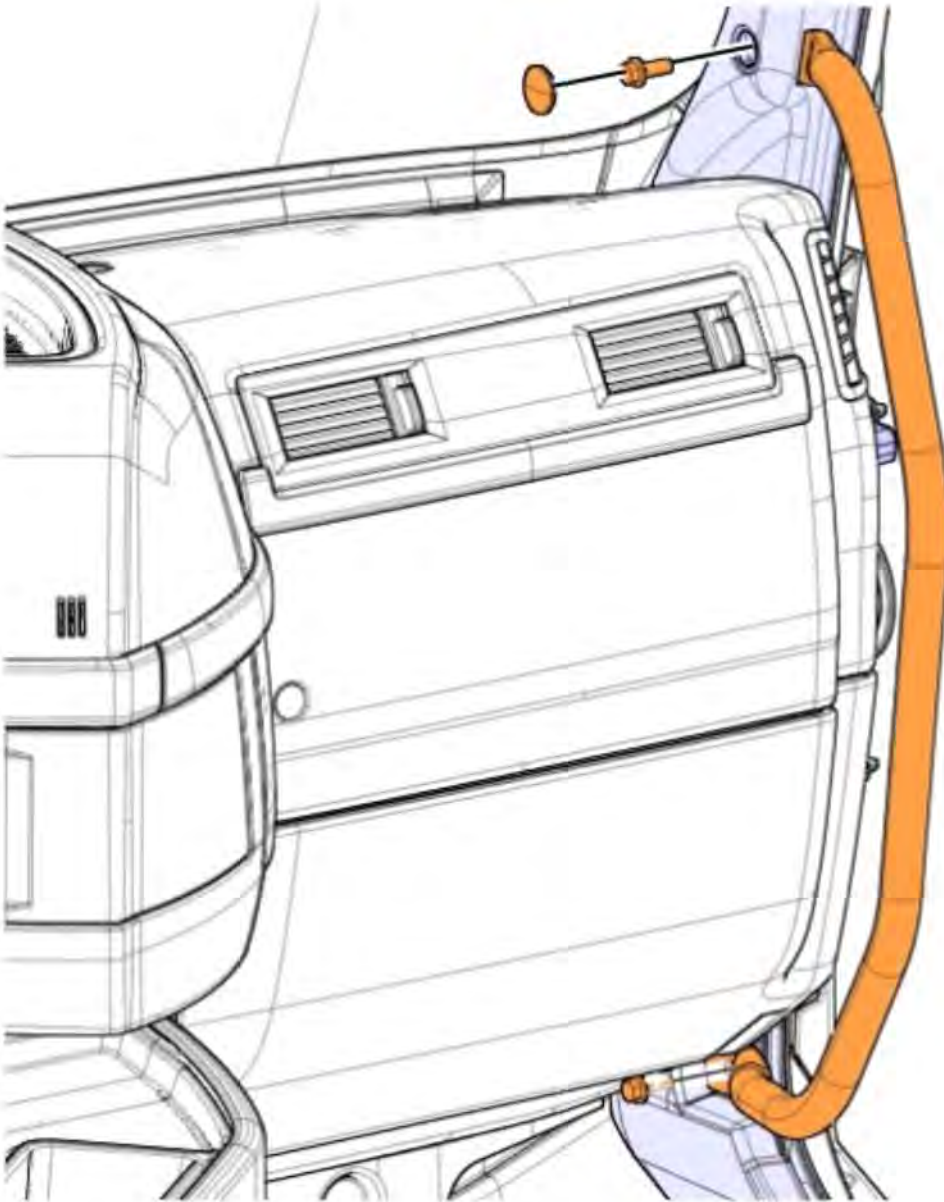

36	Remove the nut.
----	-----------------

37	Remove the panel.
----	-------------------

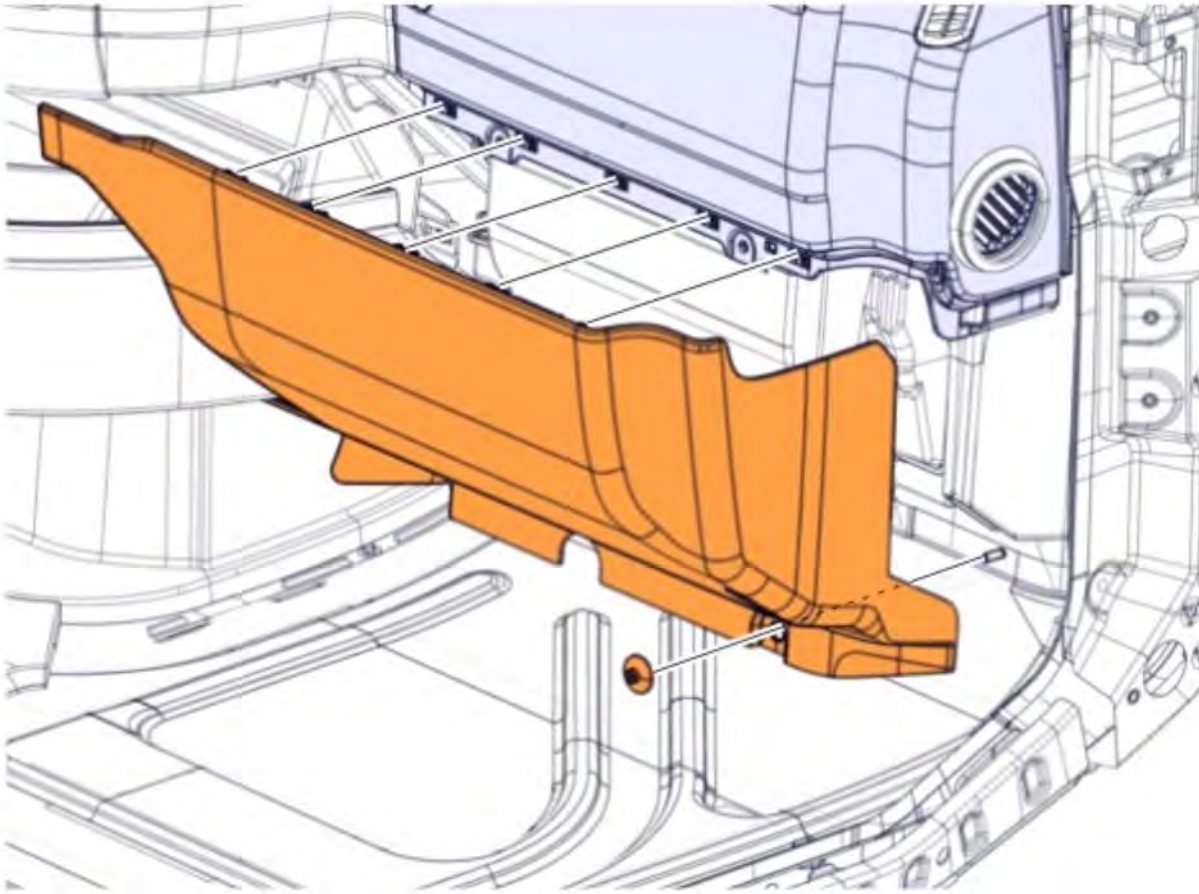

38 Remove the panel.

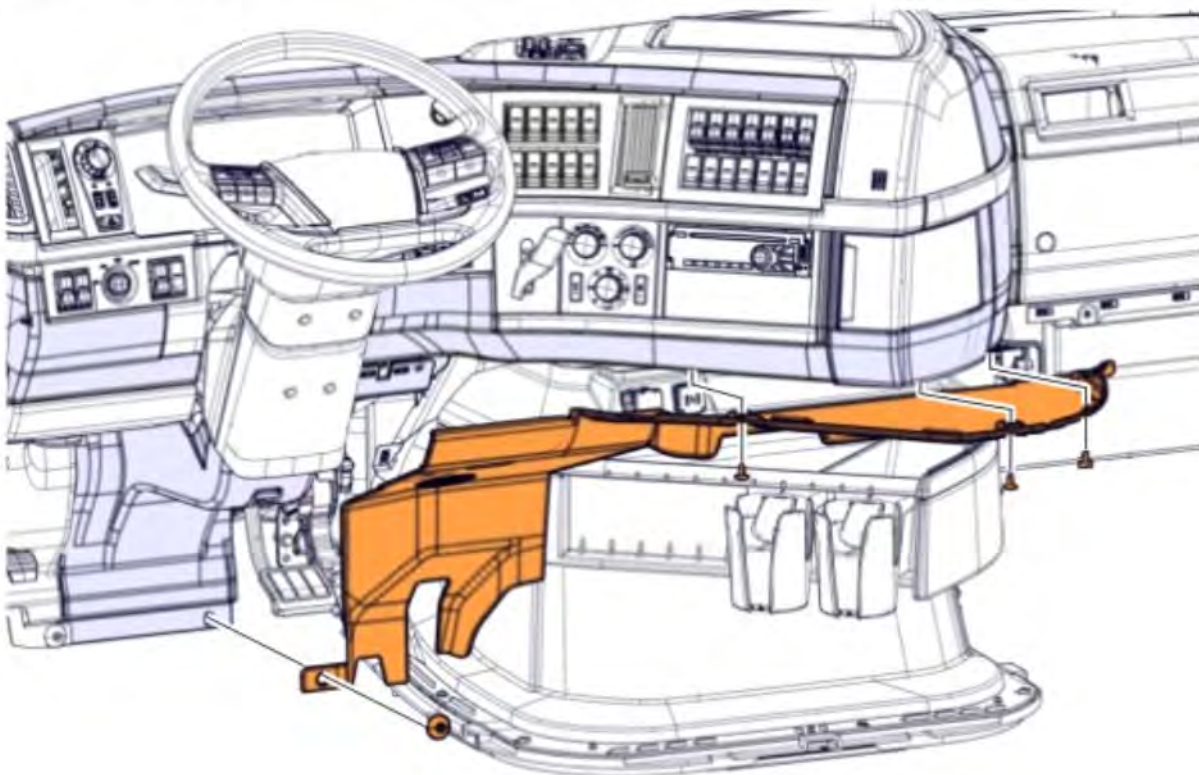

39 Move the floor cover to access the screws.

40 Remove the screws.

41 Remove the engine cover.

42 Disconnect the connector.

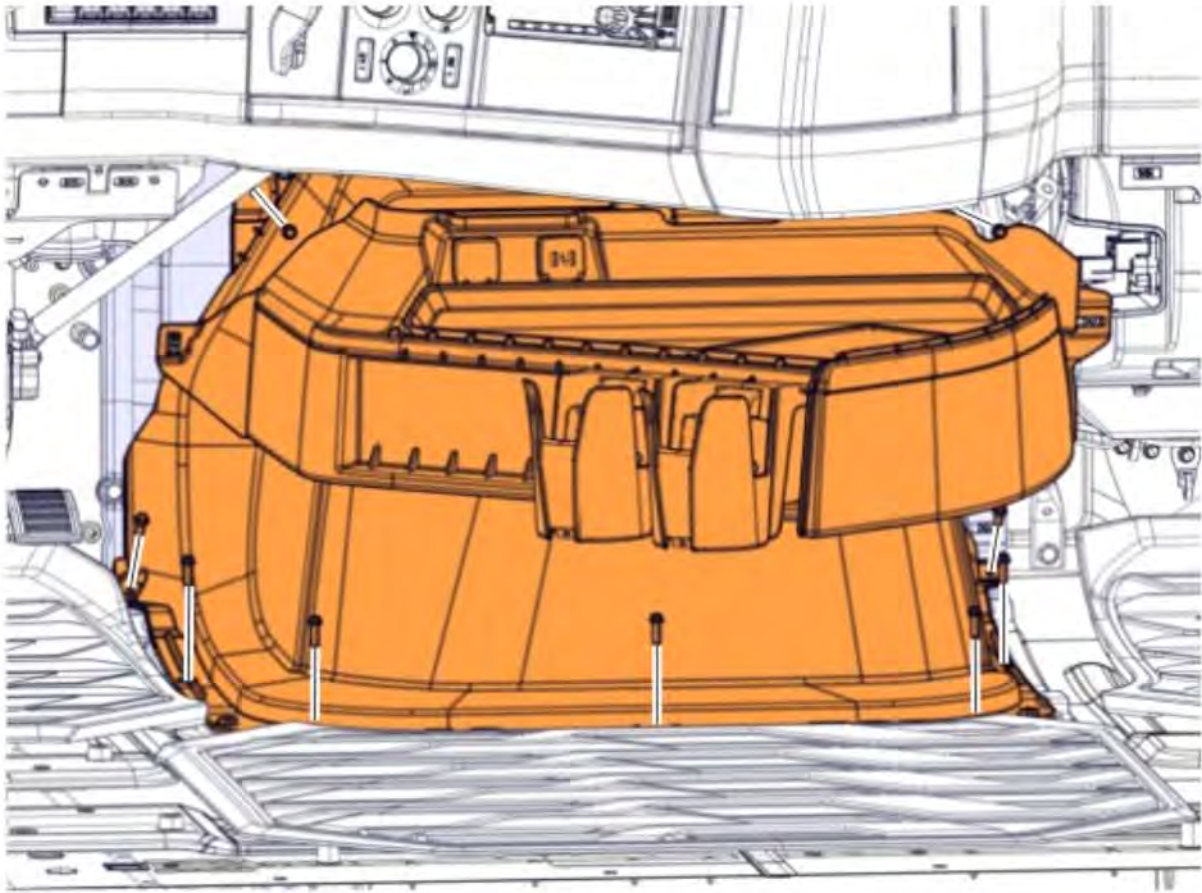

43 Remove the pipe.

i **Note**
If not previously removed.

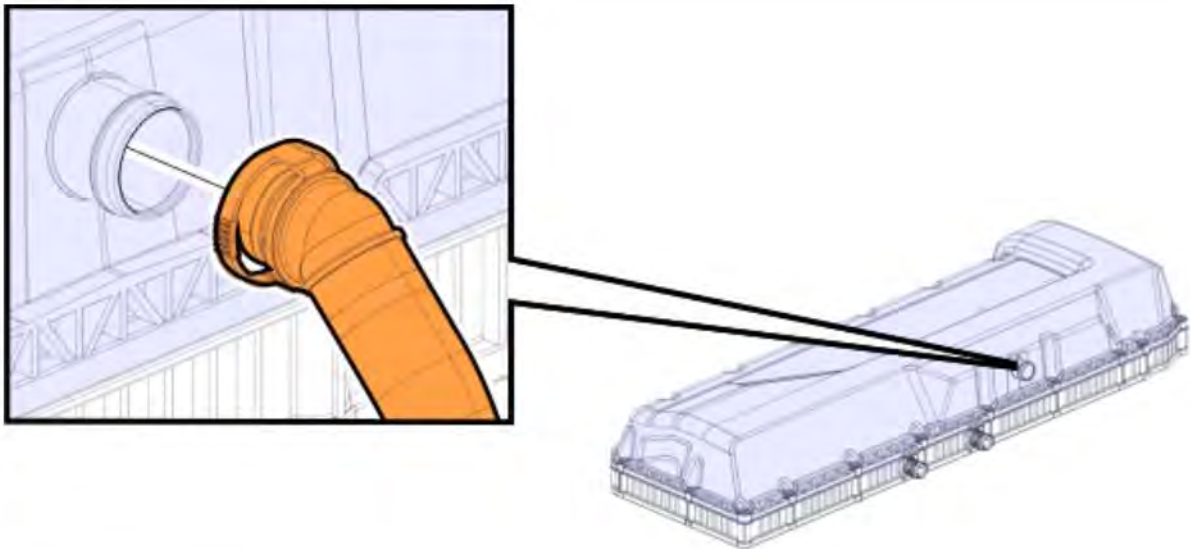

44 Loosen the screws.

45	Remove the valve cover.
	<p>Service hint</p> <p>It is possible, when removing a valve cover screw, that the crush sleeve is drawn out with it. Take care to prevent the sleeve from falling into the gear train as this could result in engine damage.</p>

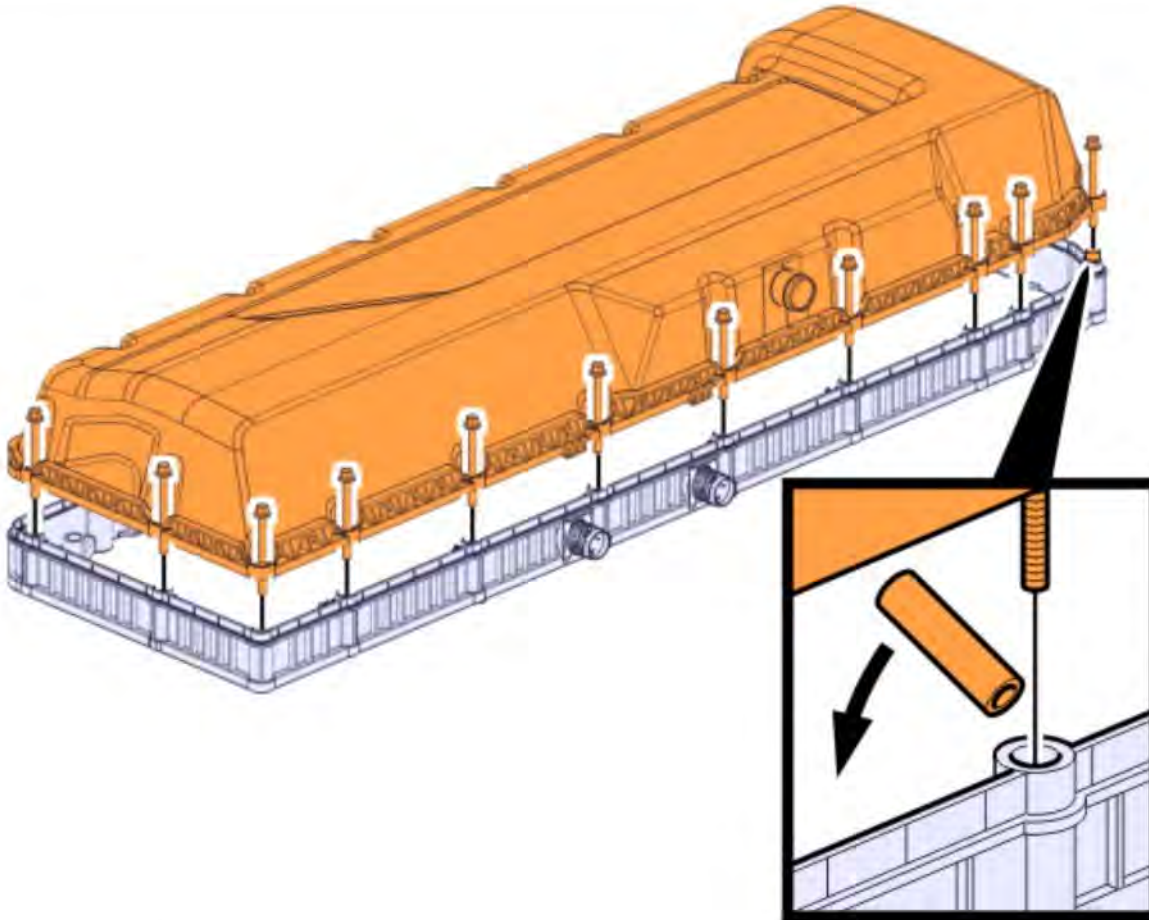

46	Disconnect the connectors.
47	Loosen the screws.
48	Remove the frame.

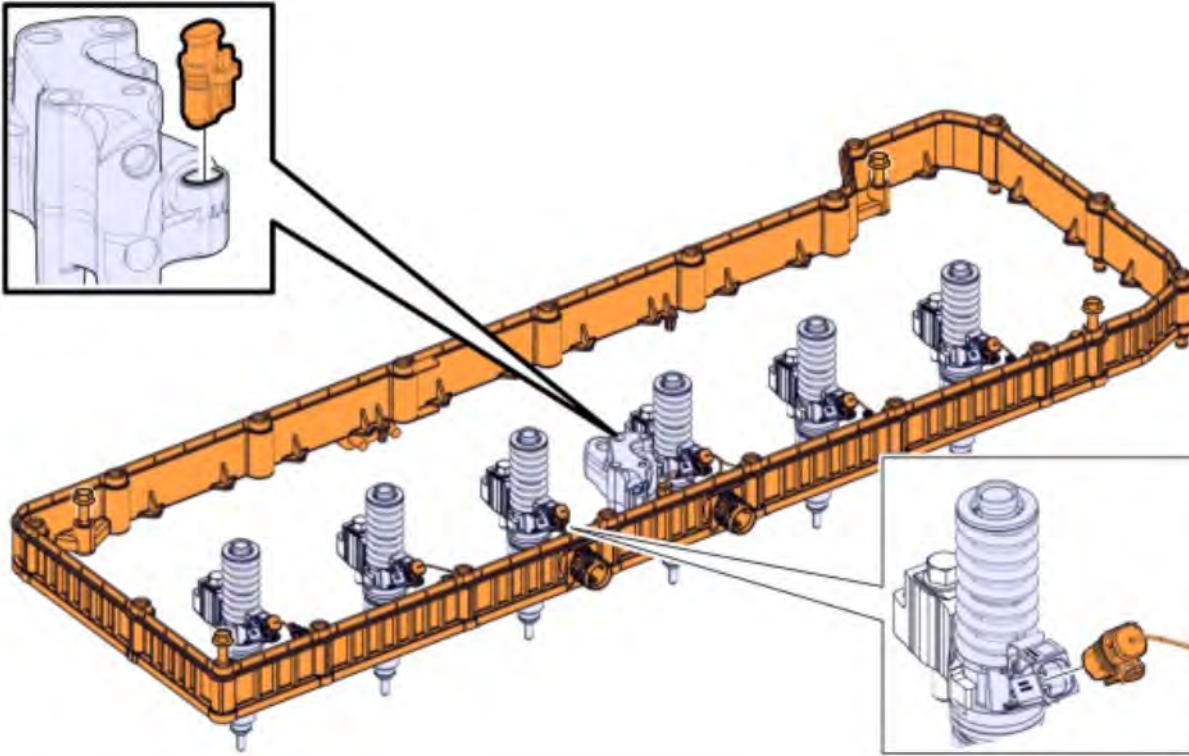

49 Remove the gasket.

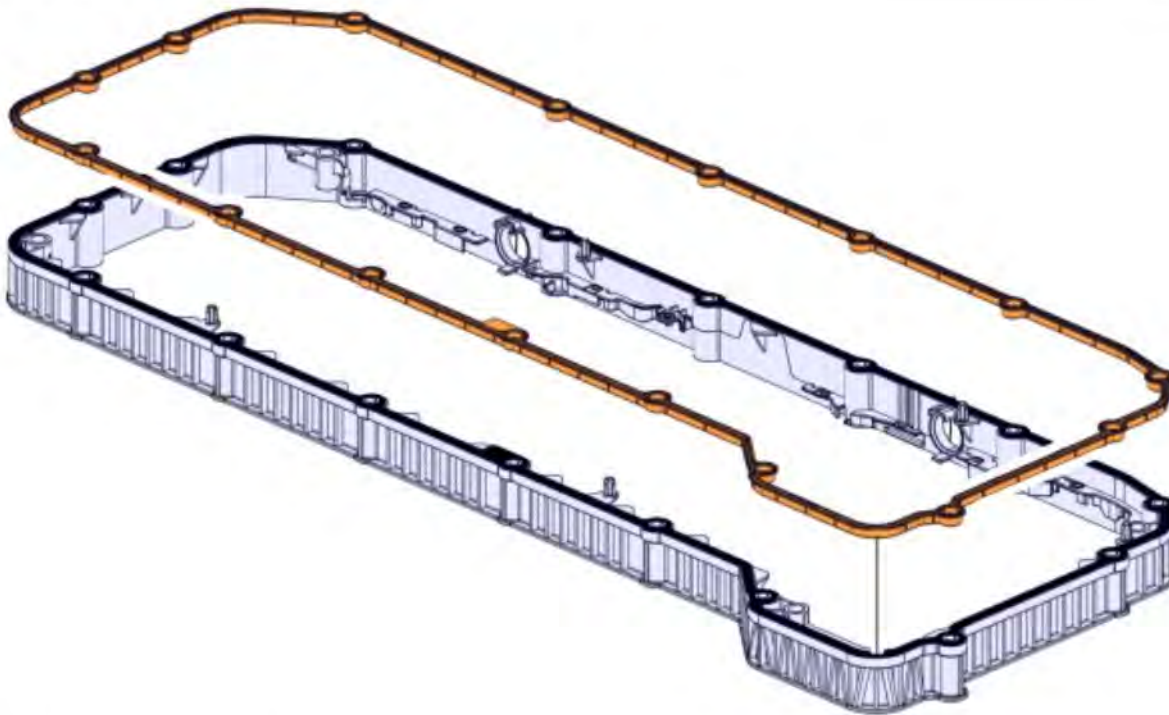

50 Remove the screws.

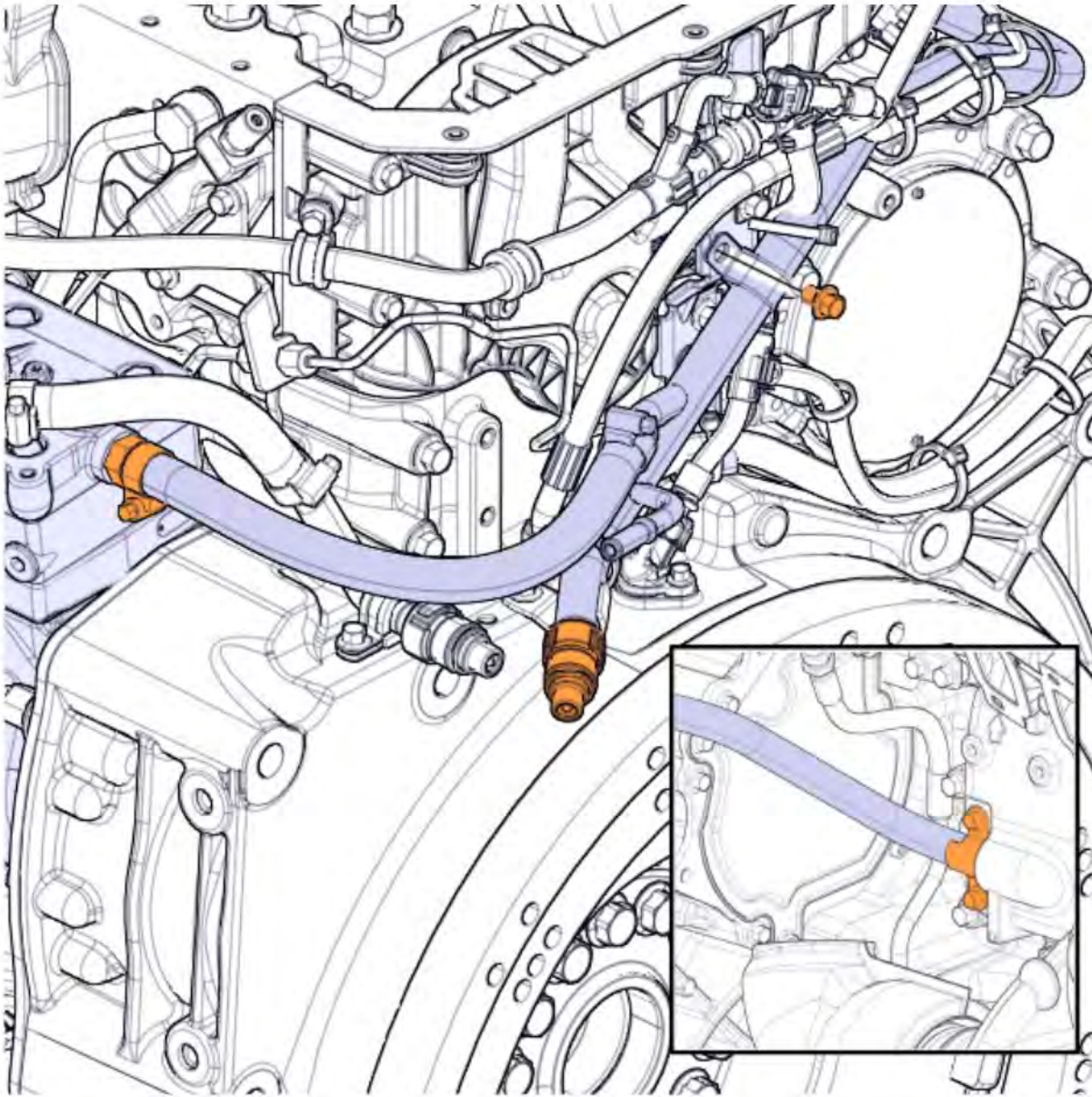

51	Remove the pipe.
----	------------------

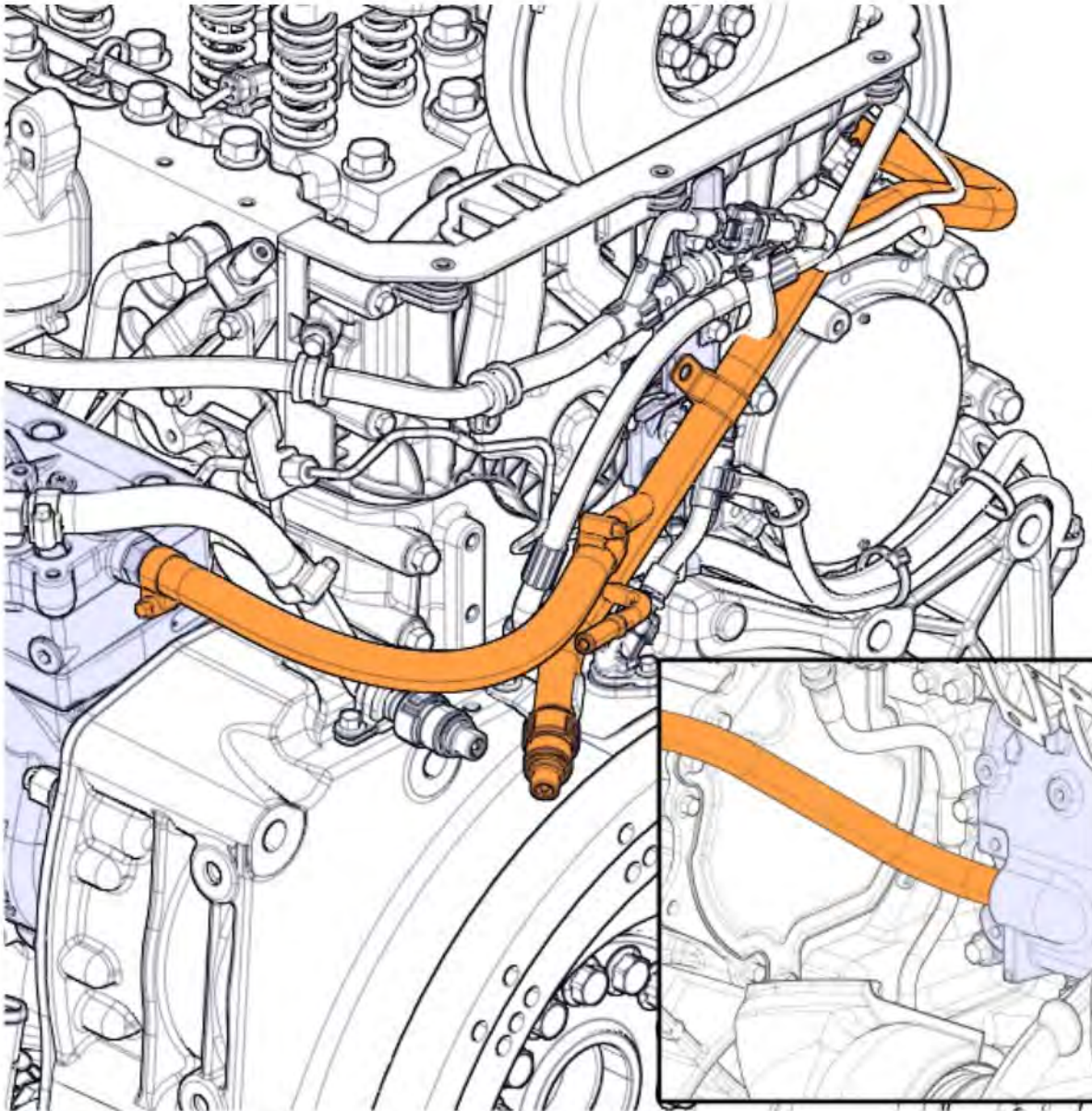

- | | |
|----|---------------------|
| 52 | Remove the screws. |
| 53 | Remove the clamp. |
| 54 | Remove the bracket. |

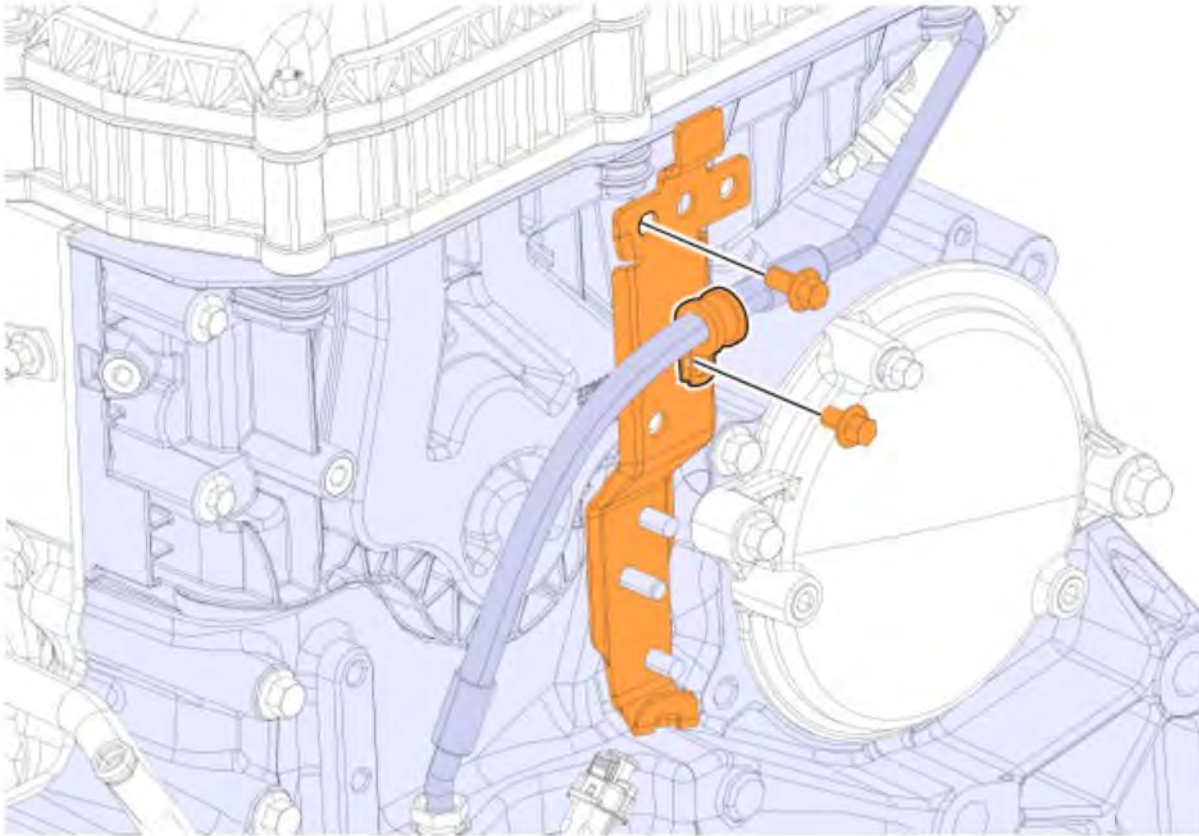

- | | |
|----|---|
| 55 | Disconnect the connector (1). |
| 56 | Remove the screw (2). |
| 57 | Remove the sensor and the heat shield. (3). |

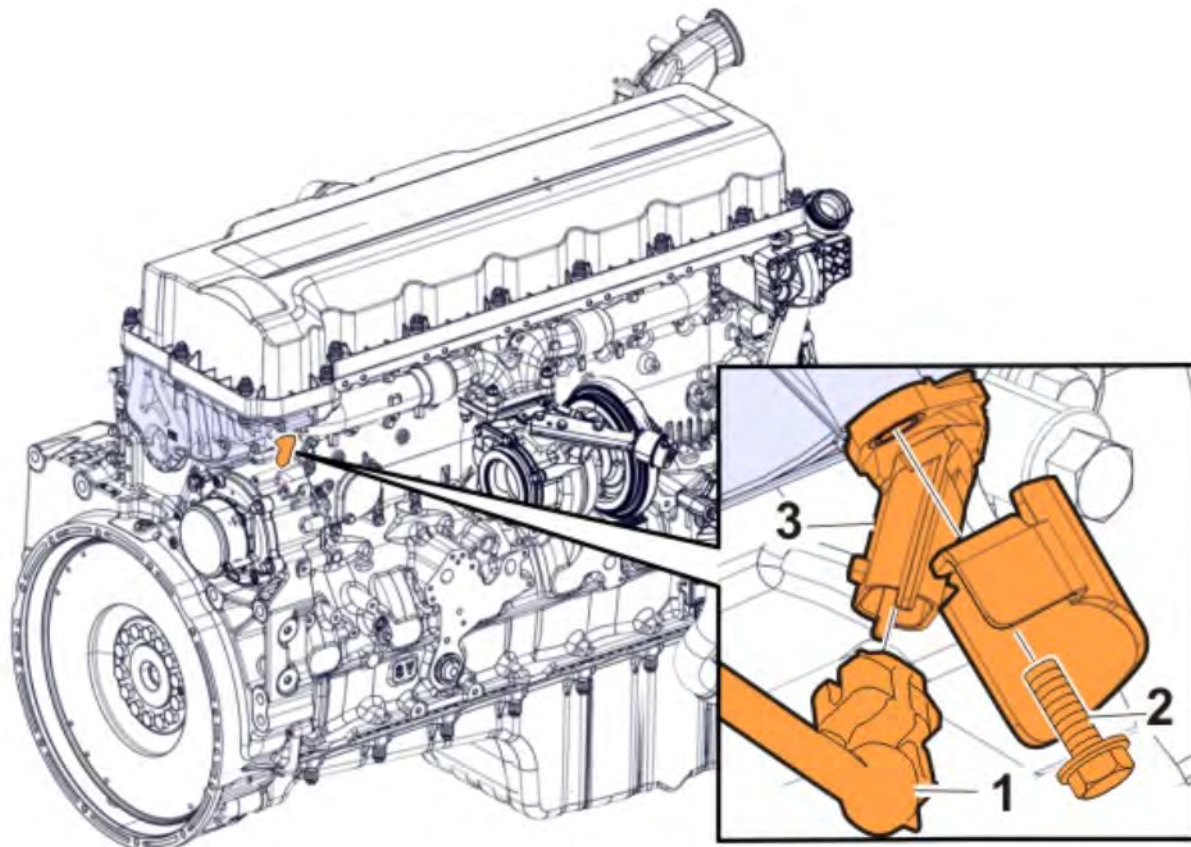

Copyright to this documentation belongs to the Volvo Group. No reproduction, copying, change, amendment or other similar disposal is entitled without prior written consent by the Volvo Group

The information contained herein is current at the time of its original distribution, but is subject to change. The reader is advised that printed copies are uncontrolled.

58 Be aware of possible shims.

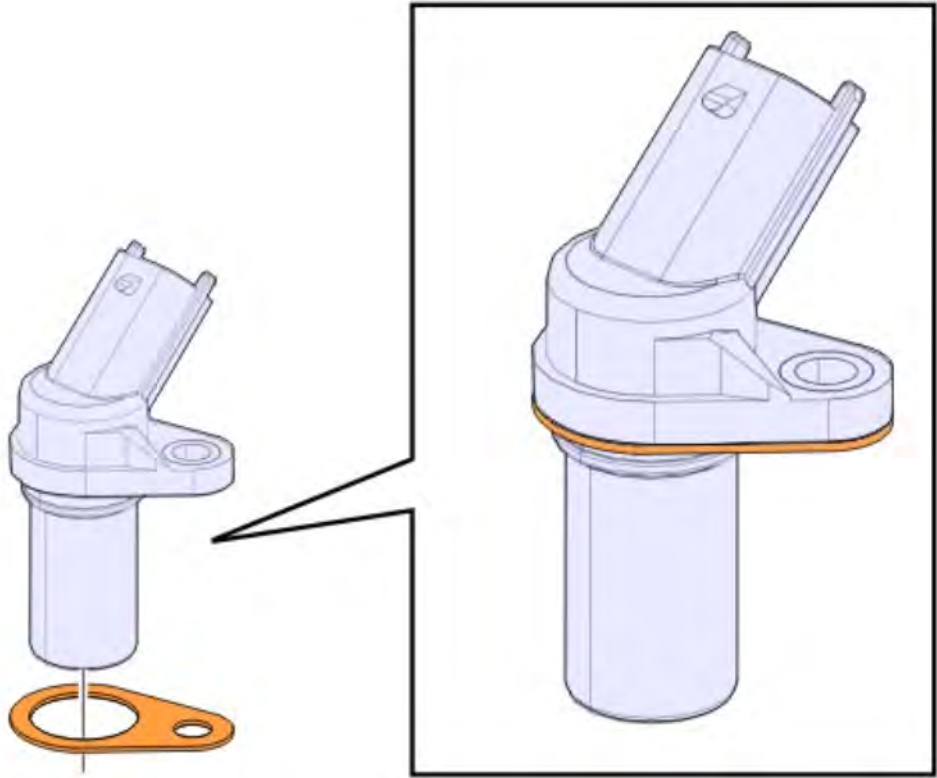

59 Disconnect the connector.

60 Remove the screws.

61 Remove the cover.

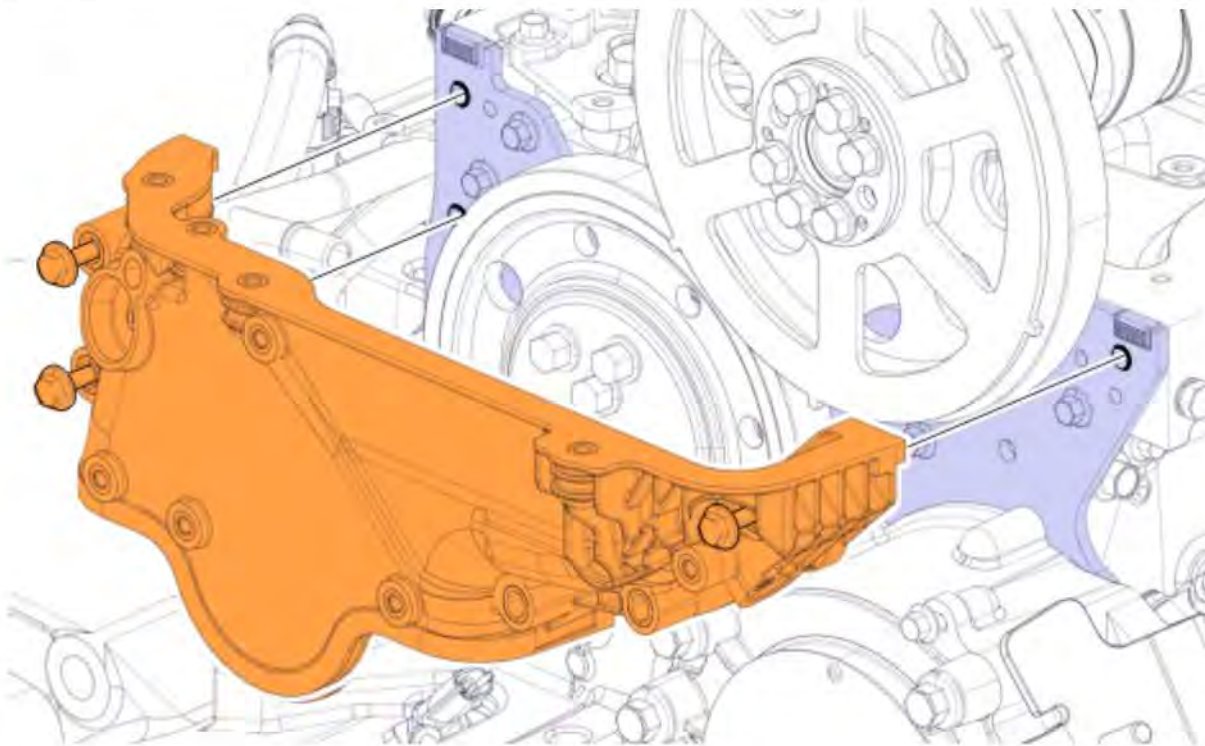

62 Perform this procedure when the condition below is met.

Copyright to this documentation belongs to the Volvo Group. No reproduction, copying, change, amendment or other similar disposal is entitled without prior written consent by the Volvo Group

The information contained herein is current at the time of its original distribution, but is subject to change. The reader is advised that printed copies are uncontrolled.

Conditions

- If not previously removed.

- ▶ Disconnect the connector.

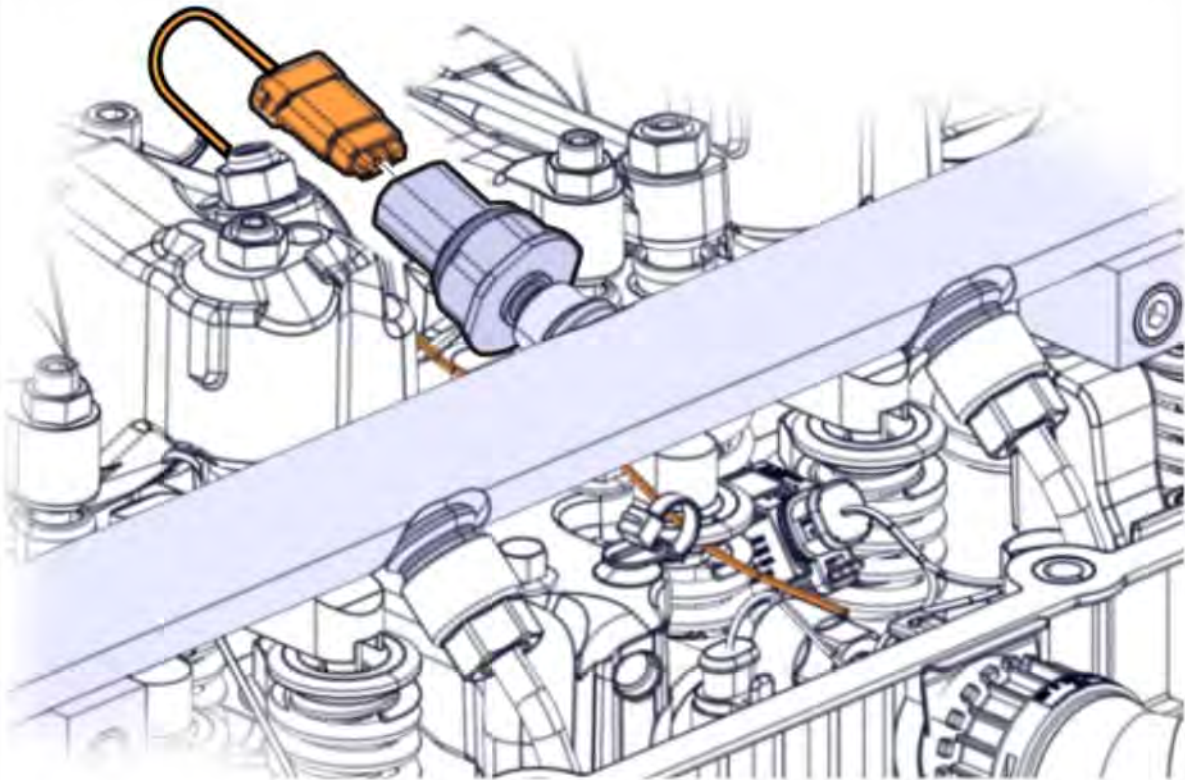

63 Clean around the sensor.

64 Remove the sensor.



CAUTION

Risk of material damage.

Component damage could occur if debris enters.

- ▶ Cover openings to prevent debris from entering.

65 Cover or plug openings immediately.

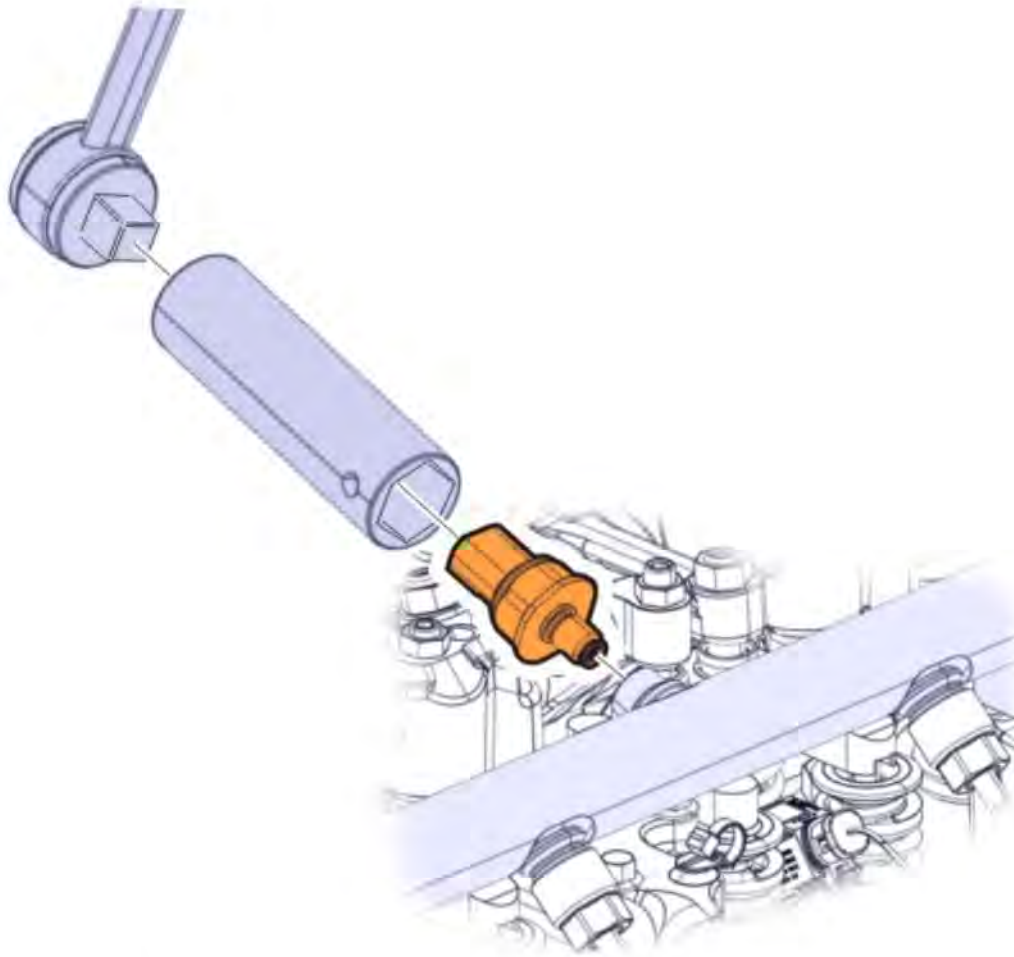

66	Remove the plug.
----	------------------

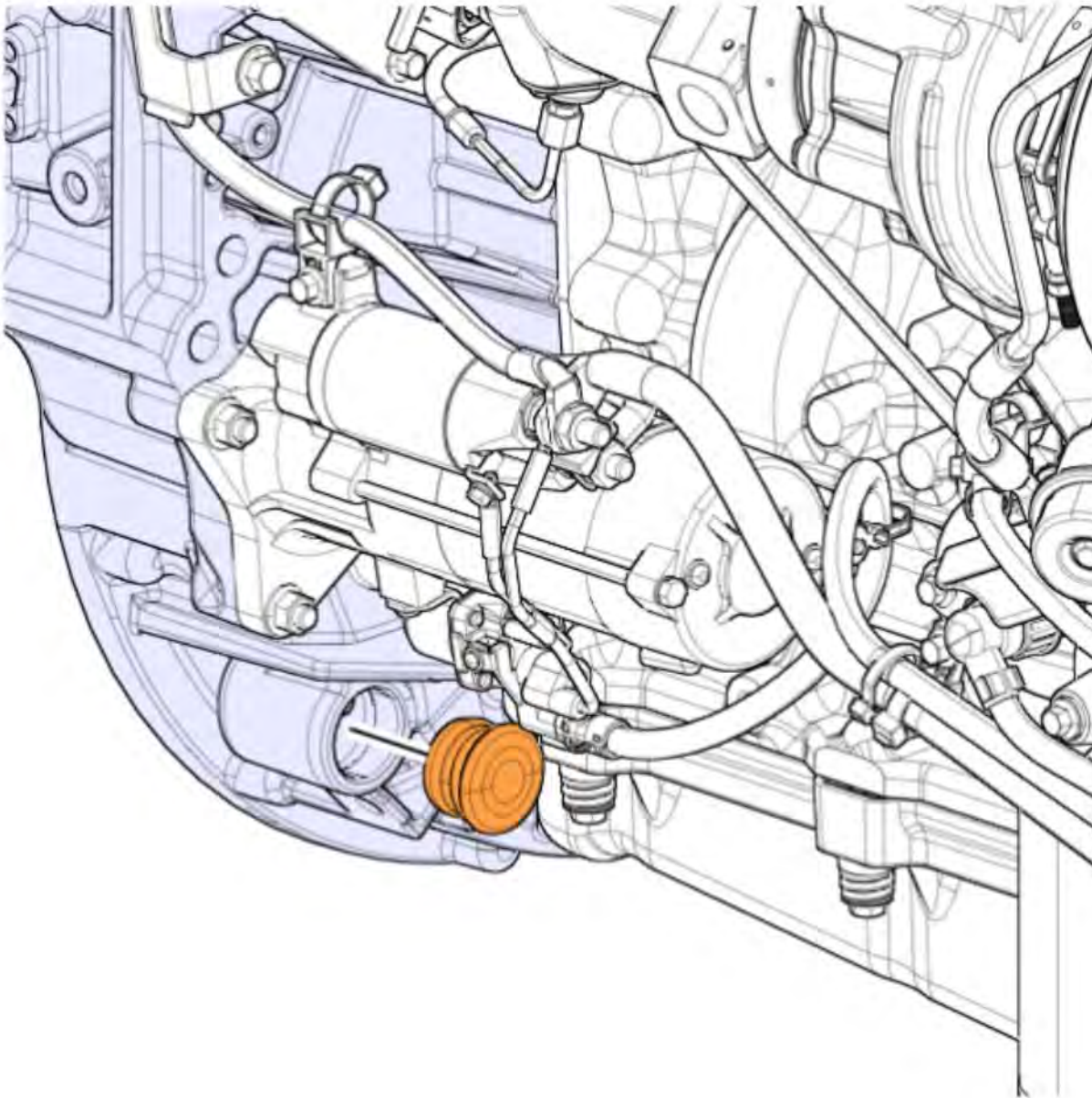

67	Install the cranking tool (A).	
Required material		
CRANKING TOOL		88840317

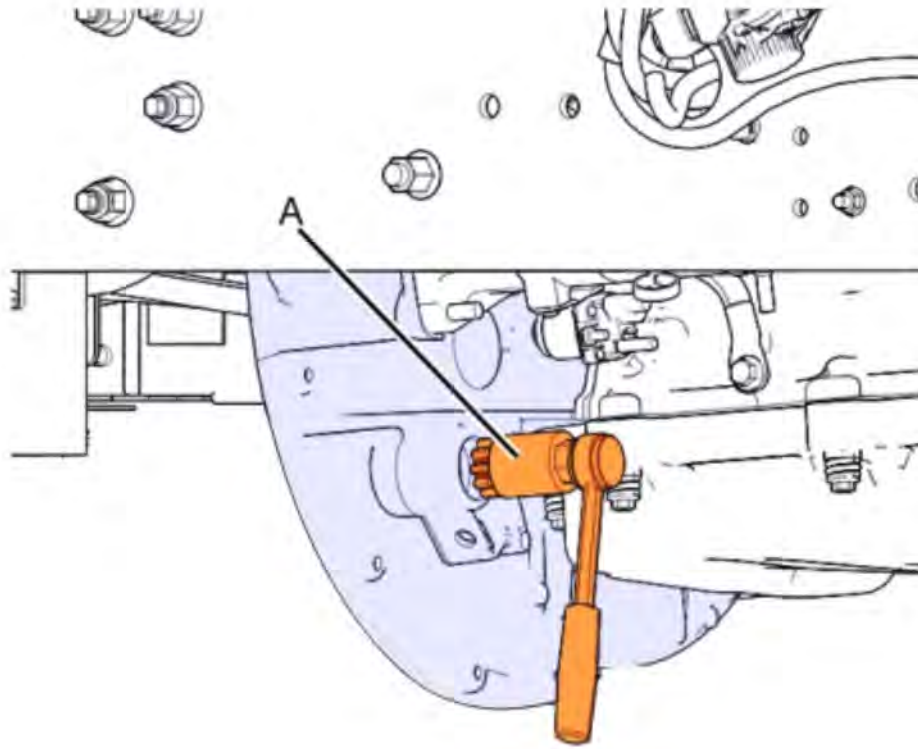

68	Remove the plug.
----	------------------

69	Check the marking (0).
----	------------------------

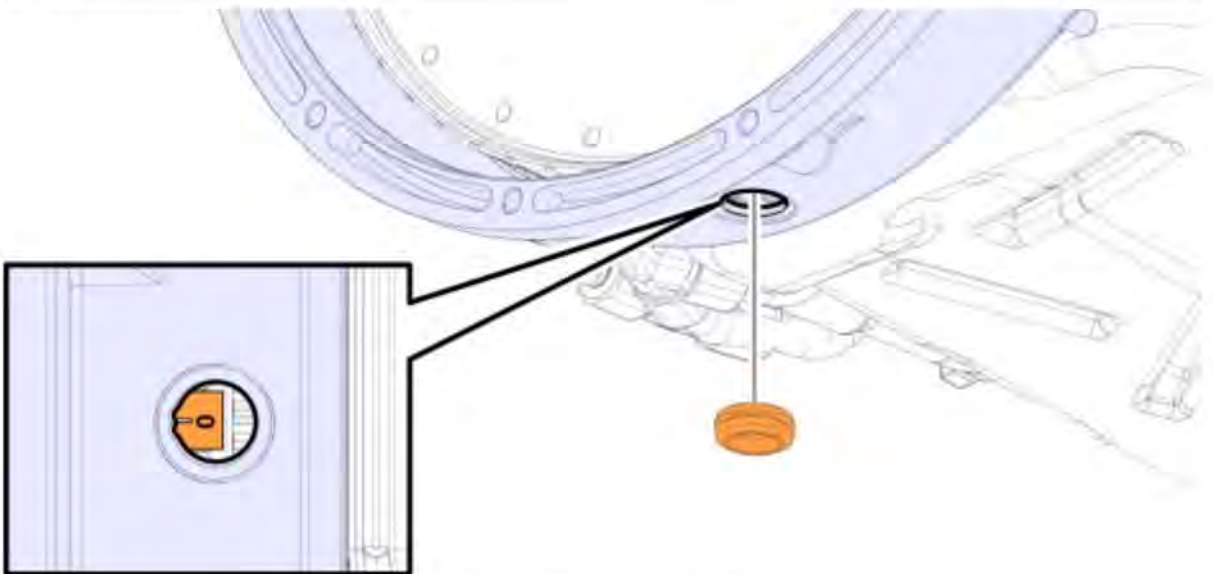

70	Perform this procedure when the condition below is met.
----	---

Conditions

- If the flywheel is not in the TDC (Top Dead Center) position.

- ▶ Rotate the flywheel to the TDC marking (0).

	Note Do not use power tools.
---	--

Copyright to this documentation belongs to the Volvo Group. No reproduction, copying, change, amendment or other similar disposal is entitled without prior written consent by the Volvo Group

The information contained herein is current at the time of its original distribution, but is subject to change. The reader is advised that printed copies are uncontrolled.

**Note**

Rotate the flywheel in the normal engine rotation direction.

71 Remove the screws and leaf springs.

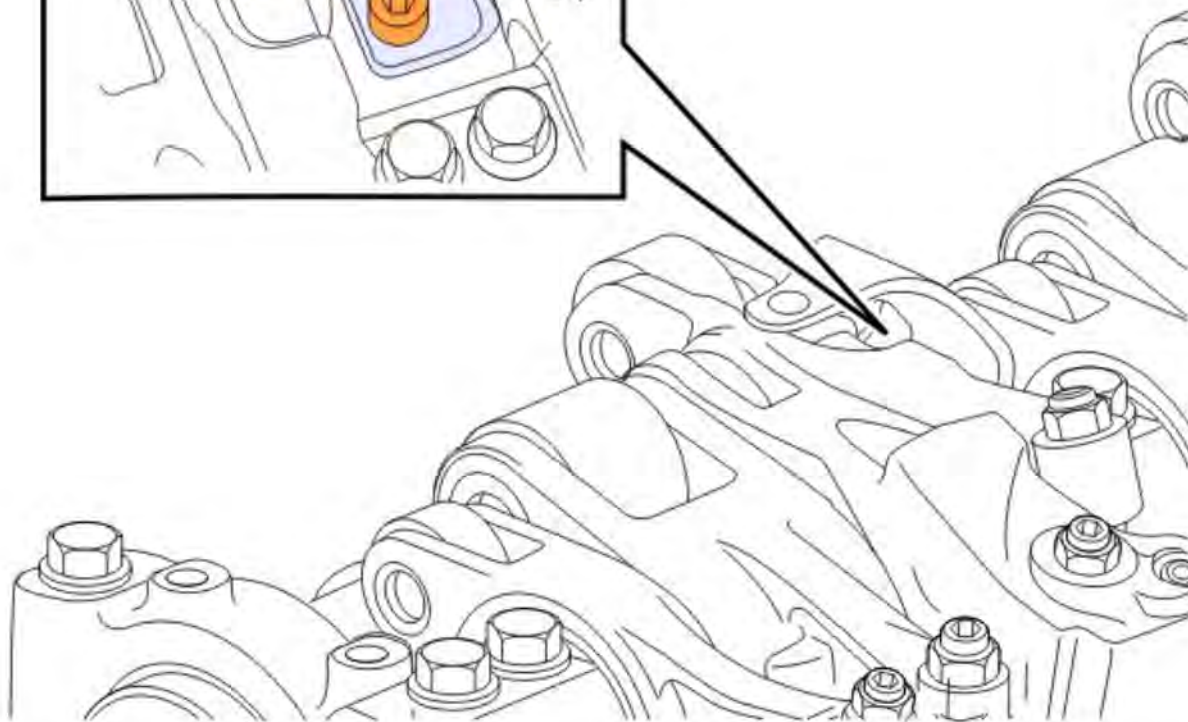
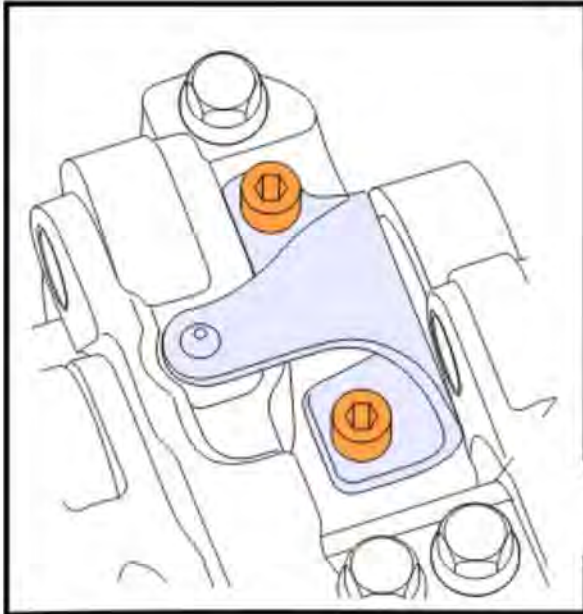

72 Remove the screw.

**Note**

The pipe is removed at a later stage along with the rocker arm shaft.

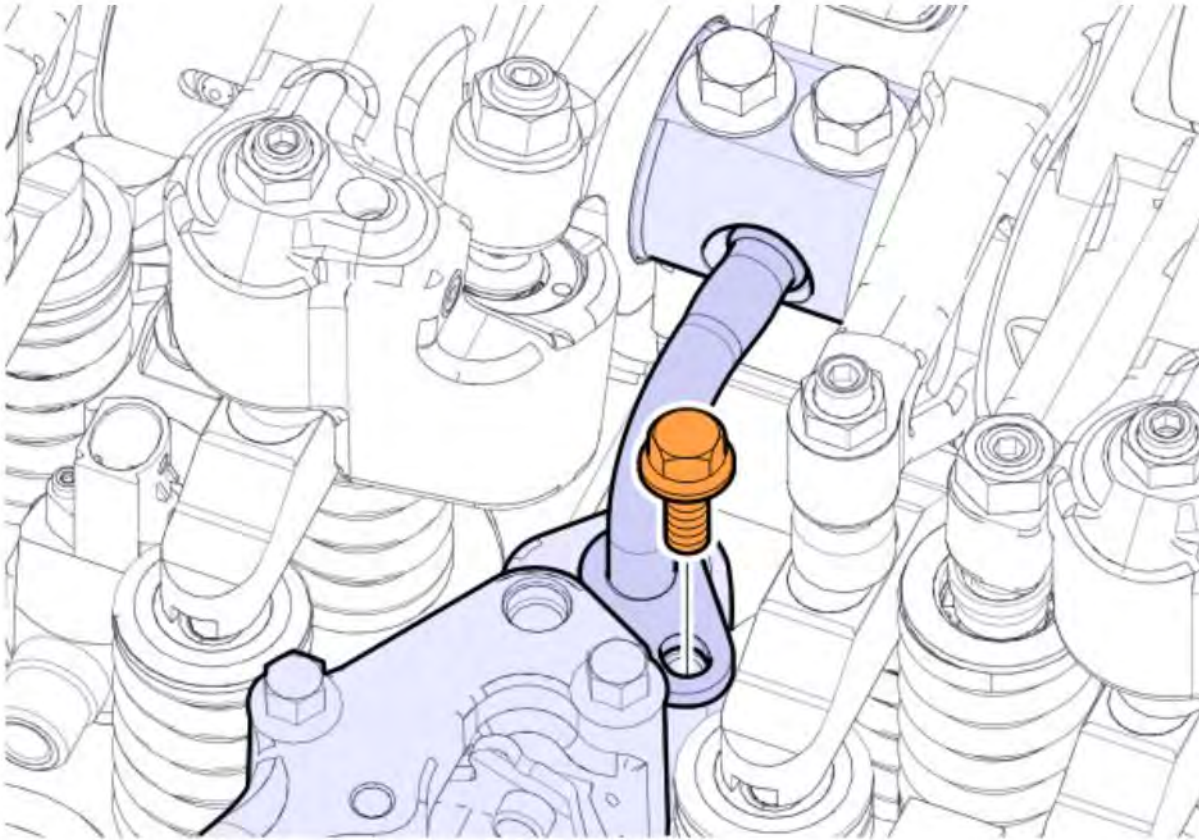

73	Loosen the adjustment screws.
-----------	-------------------------------

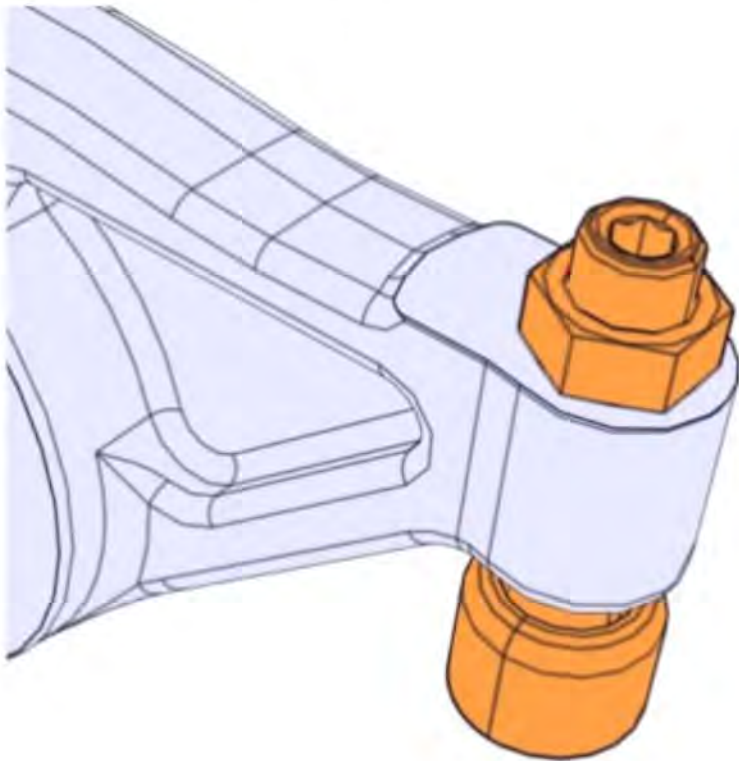

74	Loosen the screws.
-----------	--------------------

Tightening torque		
Rocker arm shaft, screw	1.	Remove screws: 1-3-5-7-9-11
		6 pcs
	2.	Remove screws: 13-2-12-4-10-6-8
		7 pcs

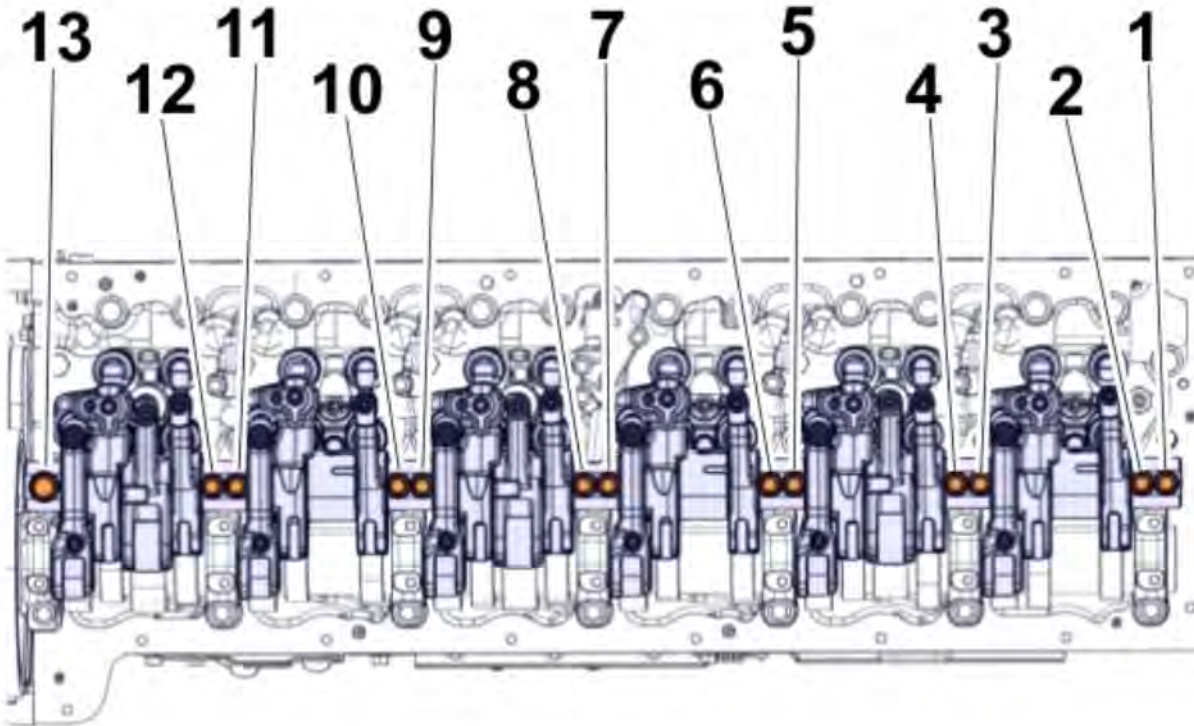

i	Note
	Loosen gradually in the sequence indicated.

75	Remove the screws.
-----------	--------------------

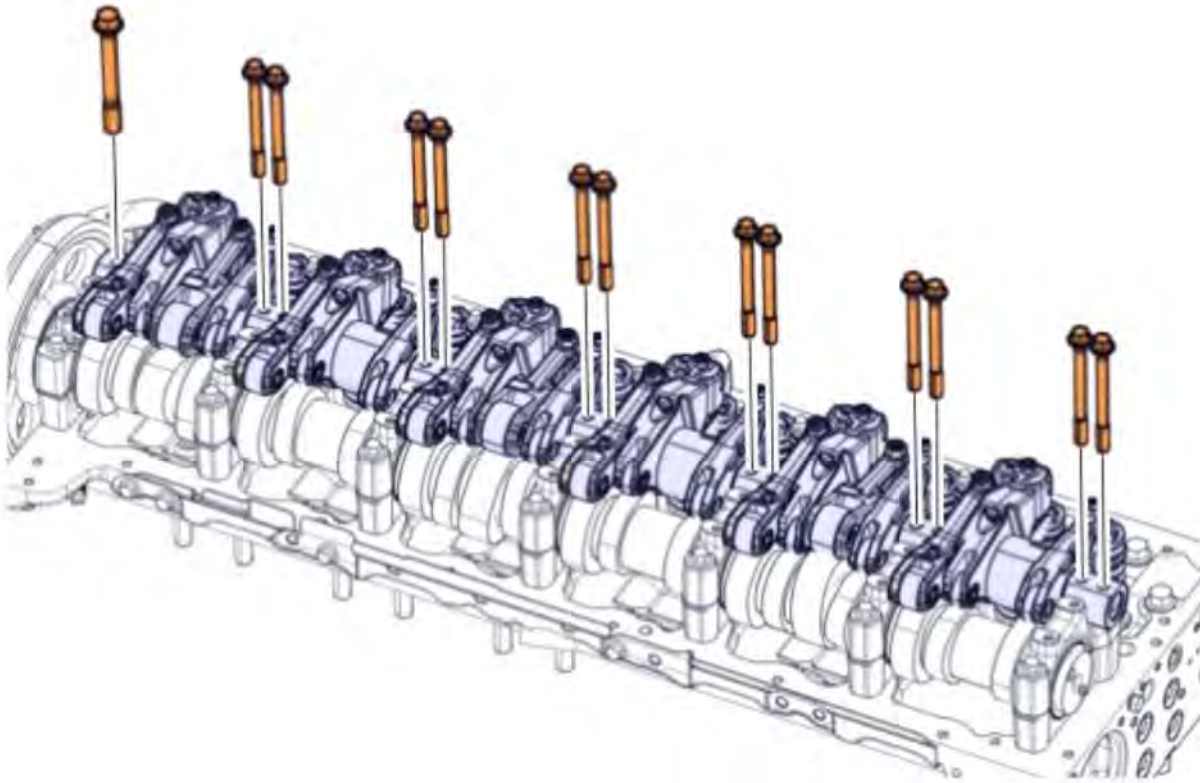

76	Secure the pistons.		
	<table border="1" style="width: 100%;"> <tr> <td style="width: 20px; text-align: center;">i</td> <td>Note Use cable ties.</td> </tr> </table>	i	Note Use cable ties.
i	Note Use cable ties.		

77	Install the lifting tool.		
	Required material		
	<table border="1" style="width: 100%;"> <tr> <td style="width: 40%;">LIFTING TOOL</td> <td style="text-align: center;">85109250</td> </tr> </table>	LIFTING TOOL	85109250
LIFTING TOOL	85109250		

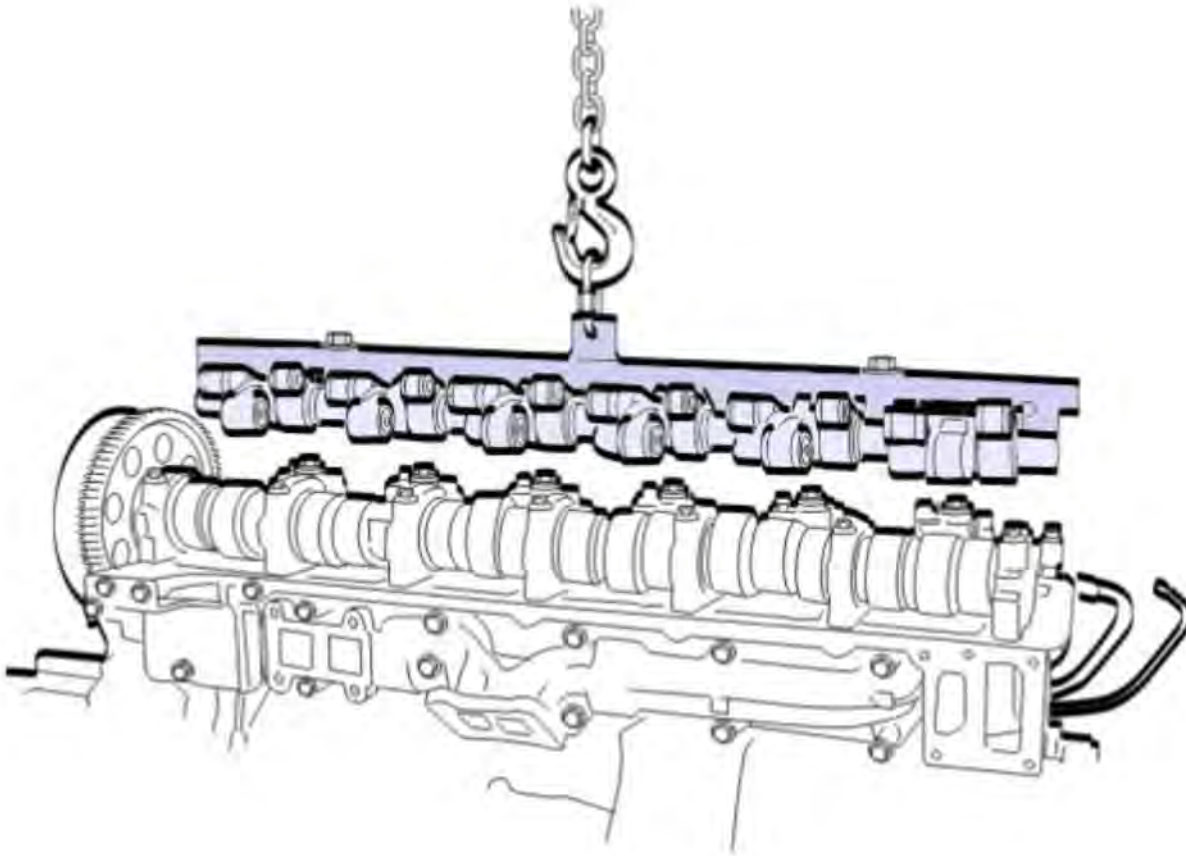

78	Remove the rocker arm shaft.
----	------------------------------

79	Remove the pipe.
----	------------------

**Note**

Discard the pipe.

Do not reuse.

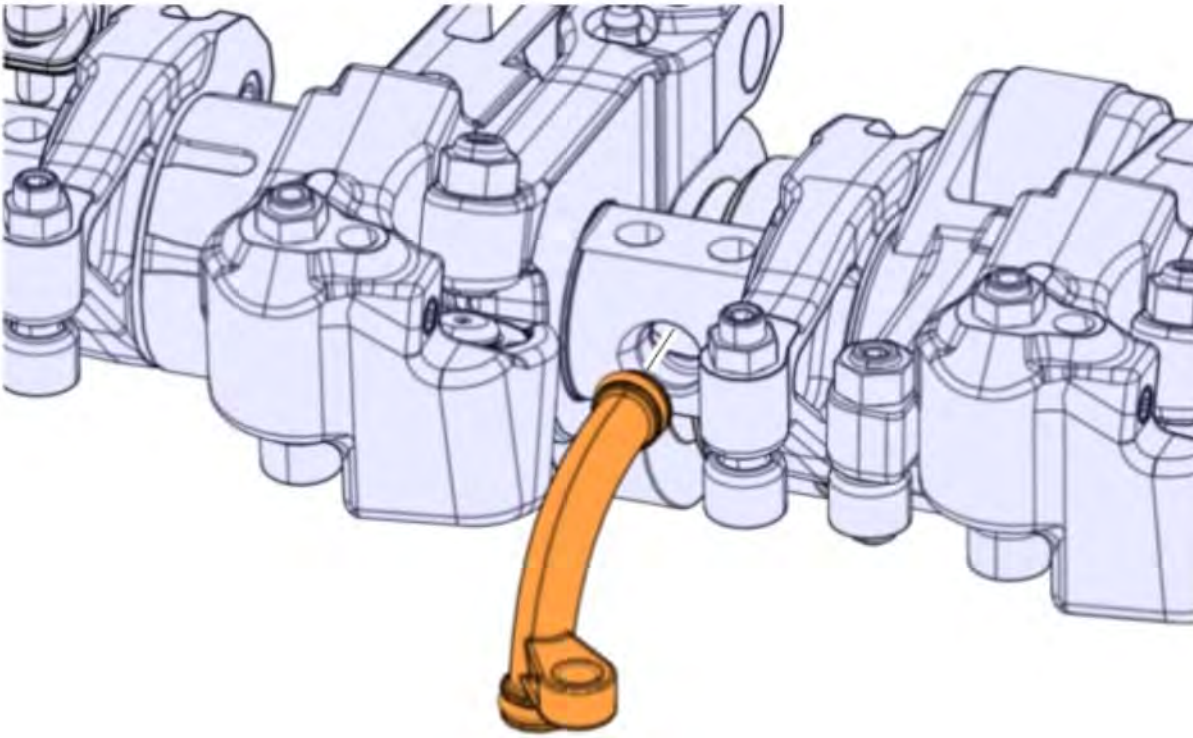

80	Remove the screws.
----	--------------------

81	Remove the gear and sensor wheel.
----	-----------------------------------

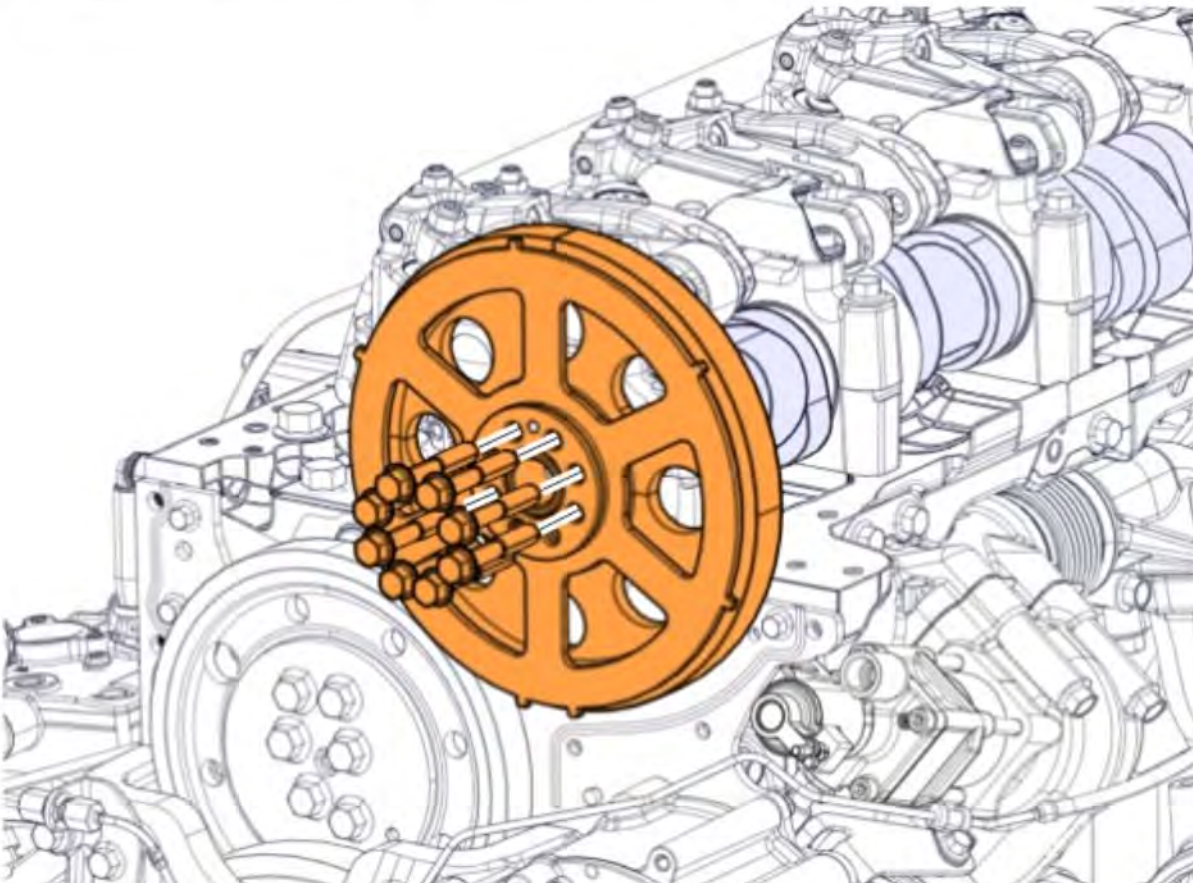

82 Remove the screws.



Note

Check that the camshaft caps are marked up.

83 Remove the caps.

Required material

A	IMPACT WRENCH	9996400
B	EXTRACTOR	88800420

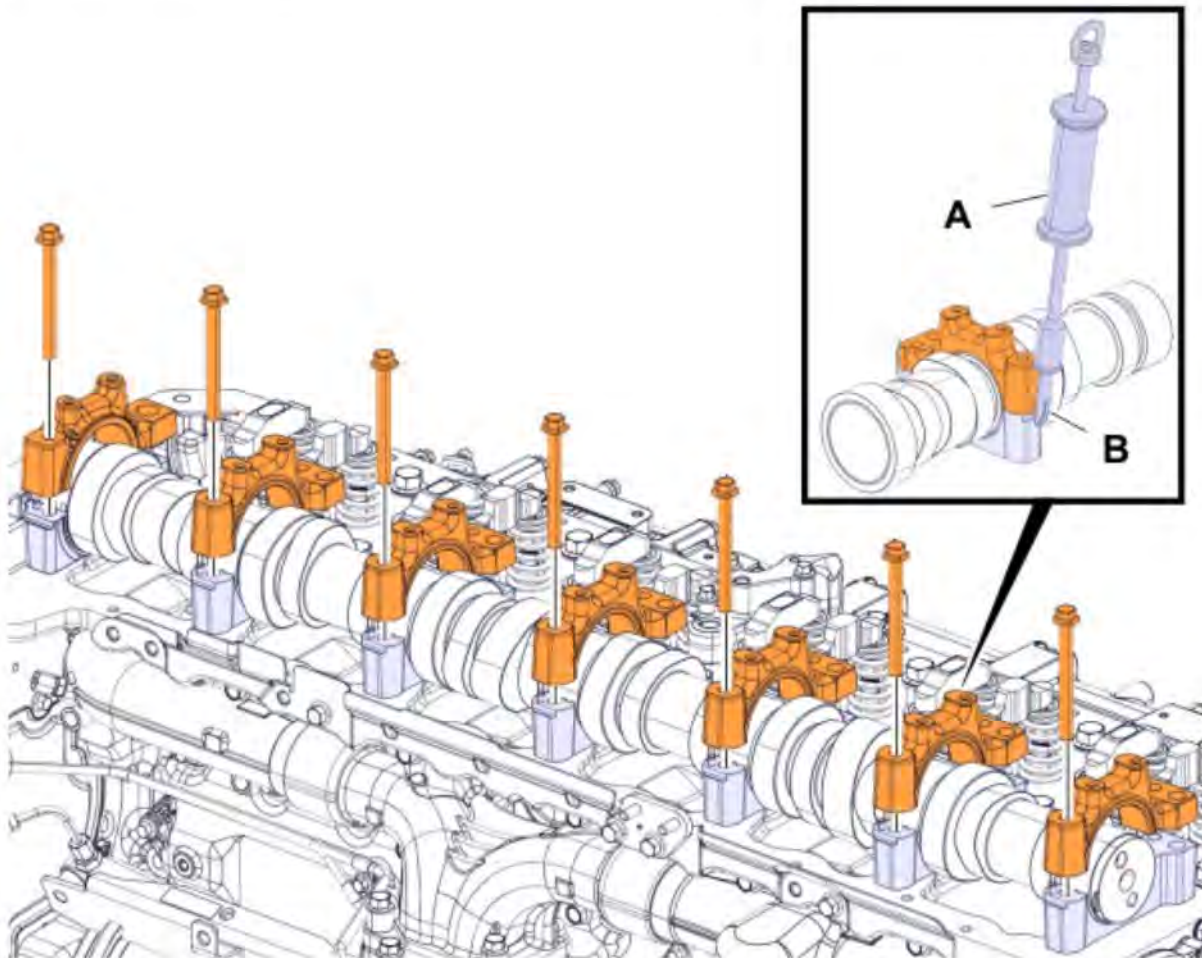

84 Install the tool (A).

Required material

LIFTING TOOL	9998264
--------------	-------------------------

85 Remove the camshaft.