

- ATTENTION:**
- GENERAL MANAGER
 - PARTS MANAGER
 - CLAIMS PERSONNEL
 - SERVICE MANAGER

IMPORTANT - All Service Personnel Should Read and Initial in the boxes provided, right.

© 2024 Subaru of America, Inc. All rights reserved.



QUALITY DRIVEN® SERVICE

SERVICE BULLETIN

APPLICABILITY: 2021-24MY Legacy & Outback
2017-24MY Impreza & Crosstrek

NUMBER: 09-123-24

DATE: 05/03/24

SUBJECT: DTC P0087 / High-Pressure Fuel Pump Design Change

INTRODUCTION:

This bulletin announces the design change made to the high-pressure fuel pump developed to prevent DTC P0087 (Fuel Rail/System Pressure – Too Low Bank 1). The performance of the internal discharge valve of the pump has been optimized to help prevent any unstable fuel pressure caused by engine vibrations. If DTC P0087 is found to be detected by the Engine Control Module (ECM), the high-pressure fuel pump will require replacement.

PRODUCTION CHANGE INFORMATION:

The new high-pressure fuel pumps have been incorporated into vehicle production as per the table below.

Model	Starting VIN
Legacy	R3007808
Outback	R3136202
Crosstrek (Japan Production)	RH219194
Crosstrek (SIA Production)	R3710846

PART INFORMATION:

REMINDER: Always order the most up-to-date replacement parts based on the specific VIN being repaired.

Part Description	Model	Part Number
PUMP ASSY-FUEL, HIGH PRESSURE	Impreza, Crosstrek, & Forester	16625AA071
PUMP ASSY-FUEL, HIGH PRESSURE	Outback & Legacy	16625AA190

CAUTION: VEHICLE SERVICING PERFORMED BY UNTRAINED PERSONS COULD RESULT IN SERIOUS INJURY TO THOSE PERSONS OR TO OTHERS.

Subaru Service Bulletins are intended for use by professional technicians ONLY. They are written to inform those technicians of conditions that may occur in some vehicles, or to provide information that could assist in the proper servicing of the vehicle. Properly trained technicians have the equipment, tools, safety instructions, and know-how to do the job correctly and safely. If a condition is described, DO NOT assume that this Service Bulletin applies to your vehicle, or that your vehicle will have that condition.

Subaru of America, Inc. is ISO 14001 Compliant

ISO 14001 is the international standard for excellence in Environmental Management Systems. Please recycle or dispose of automotive products in a manner that is friendly to our environment and in accordance with all local, state and federal laws and regulations.

Continued...

One Time Use Parts		
Engine	Part Description	Part Number
2.0	PIPE ASSEMBLY-FUEL DELIVERY	17540AA390
	GASKET-INTAKE MANIFOLD	14035AA690
2.4	PIPE ASSEMBLY-FUEL DELIVERY	17540AA430
	GASKET-INTAKE MANIFOLD	14035AA74A
2.5	PIPE ASSEMBLY-FUEL DELIVERY	17540AA450
	GASKET-INTAKE MANIFOLD	14035AA78A

NOTE: ALWAYS confirm all required parts are on hand prior to beginning any service procedures.

SERVICE PROCEDURE / INFORMATION:

IMPORTANT: Inspect and record the part number located on the top of the high pressure pump. Verify the NEW part number is not installed prior to replacement.

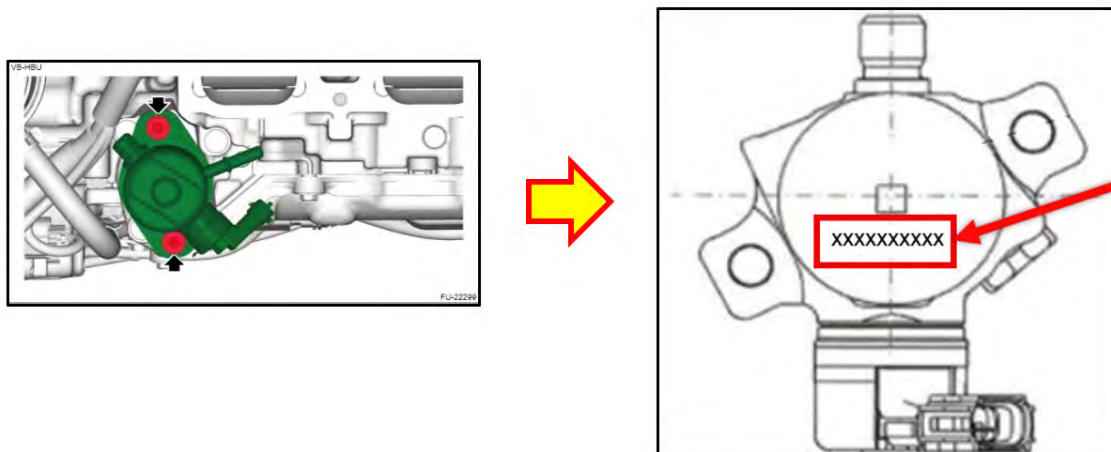

The service procedures for high pressure fuel pump replacement remain unchanged. Always refer to the applicable Service Manual and review the full requirements of the repair being performed. The Service Manual procedures contain information critical to performing an effective repair the first time, every time. This includes but is not limited to important SAFETY precautions, proper inspection criteria, necessary special tools, required processes and related one-time-use parts needed for a complete and lasting repair.

WARRANTY / CLAIM INFORMATION:

For vehicles within the Powertrain Limited Warranty period, an applicable Emission Warranty period, or covered by an active Subaru Added Security Classic or Gold plan, this repair may be submitted using the following claim information:

Labor Description	Labor Operation #	Repair Code	Labor Time	Engine Size
HIGH PRESSURE FUEL PUMP, PLUNGER/O-RING R&R	B440-086	DGC-42	1.2h	2.0L
			1.7h	2.5L
			2.2h	2.4L

Continued...

IMPORTANT REMINDERS:

- SOA strongly discourages the printing and/or local storage of service information as previously released information and electronic publications may be updated at any time.
- Always check for any open recalls or campaigns anytime a vehicle is in for servicing.
- Always refer to STIS for the latest service information before performing any repairs.