

Levante Rear Differential Oil Seals Replacement

DATE: May 21, 2024

The purpose of this document is to provide guidelines for managing concerns regarding oil leakage from the side/axle seals of the rear differential. In these cases, it is recommended to replace only the oil seals instead of the entire assembly. This procedure is permitted only for Levante vehicles, both within and beyond the warranty period. BOL opening as "Factory Information" is required with pictures of the leakage before proceeding with the seal replacement.

MODELS: M161 Levante (All MY).

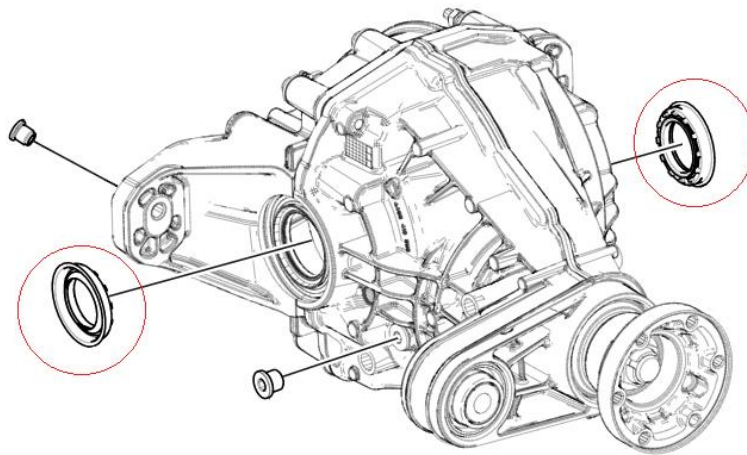

Maserati has established the spare parts and procedures necessary for replacing rear differential seals in the event of oil leakage from one or both seals. This intervention is permitted exclusively for M161 vehicles, both within and beyond the warranty period.

Seal replacement is authorized only if the differential is affected solely by oil leakage. If these leaks are accompanied by other issues (e.g., internal noise, oil leakage from other areas), the entire differential must be replaced.

For further details, please refer to the spare parts catalog and technical documentation available on Modis.

TECHNICAL SERVICE OPERATIONS