



Service Bulletin

Bulletin No.: 22-NA-173

Date: May, 2024

INFORMATION

Subject: Information on Transmission Fluid Leak

Brand:	Model:	Model Year:		VIN:		Engine:	Transmission:
		from	to	from	to		
Chevrolet	Corvette	2020	2024	—	—	All	All

Involved Region or Country	North America, Europe, Israel, Middle East, Japan, Thailand, Australia/New Zealand
Condition	Some customers may comment that transmission fluid can be seen under the vehicle.
Information	The following photos are only for informational purposes and to help guide technicians to known areas of possible leaks. Testing in the photos used fluorescent dye to aid in better photography. These transmissions were scrapped after dye was added. At no time should a technician in the field add dye to the M1L transmission. Technicians should only follow the trace powder diagnosis procedure recommended in <i>Fluid Leak Diagnosis</i> .

Important: Service agents must comply with all International, Federal, State, Provincial, and/or Local laws applicable to the activities it performs under this bulletin, including but not limited to handling, deploying, preparing, classifying, packaging, marking, labeling, and shipping dangerous goods. In the event of a conflict between the procedures set forth in this bulletin and the laws that apply to your dealership, you must follow those applicable laws.

Examples of Transmission Leak Areas of Concern

When performing a leak test always be sure to clean the transmission thoroughly prior to powder testing. Make an attempt to protect the transmission labels from any type of solvent that may be used. Solvents can erase the print on the labels and make the transmission difficult to identify. A great opportunity to recreate the leak after powder application is to perform the Hydraulic System Flush Procedure in service information document 6412296 multiple times until a leak is visible. Because of the elevated RPMs in this test and the vehicle being stationary, always monitor engine temperature. It may also be necessary to run the vehicle with the rear wheels spinning on the lift to reproduce the leak. It will be necessary to disable the ABS system if this is the case. Make sure the vehicle has been supported by the lift properly with the recommended lift attachments and that the wheels are clear of the floor. If the coolant temperature is excessive and fans continue to run, it may be necessary to allow the vehicle to cool before continuing testing.

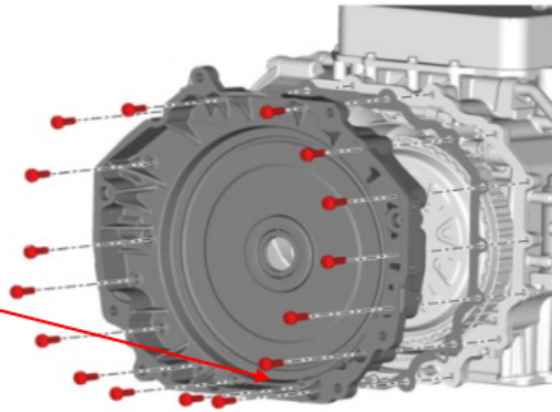
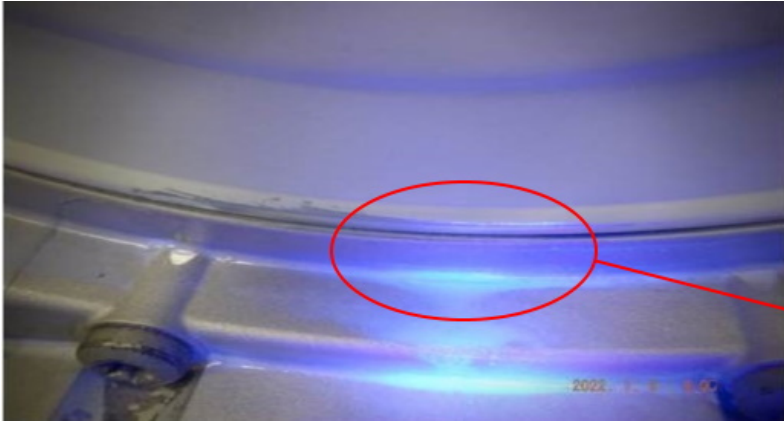

A leak between sealing plate and Bell Housing.

- If this leak is found, it will be necessary to replace the clutch differential housing assembly. Be sure to

also order all the one-time use parts in the service information repair instructions.

6142752

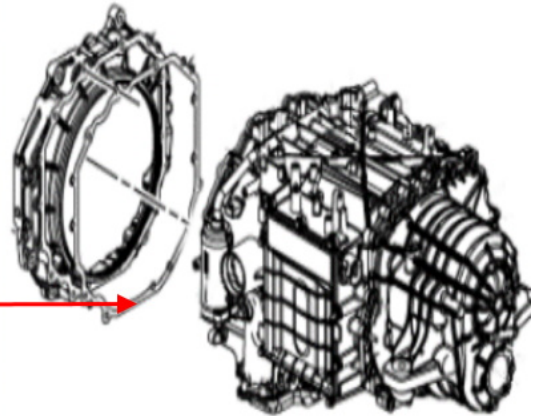
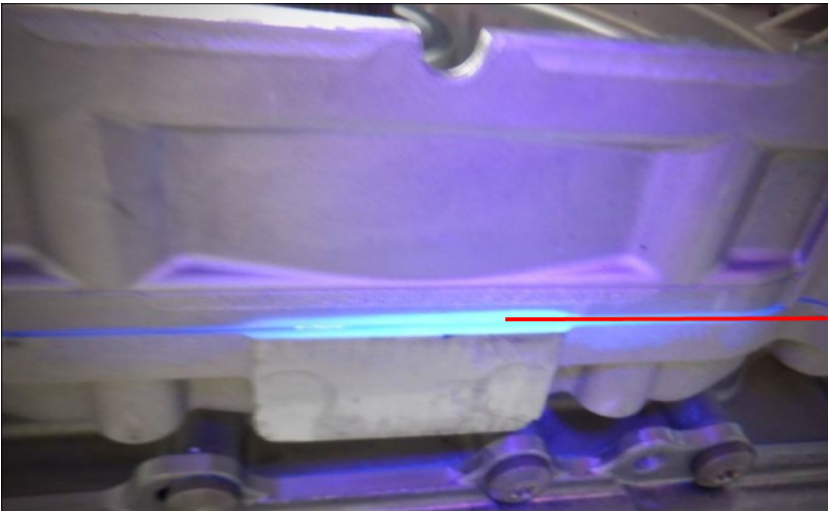

Leaks at the gasket area between the clutch and differential cover and the main case. There is a gasket in this area.

- The gasket in this area is serviceable. Be sure to follow service information for which parts are one-time use and order these components. Also be sure to inspect the machined surfaces and attempt to verify that the leak is actually caused by the gasket rather than a bolt torque or surface finish issue that may cause a duplicate repair.

Video (Oil Leak) (SIO# 6460614)

6142966

This video above shows transmission case porosity, issue during testing.



4823455

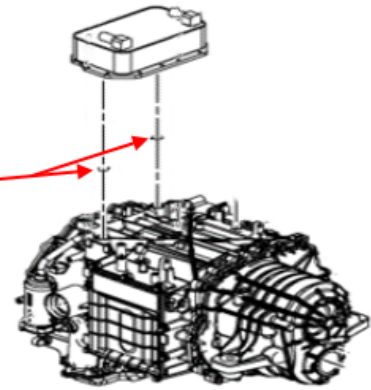
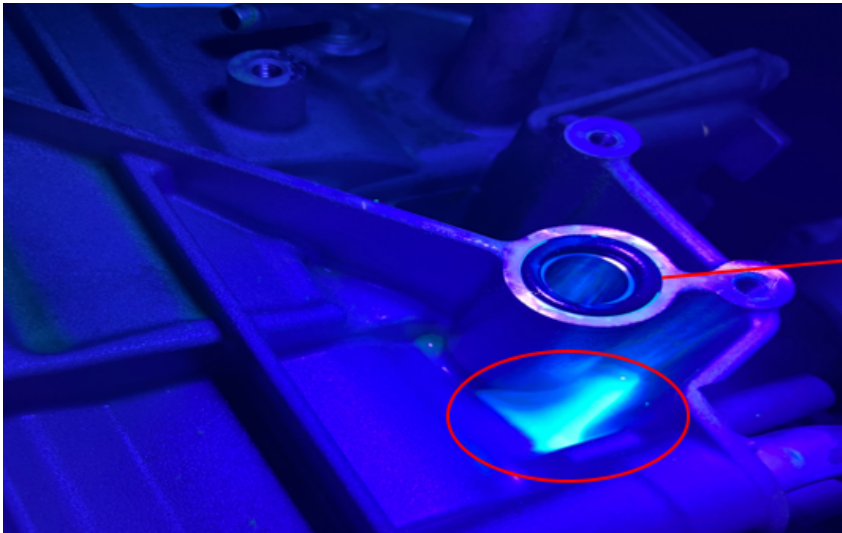

This is an area that is often mis-diagnosed as a transmission cooler issue. It was found that in most cases, leaks in this area are caused by transmission case porosity under the transmission cooler. Proper diagnosis in this area would be to inspect the cooler for any signs of physical damage. If no damage is found, carefully remove the cooler, and inspect the two (14) O-rings for damage and proper sealing. The dye photo shows a puddle of oil just under the cooler sealing

6142841
area in the pocket, the fluid is being pushed through the case due to material porosity. This concern will require transmission assembly replacement. This leak can often be confused with transmission SAV cover and MCV cover leaks because the leaking fluid from above tends to get captured by the rails and follow that path. Be sure to powder test these areas well and with the understanding that fluid tends to flow down across the transmission.

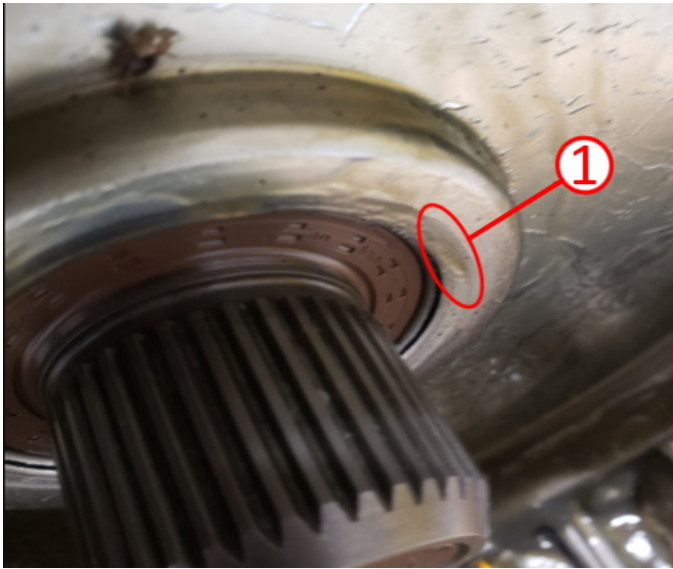

A small crack in the clutch cover area (1) of the input shaft seal can be mis-diagnosed as an input shaft seal leak (3). Additional cases have been verified at the input shaft end plug/seal (2), was damaged during transmission to engine mating. The input shaft end plug and the input shaft seal can be serviced separately if a crack is not witnessed in the clutch cover. If the area is cracked the clutch differential housing assembly will need replacement as an assembly. The input shaft end plug does not come with the clutch differential cover assembly.

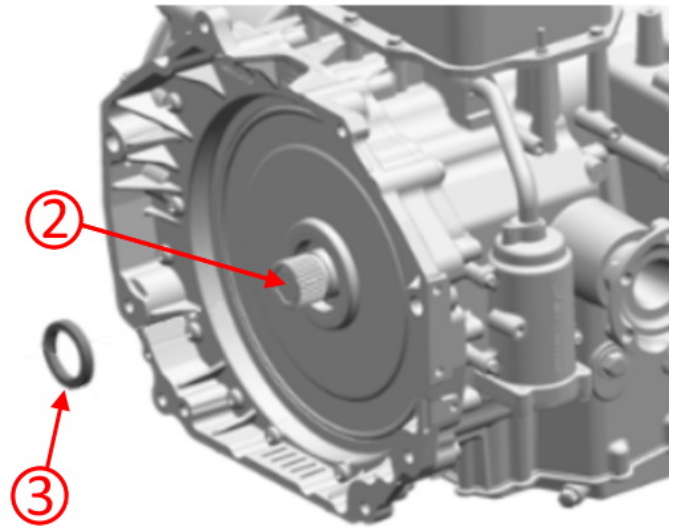

6142814

Porosity concerns with the differential cover. This area needs to be carefully powder tested to verify the leak is not associated with the cover seal (16) or the dog-bones and seals. Technicians have stated that they have found the cover double-gasketed when they confused the metal differential shims with what they thought were gaskets. All shims need to be re-installed to retain proper bearing load on differential. If porosity is found in the cover, the transmission will require replacement.

Note: Due to a revision in service information, the engine cradle no longer needs to be removed to replace the auxiliary canister filter housing. This led to an update in the labor time study and the labor hours for this repair have been adjusted to reflect this.

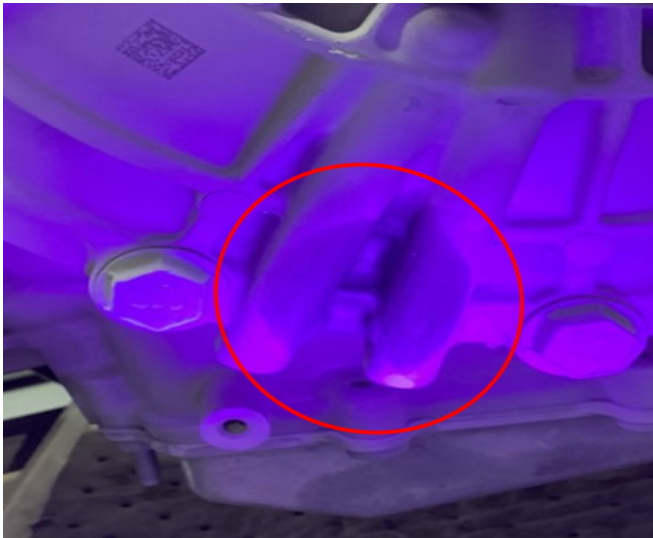

6142818

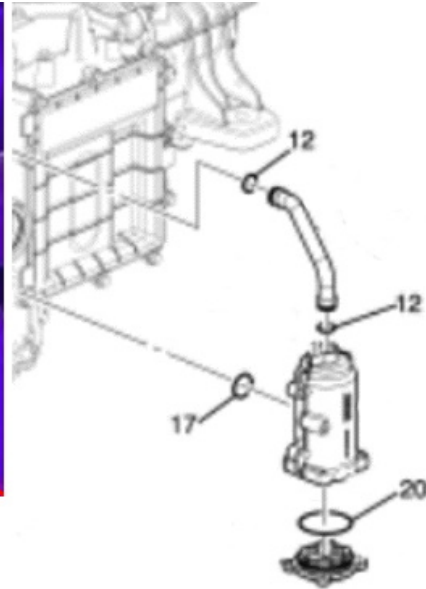
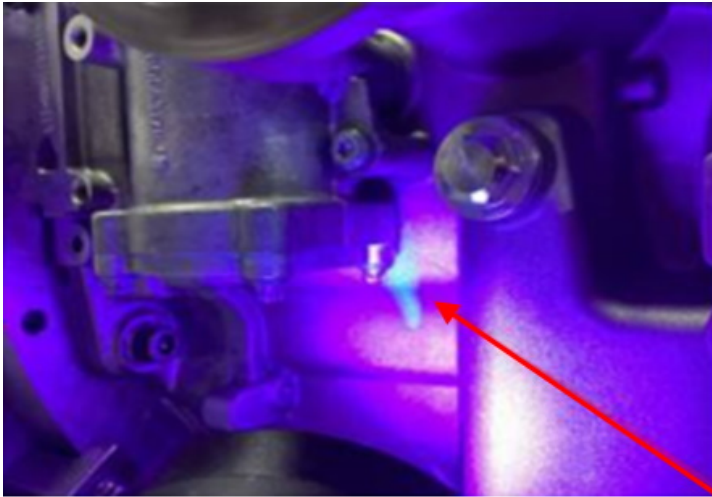

6142744

The auxiliary canister filter can create leaks in several areas. The most common area is cover seal (20), O-ring installation issues after filter replacement. Other areas of concern can be found at the are O-rings (12) and (17).

Note: Inspect the cover prior to replacement of the seal for porosity issues in the O-ring groove area.

The photo above shows the red arrow pointing to a case porosity issue that was found lying behind the auxiliary canister housing. With any case porosity issue, the transmission will require replacement. The photo below shows the red arrow pointing to the auxiliary canister filter cover O-ring groove. There have been known cases with porosity found in the O-ring groove causing leaks in this area.



6456550

Transmission rear cover area leak. (Tremec name plate):

- If there seems to be a leak in this area, be sure to clean the area thoroughly. Residual oil can get trapped between the outer surface and the O-ring.
- After powder testing, if a leak re-occurs, remove the cover, and inspect the O-ring for damage.
- If no obvious damage is found with the O-ring, be sure to inspect the cover itself for porosity issues in the O-ring groove. It is critical to identify the difference between a leak and dampness.

- The red arrow in the graphic above, points to the oil dam that may come off when the cover (Tremec name plate) is removed. If it is removed, it is necessary to replace the associated O-ring and align properly with cover prior to re-assembly. Damage will occur if the oil dam is not aligned to match the cover.

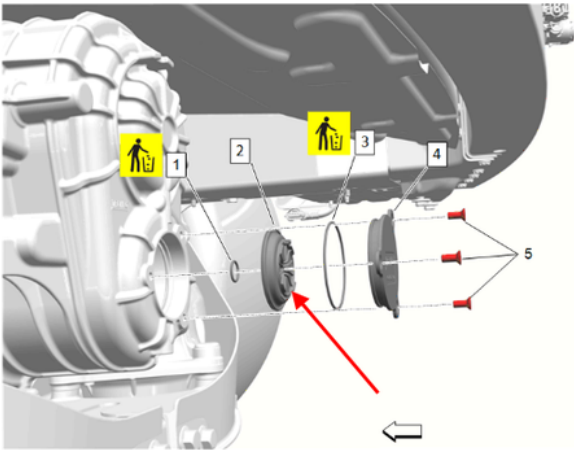

6637446

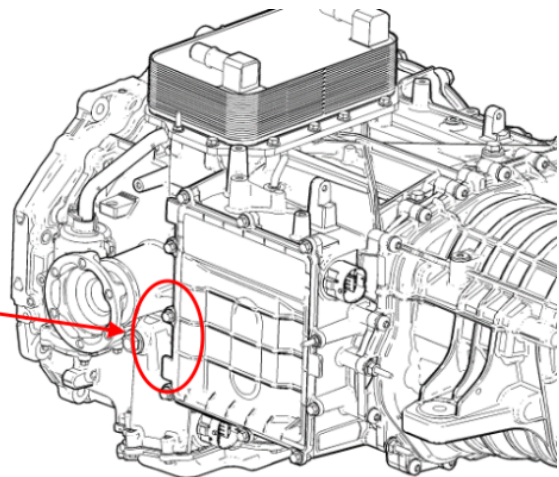
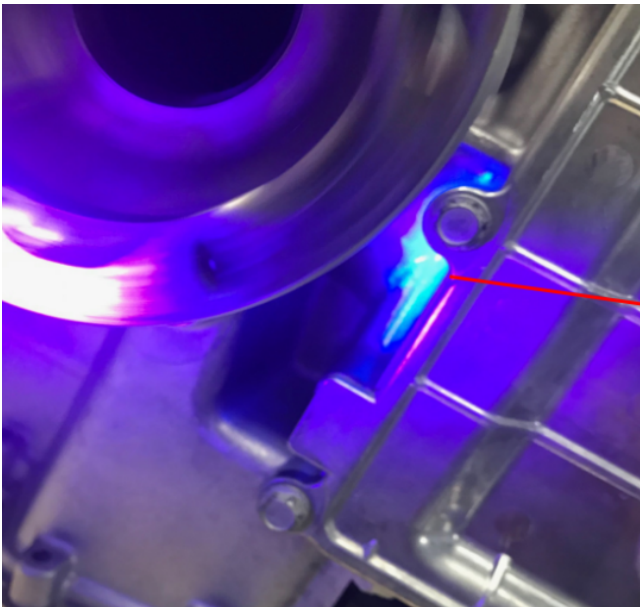

6142979

Transmission case porosity concerns have been found in the SAV cover area of the transmission. This is often the most misdiagnosed leak on this transmission. The fluid seeps through the case and runs down between the SAV cover and case to the pan rail, and often the transmission pan, and gasket get replaced, then the SAV cover, and finally the transmission. Often

these leaks will not develop by just allowing the engine to run. Usually, the vehicle will need to be lifted safely on a hoist with the wheels raised to allow the vehicle to run in gear. This action applies to most porosity leaks.

New Examples of Transmission Leak Areas of Concern

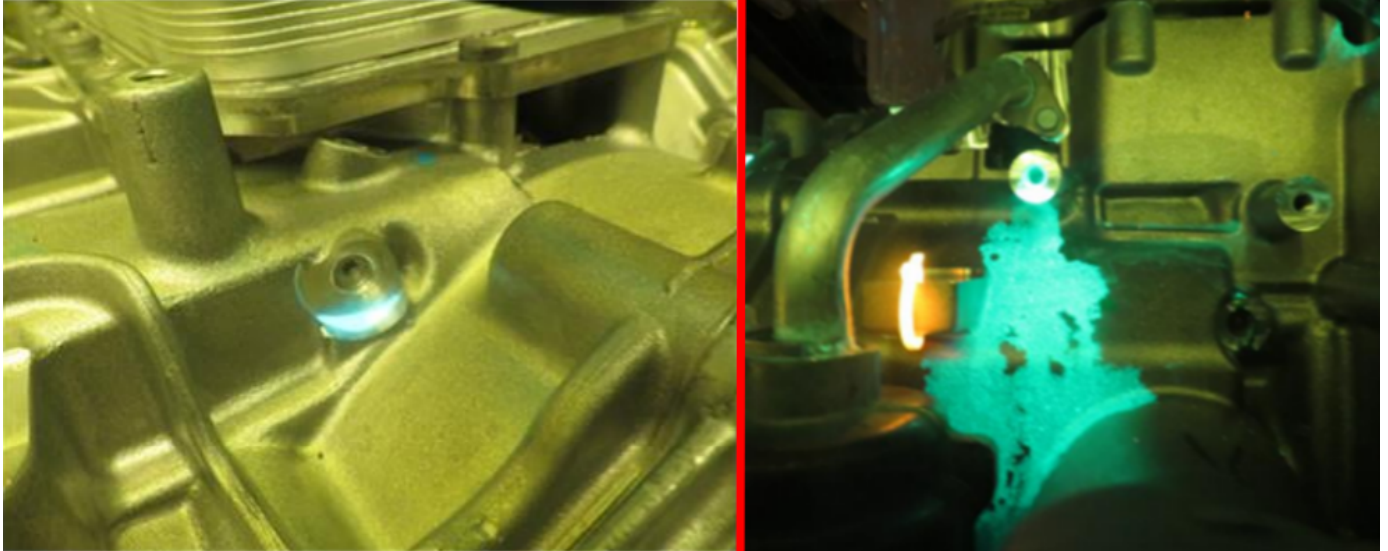

Plug leakage and fluid leaking from blind holes will require transmission replacement.

6636539

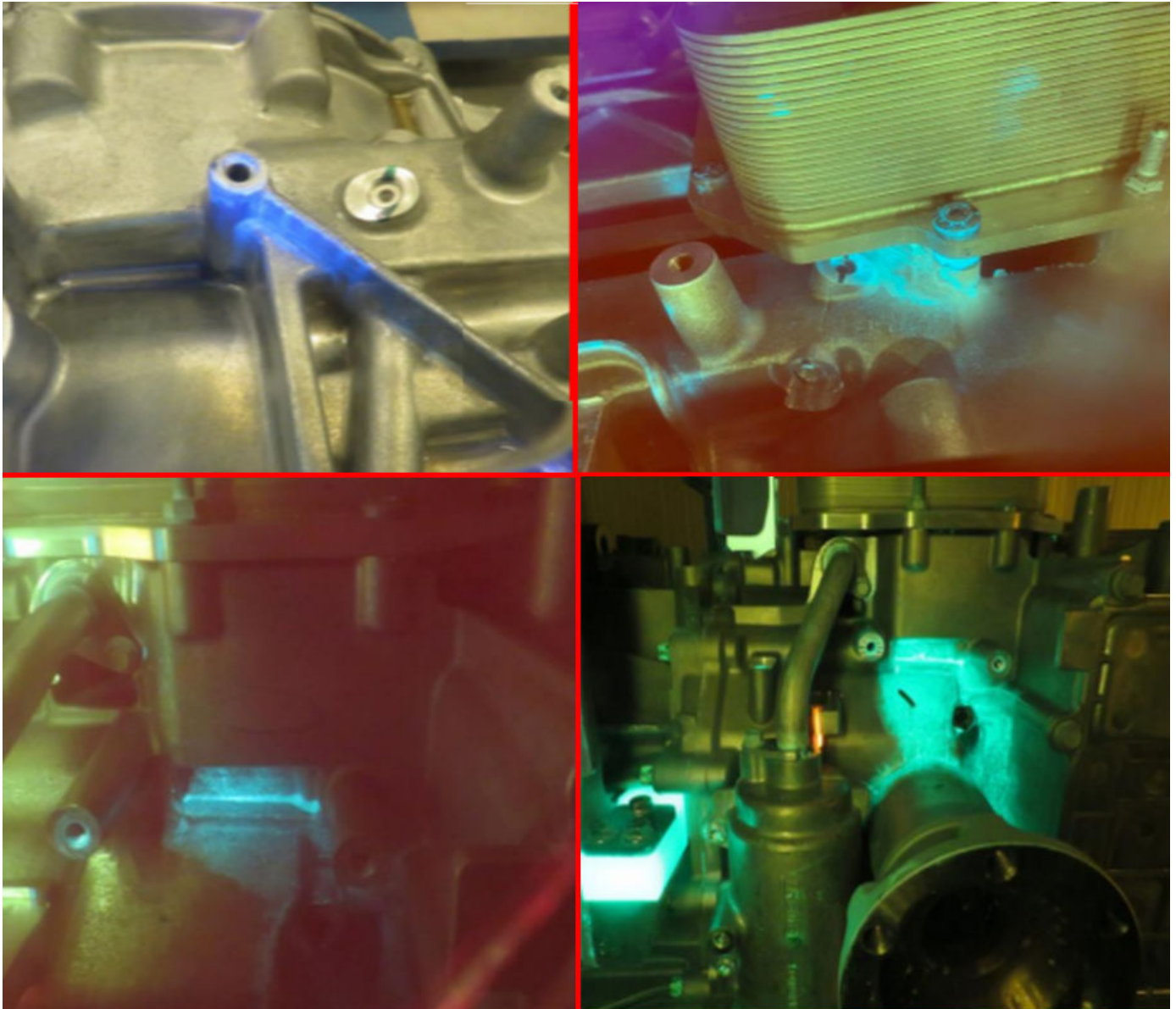

Examples of case porosity in front of the SAV cover and above that left axle stub that may present as an axle seal leak of SAV cover leak. Powder testing should allow identification by the technician. If leak is

porosity in these areas the transmission assembly will need replacement.

6636536



6636545

The graphics represent new areas that may exhibit porosity. The last photos show the difference between rear case porosity and rear cover (Tremec nameplate) leaks.

Important: Keep in mind that adding dye to the DCT transmission is never acceptable. These transmissions had dye added only to highlight the photos. These transmissions were cored after testing. If a technician adds dye to a transmission in the field, it will be necessary to drain and replace all the fluid at a cost to the dealer.

Serviceable components for leaks include:

Clutch Differential Housing Gasket

Input Shaft Seal

Main Shaft Plug

Fluid Tubes and O-rings

MCV (main control valve) Cover and gasket

SAV (solenoid activation valve) Cover and gasket

Canister Filter housing

Canister Filter Cover

Axle Shaft Oil Seals

Cooler and O-rings

Differential Carrier Cover Seal and O-rings (KIT 1)

Rear Cover (Tremec name plate) and O-ring

Version	5
Modified	Released August 24, 2022 Revised June 06, 2023 – Changed Engine and Transmission RPOs to All. Revised October 16, 2023 – Added the 2024 Model Year and Additional Information under Examples of Transmission Leak Areas of Concern section. Revised October 30, 2023 – Added Israel, Japan, Thailand to the Involved Region or Country section and added a Note above the auxiliary canister filter information in the Examples of Transmission Leak Areas of Concern section. Revised May 10, 2024 – Added additional information throughout Examples of Transmission Leak Areas of Concern section and Added New Examples of Transmission Leak Areas of Concern section.

