

MAS004227 RU 24-18

RAPID UPDATE

FROM: Maserati TSO

TO: Maserati Network



Maserati

PERSONAL SERVICE LAB

MASTERS OF CARE

Rapid Update 689

Grecale – RFHM antenna repositioning



ATTENTION! This bulletin supersedes MAS004080 RU 24-11 released on April 23, 2024. Please discard/remove all copies of the previous bulletin.

DATE: MAY 16, 2024

Certain Maserati Grecale (M182) MY23 MY24 listed in MODISCS+ are involved in a Rapid Update to reposition the RFHM antenna.

Under certain conditions, the RFHM system may encounter signal reception issues, resulting in errors and inconveniences for the customer. These may include difficulties in opening doors or the rear hood, despite proximity and the key being readily available.

The procedure utilizes a set of components designed specifically for relocating the RFHM antenna from the original position to a position that improves signal visibility.

We remind you that all the Rapid Updates must be performed within the first workshop visit, regardless of the Mandatory setting set in Modis, as required by Maserati policies.

Also, for vehicles in Stock Dealer / PDI, it is necessary to carry out all action operations before delivery to the end customer, as required by the White Book and explicitly reported in the Pre-delivery checklist.

Please read and review this bulletin first before ordering parts and/or starting the procedure.

Contact your Regional AfterSales Manager (RAM) or the Technical Support Helpdesk if you have any questions.

Thank You for your continued support and cooperation.

Maserati North America
Aftersales Dept.

Overview

The procedure described in this bulletin involves a series of preventive dismantling that must be carried out in conjunction with the procedures outlined in the workshop manual. In this regard, you will find all the components required for rework below, including a relocation template **Included with the bulletin (Grecale_TPMS_bracket_template.pdf)** and the protective materials required, are all listed in the appropriate section of this bulletin.

Additional supplies needed (Not included)

- acrylic polyester tape at least 40 mm wide (See step 62)
- Painter's tape (See step 64)
- anti-corrosion primer (See step 66)

Spare Parts

Parts needed to perform the rework; **it is necessary to order** the following spare parts:

SPARE PARTS	QTY	PN
M182 TPMS ANTENNA RETROFIT BRACKET	670310081	1
SCREW	675001491	2
RIVET (*)	675000323	1
WASHER 6X21	675000441	1
GREEN ANTENNA CABLE	670311391	1
BLUE ANTENNA CABLE	670311392	1

(*) The washer indicated in the table will be available from May 2024. In the meantime, it is possible to use any commercial flat washer suitable for this purpose (**dimensions D.6 – d1 21X1 mm**)

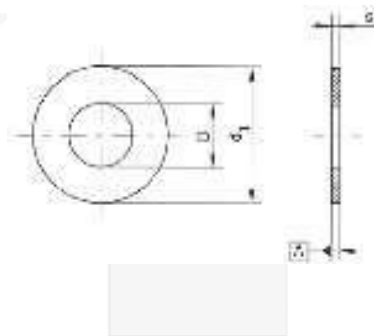

Warranty Claim

Complete the warranty claim as follows:

Description	Code
Rapid Update Number	689
Warranty code	23
Fault code	063
Part Number	8.53.097
Operation Code <ul style="list-style-type: none">▪ Rework	8.53.097. A (2.65 h)

Technical Procedure

 All images shown in this bulletin are for illustrative purposes only

1. Always check ModisCS+ to see if the vehicle is involved in this action and if it has not been previously performed.
2. Considering that the work will take place inside the vehicle, take the necessary precautions to avoid any damage.
3. Before replacing the antenna, disconnect the battery, following the instructions in the workshop manual. **8.20.001 BATTERY Disconnect-Power Supply Connection.**
4. Press the right point first(1) and then the left point (2) without releasing point (1) to release the drive-by-wire transmission panel from the center console.



5. Pull out and remove the drive-by-wire transmission panel from the center console.



6. Disconnect the connector.



7. Remove the screws as shown.



8. Pull out the display as shown.



9. Move the display and disconnect the indicated connector.



10. Release the passenger-side dashboard trim panel (1) with a suitable Teflon tool.



11. Push the passenger-side dashboard trim panel plate with your left hand and release the clip (1) by pulling it downwards as shown.



12. Remove the dashboard clock (1) using a plastic interior trim removal tool.



13. Disconnect the indicated connector and remove the clock on the dashboard



14. Remove the 3 screws shown.

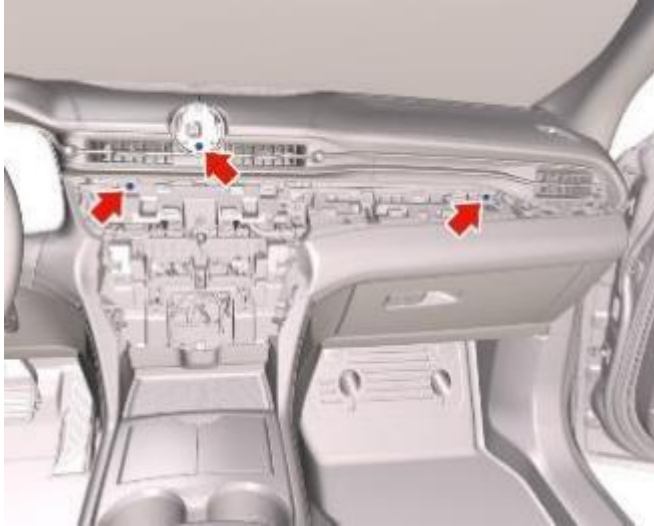

15. Using a plastic interior trim removal tool, remove the central air vent (1)

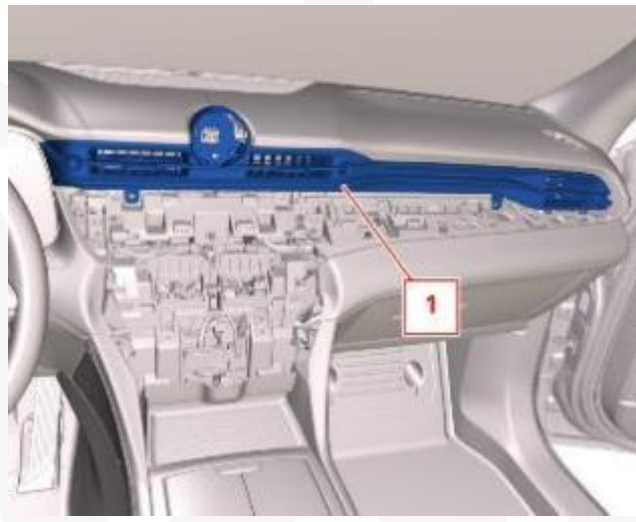

16. Disengage the clips shown.

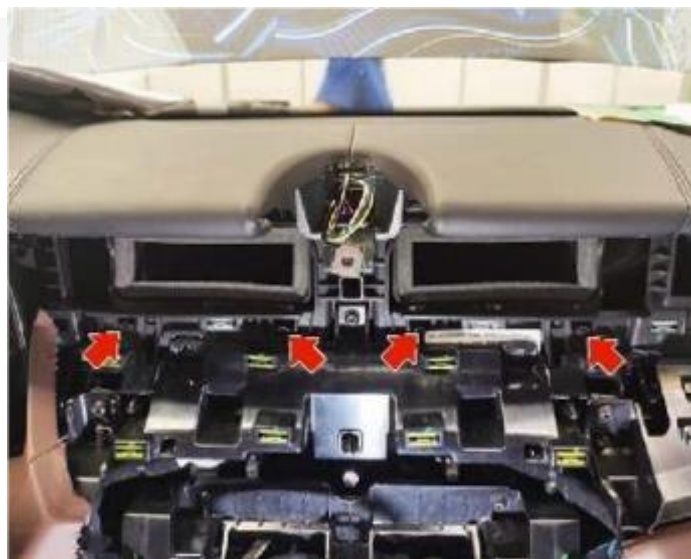

17. Release the clip shown.



18. Release the clip shown.



19. Lower the duct at the left dashboard air opening (1) and the duct at the right dashboard air opening (2) as shown.



20. Pull out the front ceiling light (1) using a plastic interior trim removal tool



21. Disconnect the connector and remove the front ceiling light (1).



22. Release the sun visor (2) from its support (1).

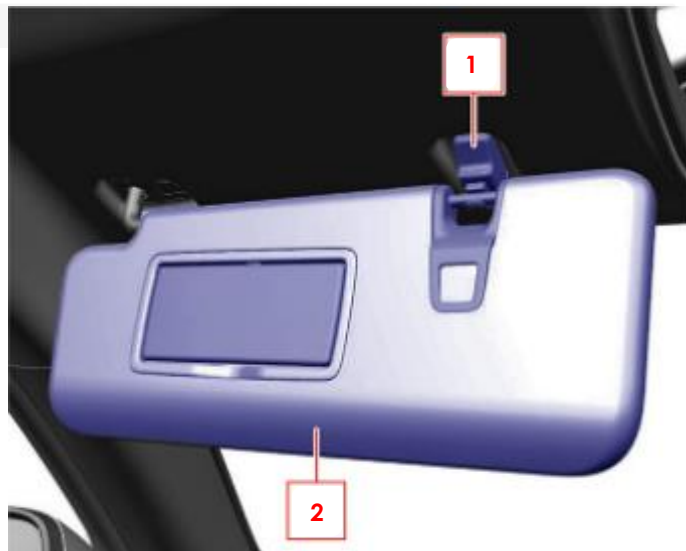

23. Using a plastic interior trim removal tool, remove the sun visor support cover.



24. Undo the screw and remove the sun visor support (1).

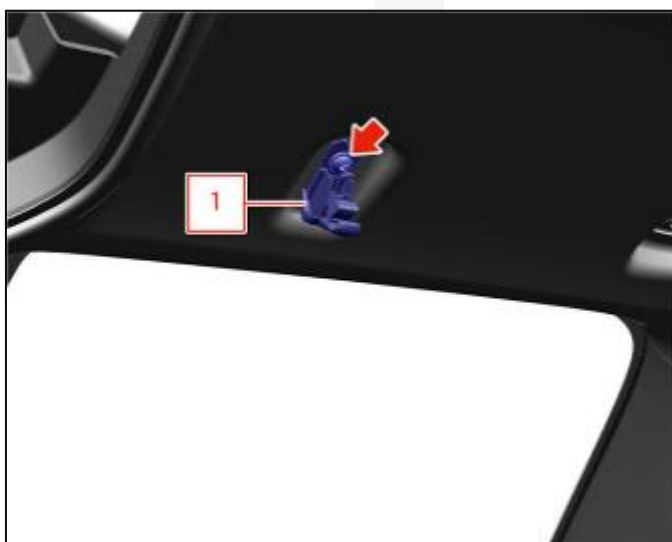

25. Repeat the operation for the passenger-side sun visor support

26. Open the cover (1) and remove the screws shown below.



27. Disconnect the connector and remove the sun visor (1).



- 28. Repeat the procedure for the driver's side sun visor.
- 29. Continue by removing the grab handles
- 30. Open the indicated covers.

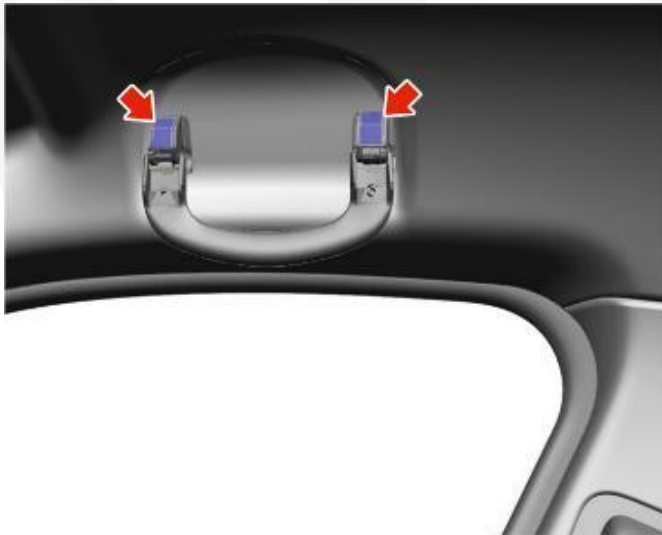

31. Release the indicated clips and remove the right front handle (1).

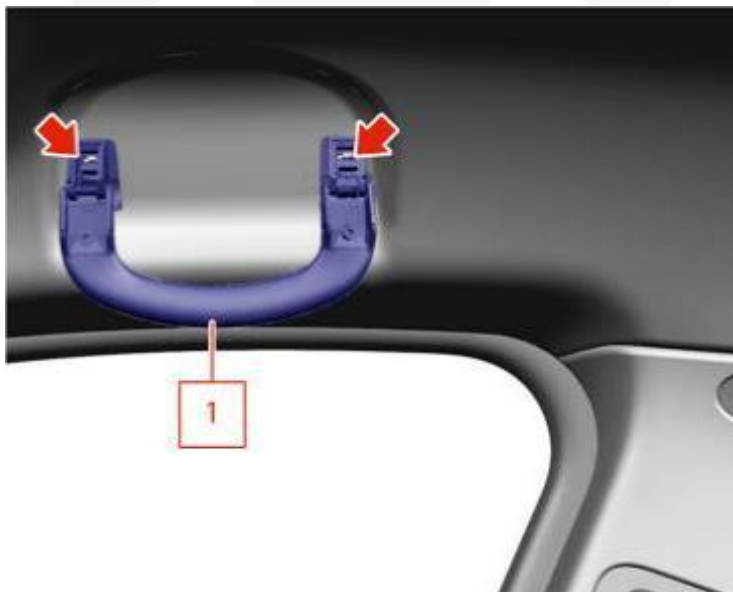

32. Take care to compress the clips at the points indicated to release them, to avoid possible damage.

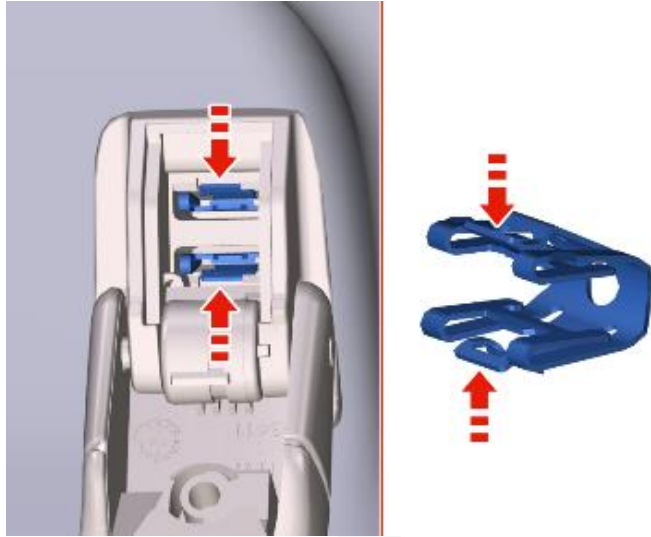

- 33. Repeat the procedure for the front left and rear handles, both right and left.
- 34. Remove the cable trim panel of the interior rear-view mirror (1) using the Teflon tool.
- 35. Remove and open the cover (1) and remove the screw shown below.



36. Carefully disengage and remove the right upper B-pillar cover (1).



37. Repeat the operation for the upper

38. Lower the left rear seat and pull out the trim (1).



39. remove the screws shown



40. Do not remove the lower right C-pillar cover completely



41. Repeat the procedure for the lower left C-pillar cover

Note: Do not remove the lower left C-pillar cover completely



42. Remove the cover (1) and remove the screw shown below.



43. Remove the rear luggage shelf (1).



44. Remove the cover (1) and remove the screw shown below.



45. Using a plastic interior trim removal tool, remove the cover (1).



46. Disconnect the 2 connectors and the seat reclining control cable (1).



47. Remove the rear window pillar cover (1) using a plastic interior trim removal tool.



48. Repeat the procedure on the left rear window pillar cover

49. Using a plastic interior trim removal tool, detach the passenger side dashboard side cover (1), then remove it.



50. Release the upper section of the corner cover of the right side panel (1)



51. Very carefully, detach the right-hand windscreen pillar trim panel (1) from the dashboard (2).



52. Disengage the safety catch (1) and remove the right-hand windscreen pillar cover (1).



53. Repeat the operation for the left windscreen pillar cover

54. Remove the screw shown below.



55. Remove the screw shown below and remove the remote start and input antenna (1).

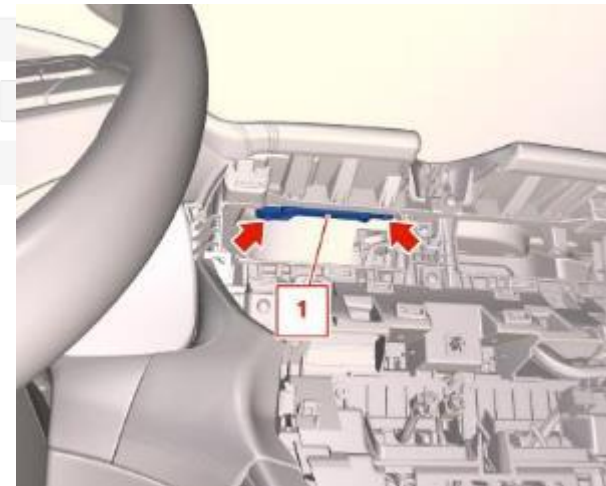

56. At this point, the car is ready for the rework operation and moving the antenna.

57. Disconnect the pink antenna connector and connect the green antenna cable 1 to RFHM. Connect the green antenna cable 1 to RFHM. **Note:** Clips are pre-installed on the wiring harnesses to be used for repair.



58. Plug the green antenna cable into the dashboard and reinstall the RFHM control unit



59. Fix the green antenna cable with cable ties and insert it through the duct, pointing towards the air vent opening on the right.

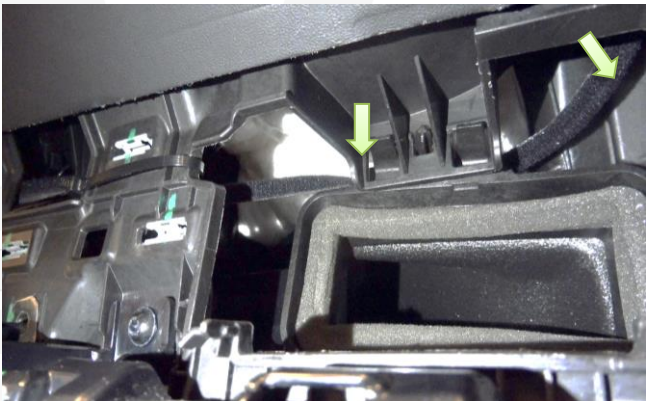

60. Pull the antenna cable through the access indicated by the arrow on the side of the A-pillar, until it exits at dashboard level.

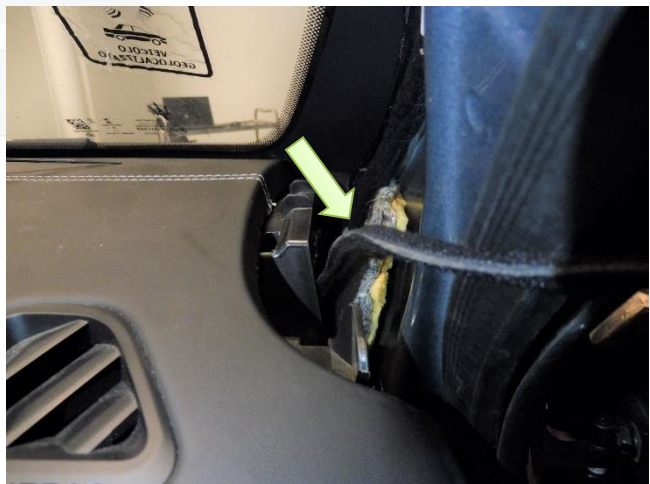

61. Now, going up the pillar, secure the entire green antenna cable with cable ties, as shown in the figure. Leave the end connector disconnected for the moment.



62. At this point, retrieve the "blue" antenna cable and, using an acrylic polyester tape at least 40 mm wide, fasten the cable by following the wiring already present and running along the roof, continuing around the perimeter until it reaches the rear of the roof.

Note: The two connectors, the "green" antenna, and the "blue" antenna must **ONLY** be connected afterward. Therefore, check that they are close but do not connect them at this time.



63. At this point, move the roof panel to clear the area of the rear cross member.

Warning: Make sure that all wiring are disconnected



64. **TPMS ANTENNA RETROFIT BRACKET INSTALL:** To mount and secure the TPMS bracket, it is necessary to drill holes. Use the "TPMS bracket" TEMPLATE included with this bulletin, Position it and secure it as illustrated below using Painter's tape.

 **Use protective eyewear when drilling!**

Protect the interior of the vehicle from metal shaving using a cover!



65. Following the pattern, drill holes in the sheet metal using **5 mm** and **6.5 mm diameter drill bits**, at the positions indicated on the template. **Caution:** Use drill bits with a **maximum length of 50 mm**.

Note: Some vehicles may not need holes to be drilled. The bodywork has already been updated at the Plant. In this case, simply fit the new bracket directly and use the nut **675000324 on the stud present** instead of the rivet. Then continue to follow the instructions from step 68.



66. **AFTER DRILLING THE HOLES:** It is recommended to **treat the perforated area** with the appropriate protective compounds (anti-corrosion primer) before proceeding further.

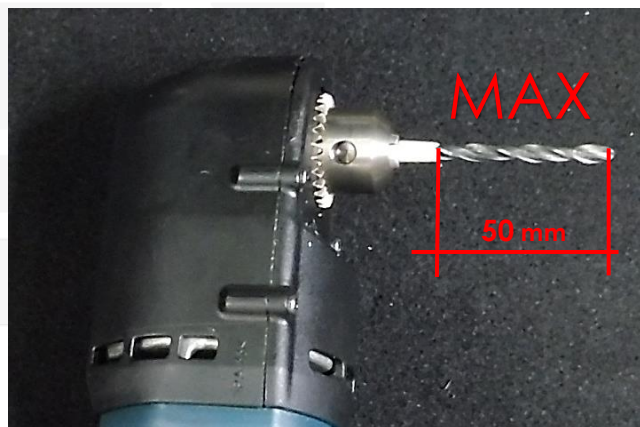

Refer to the instructions in the workshop manual.

▪ **09.AA.008 SEALANT AND CONSUMABLES** in the **ANTICORROSION PROTECTION** section

67. Now, **first**, fit the antenna with the new bracket using the screws and **then** fit the **bracket + antenna** assembly on the car in the previously prepared area.



68. Secure the bracket by inserting the bracket clip into the 6.5 mm hole and use a **rivet with a washer** in the 5-mm hole

Warning: For **RIGHT-HAND DRIVE** cars, fit the **antenna** to the bracket by rotating the component by 180°.



69. Now, connect the antenna connector with the "blue" cable and then the "blue" cable with the "green" cable.



70. To proceed with reassembly, carry out all the following tightening.

71. Tighten the indicated screw to a torque of:

Screw connection	
Tightening cover screw	9 N·m (6.6 ft·lb _f)



Screw connection

Tightening cover screw

9 N·m

(6.6 ft·lb_f)



72. Check the integrity of the clips of each component.

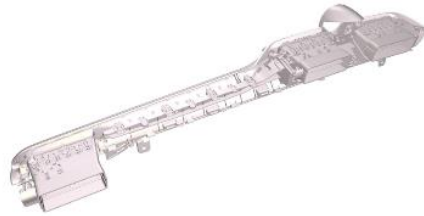

73. Check the condition of the pins.

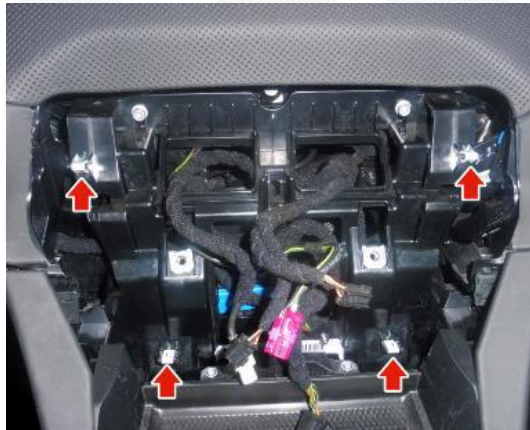

74. Check the fastener before installation



75. Check the fasteners before installation and replace the component if damage is present.

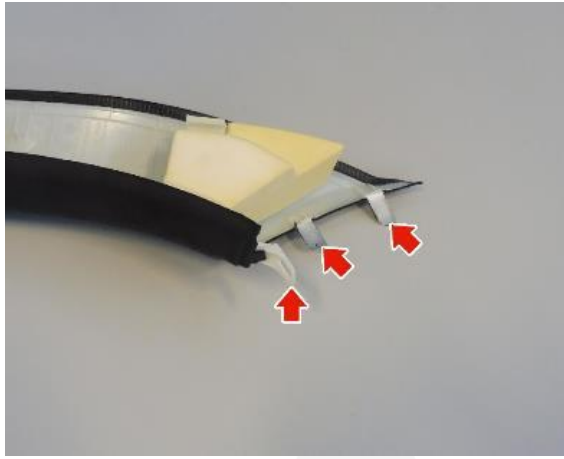

76. Check the indicated safety catch before installation.

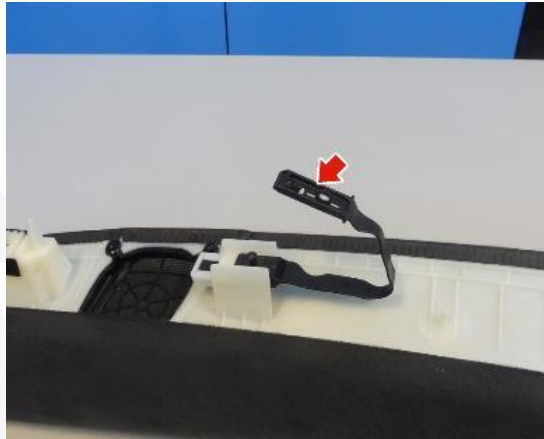

77. Check the integrity of the indicated retainers.

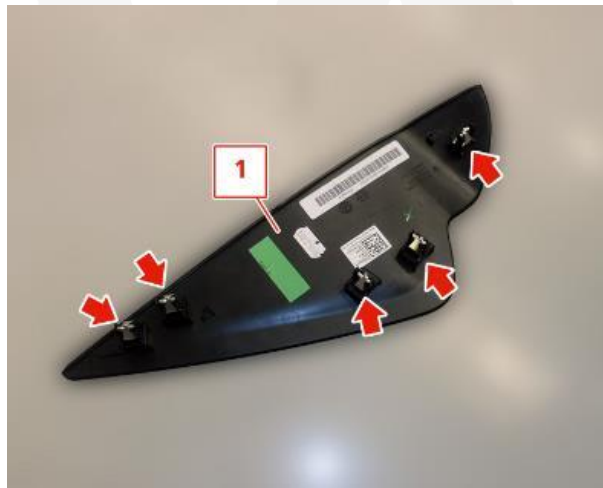

78. Re-install all removed components, following the procedure in reverse order.

79. Procedure complete.