

Subject: RATTLE NOISE FROM RIGHT SIDE OF DASH	Service Alert No.: SA-026/24
	Last Issued : 04/24/2024

BULLETIN NOTES

APPLICABLE MODEL(S)/VINS

2020-2023 CX-30

2019-2023 Mazda3

2023 CX-50

DESCRIPTION

A customer may complain of a rattle noise from the right side of the dash. The noise may be coming from the passenger side airbag.

Customers having this concern should have their vehicle repaired using the following repair procedure.

REPAIR PROCEDURE

Mazda3/CX-30:

1. Perform steps a - d below:
 - a. Remove the cover to access the passenger side airbag.



- b. Loosen the passenger side airbag mounts.

CONSUMER NOTICE: The information and instructions in this bulletin are intended for use by skilled technicians. Mazda technicians utilize the proper tools/ equipment and take training to correctly and safely maintain Mazda vehicles. These instructions should not be performed by "do-it-yourselfers." Customers should not assume this bulletin applies to their vehicle or that their vehicle will develop the described concern. To determine if the information applies, customers should contact their nearest authorized Mazda dealership. Mazda North American Operations reserves the right to alter the specifications and contents of this bulletin without obligation or advance notice. All rights reserved. No part of this bulletin may be reproduced in any form or by any means, electronic or mechanical---including photocopying and recording and the use of any kind of information storage and retrieval system ---without permission in writing.

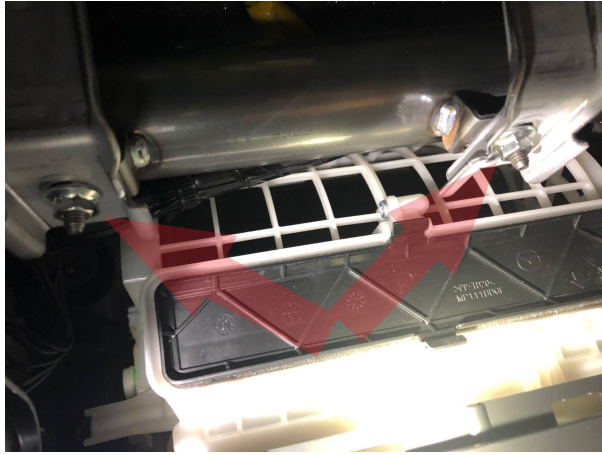

c. Shift the assembly to "center" it.

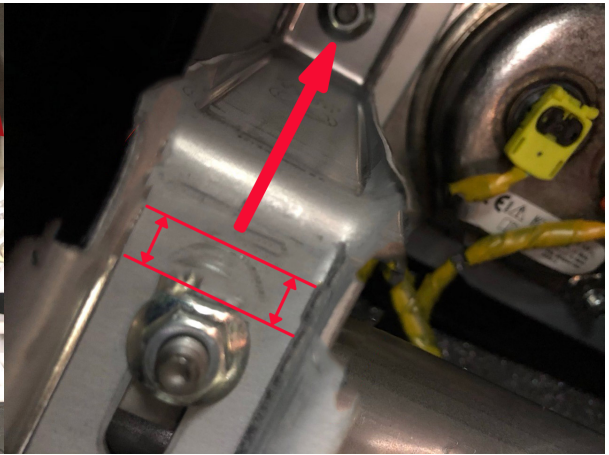
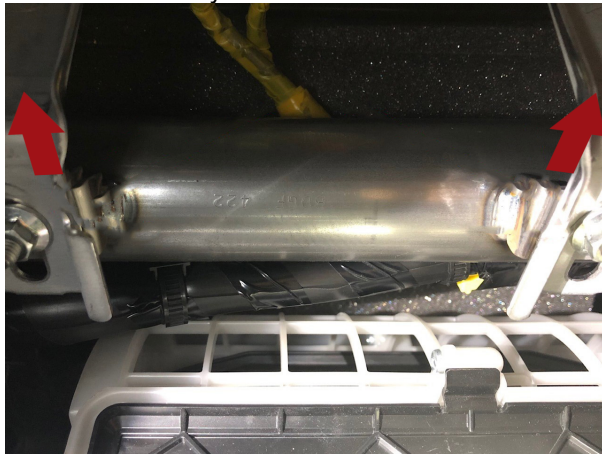

d. Tighten the mounts again to specification while holding the airbag brackets toward the rear of the vehicle.

2. Reassemble the vehicle and confirm the rattle noise has been eliminated.

CX-50:

1. Prepare 4 felt pieces as specified below. Use the Interior Noise Kit (see below) and select the thinnest felt available that is closest to 0.35mm in thickness.

Cut two (2) strips in the dimensions specified below.

Cut one (1) of each of these shapes as specified below.

CONSUMER NOTICE: The information and instructions in this bulletin are intended for use by skilled technicians. Mazda technicians utilize the proper tools/ equipment and take training to correctly and safely maintain Mazda vehicles. These instructions should not be performed by "do-it-yourselfers." Customers should not assume this bulletin applies to their vehicle or that their vehicle will develop the described concern. To determine if the information applies, customers should contact their nearest authorized Mazda dealership. Mazda North American Operations reserves the right to alter the specifications and contents of this bulletin without obligation or advance notice. All rights reserved. No part of this bulletin may be reproduced in any form or by any means, electronic or mechanical---including photocopying and recording and the use of any kind of information storage and retrieval system ---without permission in writing.

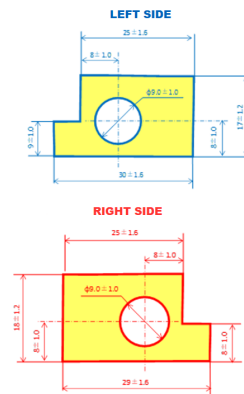
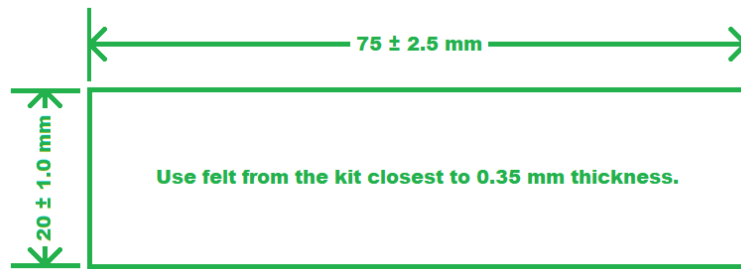

Click the images to enlarge or print them.

- Refer to the **[DASHBOARD REMOVAL]** procedure and follow steps 12 through 16.
NOTE: DO NOT REMOVE THE ENTIRE DASHBOARD.
- Refer to the **PASSENGER-SIDE AIR BAG MODULE REMOVAL/INSTALLATION [TWO-STEP DEPLOYMENT CONTROL SYSTEM - US/CANADA SPEC.]** procedure to lower the airbag. It does not need to be completely removed, but the wiring should be disconnected **to avoid damage to the harness and avoid accidental deployment.**
- The felt tape will be installed in these 4 locations.

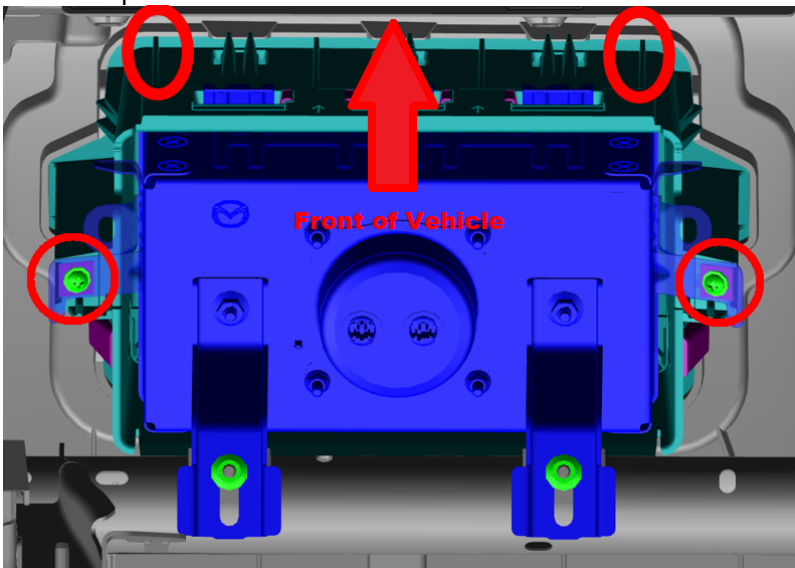

- The felt tape under the bolts should completely cover the clip nuts.

CONSUMER NOTICE: The information and instructions in this bulletin are intended for use by skilled technicians. Mazda technicians utilize the proper tools/ equipment and take training to correctly and safely maintain Mazda vehicles. These instructions should not be performed by "do-it-yourselfers." Customers should not assume this bulletin applies to their vehicle or that their vehicle will develop the described concern. To determine if the information applies, customers should contact their nearest authorized Mazda dealership. Mazda North American Operations reserves the right to alter the specifications and contents of this bulletin without obligation or advance notice. All rights reserved. No part of this bulletin may be reproduced in any form or by any means, electronic or mechanical--including photocopying and recording and the use of any kind of information storage and retrieval system ---without permission in writing.

This area must be completely covered.

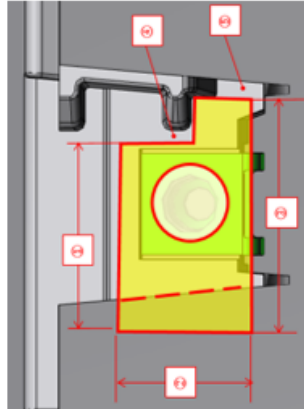

6. The felt tape at the front of the airbag should look like the image below when finished. Remove the backing and tape it as you lift the airbag back into place or cut the strip into 2 pieces and attach them separately. The important point is that when finished, felt-to-felt contact at this location.



7. Reassemble the vehicle and confirm the rattle noise has been eliminated.

CONSUMER NOTICE: The information and instructions in this bulletin are intended for use by skilled technicians. Mazda technicians utilize the proper tools/ equipment and take training to correctly and safely maintain Mazda vehicles. These instructions should not be performed by "do-it-yourselfers." Customers should not assume this bulletin applies to their vehicle or that their vehicle will develop the described concern. To determine if the information applies, customers should contact their nearest authorized Mazda dealership. Mazda North American Operations reserves the right to alter the specifications and contents of this bulletin without obligation or advance notice. All rights reserved. No part of this bulletin may be reproduced in any form or by any means, electronic or mechanical--including photocopying and recording and the use of any kind of information storage and retrieval system ---without permission in writing.

PARTS INFORMATION

Part Number	Description	Qty.	Notes
K001-W0-225	Interior Noise Kit	1	This repairs multiple vehicles, DO NOT claim the kit for one repair.

WARRANTY INFORMATION**NOTE:**

- This warranty information applies only to verified customer complaints on vehicles eligible for warranty repair.
- This repair will be covered under Mazda's New Vehicle Limited Warranty term.
- Additional diagnostic time cannot be claimed for this repair.

Warranty Type	A
Symptom Code	57
Damage Code	9J
Part Number Main Cause	K001-W0-225
Quantity	0
Operation Number / Labor Hours:	S2201BRX / 0.3 Hrs.

NOTE:

- This repairs multiple vehicles, DO NOT claim the kit for one repair.
- The cost of the felt sed is factored into the labor time.

CONSUMER NOTICE: The information and instructions in this bulletin are intended for use by skilled technicians. Mazda technicians utilize the proper tools/ equipment and take training to correctly and safely maintain Mazda vehicles. These instructions should not be performed by "do-it-yourselfers." Customers should not assume this bulletin applies to their vehicle or that their vehicle will develop the described concern. To determine if the information applies, customers should contact their nearest authorized Mazda dealership. Mazda North American Operations reserves the right to alter the specifications and contents of this bulletin without obligation or advance notice. All rights reserved. No part of this bulletin may be reproduced in any form or by any means, electronic or mechanical---including photocopying and recording and the use of any kind of information storage and retrieval system ---without permission in writing.