

# Technical Service Bulletin

Mazda North American Operations  
Irvine, CA 92618-2922



<b>Subject:</b>  FRONT DIFFERENTIAL OIL LEAK FROM OIL SEAL (RH SIDE)	<b>Bulletin No.:</b> 03-001/24
	<b>Last Issued :</b> 04/03/2024

## BULLETIN NOTES

This bulletin supersedes the previously issued bulletin(s) listed below. The changes are noted in Red.

Previous TSBs:	Date(s) Issued:
03-001/24	02/06/24
03-001/23	12/20/23

## APPLICABLE MODEL(S)/VINS

2024 CX-90 with VINS lower than JM3KK\*\*\*\*\*139377 (produced before September 30, 2023)

## DESCRIPTION

Some vehicles may experience differential oil leaking from the oil seal (RH side) at the front differential. This is caused by an inappropriate assembly process of the front differential to the oil pan (vehicle side). To eliminate this concern the front differential assembly process has been changed.

Customers having this concern should have their vehicle repaired using the following repair procedure.

## REPAIR PROCEDURE

1. Verify the customer concern.
  2. Drain the front differential oil [FRONT DIFFERENTIAL OIL REPLACEMENT (AWD)].
  3. Remove the front differential [FRONT DIFFERENTIAL REMOVAL/INSTALLATION (AWD)].
  4. Replace the LH side front oil seal (side gear).
    - a. Remove the front oil seal (side gear) from the front differential carrier using a flathead screwdriver.
- NOTE:** To prevent damaging the inside of the front differential casing, wrap a cloth on the end of the screwdriver.

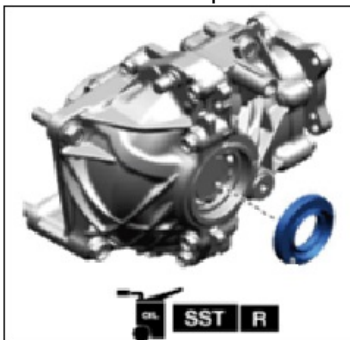

**NOTE:** SST 49T034201A

**CONSUMER NOTICE:** The information and instructions in this bulletin are intended for use by skilled technicians. Mazda technicians utilize the proper tools/ equipment and take training to correctly and safely maintain Mazda vehicles. These instructions should not be performed by "do-it-yourselfers." Customers should not assume this bulletin applies to their vehicle or that their vehicle will develop the described concern. To determine if the information applies, customers should contact their nearest authorized Mazda dealership. Mazda North American Operations reserves the right to alter the specifications and contents of this bulletin without obligation or advance notice. All rights reserved. No part of this bulletin may be reproduced in any form or by any means, electronic or mechanical---including photocopying and recording and the use of any kind of information storage and retrieval system ---without permission in writing.

b. Install the new front oil seal (side gear) using the SST and a hammer

**NOTE:**

- Apply front differential oil to the lip of the new front oil seals (side gear).
- Make sure to install the front oil seals (side gear) straight.

5. Replace the RH (oil pan side) front oil seal (side gear).

a. Remove the front oil seal (side gear) from the front differential carrier using a flathead screwdriver.

**NOTE:** To prevent damaging the inside of the front differential casing, wrap a cloth on the end of the screwdriver.



**NOTE: SST 49T034201A**

b. Install the new front oil seal (side gear) using the SST and a hammer.

**NOTE:**

- Install the front oil seals (side gear) straight.
- **DO NOT** insert the seal until it stops moving. There is a risk of oil leakage due to surface pressure decrease.
- If the SST is not available, the seal can be installed manually by hand. Make sure the seal is installed straight in the bore.

**CONSUMER NOTICE:** The information and instructions in this bulletin are intended for use by skilled technicians. Mazda technicians utilize the proper tools/ equipment and take training to correctly and safely maintain Mazda vehicles. These instructions should not be performed by "do-it-yourselfers." Customers should not assume this bulletin applies to their vehicle or that their vehicle will develop the described concern. To determine if the information applies, customers should contact their nearest authorized Mazda dealership. Mazda North American Operations reserves the right to alter the specifications and contents of this bulletin without obligation or advance notice. All rights reserved. No part of this bulletin may be reproduced in any form or by any means, electronic or mechanical---including photocopying and recording and the use of any kind of information storage and retrieval system ---without permission in writing.

6. Clean any oil residue from oil pan to differential mating surface (blue section).

**NOTE:** If there is dirt or residue of liquid gasket around below hatched area, the differential may leak oil.

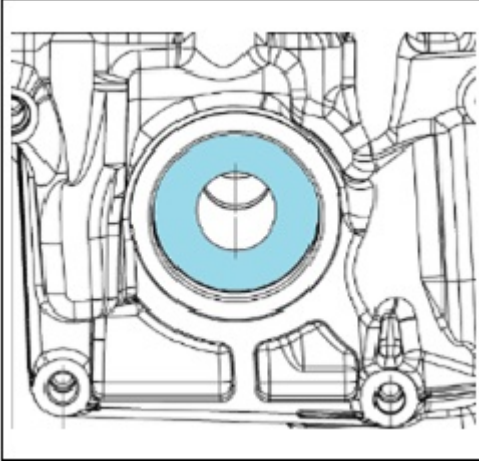

7. Apply a small amount of grease to the engine oil pan surface with the front differential.

**NOTE:**

- Any one of the three options of grease listed below can be used (or an equivalent).
- This procedure is to prevent deformation of the differential oil seal lip during installation.

Brand	Name
Kluber Lubrication	CENTOPLEX 2
Wurth	BRAKE CYLINDER PASTE
Granville	GRANVILLE RED RUBBER GREASE

[How to apply grease to engine oil pan]



- (1) Put small amount of grease on your finger.
- (2) Apply a thin layer of grease all around.

**CONSUMER NOTICE:** The information and instructions in this bulletin are intended for use by skilled technicians. Mazda technicians utilize the proper tools/ equipment and take training to correctly and safely maintain Mazda vehicles. These instructions should not be performed by "do-it-yourselfers." Customers should not assume this bulletin applies to their vehicle or that their vehicle will develop the described concern. To determine if the information applies, customers should contact their nearest authorized Mazda dealership. Mazda North American Operations reserves the right to alter the specifications and contents of this bulletin without obligation or advance notice. All rights reserved. No part of this bulletin may be reproduced in any form or by any means, electronic or mechanical--including photocopying and recording and the use of any kind of information storage and retrieval system ---without permission in writing.

8. Install the front differential to the oil pan as horizontally as possible.

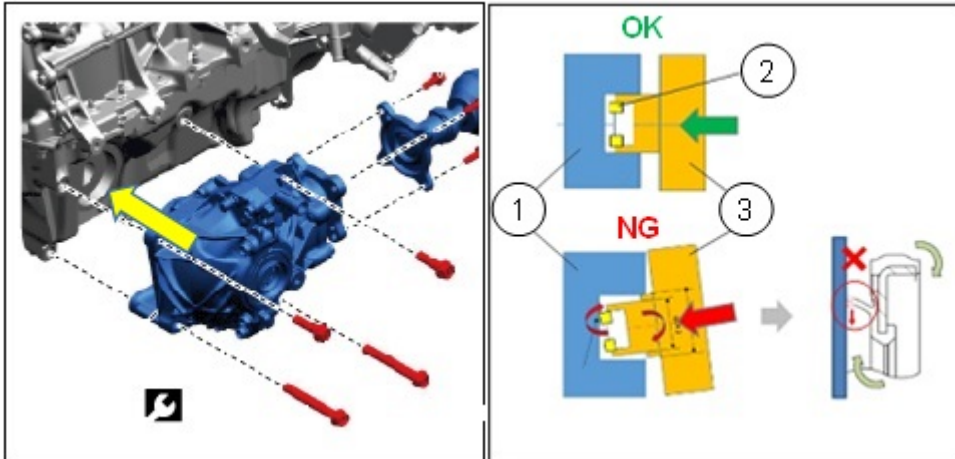

Cross section of oil pan and differential

- (1) Oil pan
- (2) Oil seal
- (3) Differential

9. Install all the parts in reverse order. Refer to [FRONT DIFFERENTIAL REMOVAL/INSTALLATION (AWD)] and [FRONT DRIVE SHAFT REMOVAL/INSTALLATION (AWD)].

10. Verify the repair.

#### PARTS INFORMATION

Parts Number	Description	Qty.	Notes
TAA1-27-397A	Seal, Oil	1	[R]
TAA1-27-238A	Seal, Oil	1	[R]
G003-25-421	Clip	1	[R]
D651-33-042A	Nut	2	[R]
9956-41-800	Washer	2	[R]
T060-26-169A	Pin, Snap	2	[R]

[R]: Replacement parts

**CONSUMER NOTICE:** The information and instructions in this bulletin are intended for use by skilled technicians. Mazda technicians utilize the proper tools/ equipment and take training to correctly and safely maintain Mazda vehicles. These instructions should not be performed by "do-it-yourselfers." Customers should not assume this bulletin applies to their vehicle or that their vehicle will develop the described concern. To determine if the information applies, customers should contact their nearest authorized Mazda dealership. Mazda North American Operations reserves the right to alter the specifications and contents of this bulletin without obligation or advance notice. All rights reserved. No part of this bulletin may be reproduced in any form or by any means, electronic or mechanical---including photocopying and recording and the use of any kind of information storage and retrieval system ---without permission in writing.

**WARRANTY INFORMATION****NOTE:**

- This warranty information applies only to verified customer complaints on vehicles eligible for warranty repair.
- This repair will be covered under Mazda's Powertrain Limited Warranty term.
- Additional diagnostic time cannot be claimed for this repair.

Warranty Type	A
Symptom Code	76
Damage Code	9H
Part Number Main Cause	TAA1-27-397A
Quantity	1
Operation Number / Labor Hours: FCTA: Front Cross Traffic Alert	XXWJTARX / 5.0 Hrs. (PHEV with FCTA) XXWJTBRX / 4.9 Hrs. (PHEV without FCTA) XXWJTARX / 4.9 Hrs (H3T MHEV with FCTA) XXWJTBRX / 4.8 Hrs. (H3T MHEV without FCTA)
	Front wheel alignment check and adjust. A0109LAX / 1.3 Hrs. (Wired type 4-wheel alignment tester) A0109LAX / 0.9 Hrs. (Wireless type 4-wheel alignment tester)

**NOTE:**

- Claim other parts as related parts.
- When the "wheel alignment check & adjustment" is performed at external repair shop, claim the actual invoice amount with the sublet code "C1".
- Warranty policy requires a copy of all sublet invoices be attached to the submitted claim.

**CONSUMER NOTICE:** The information and instructions in this bulletin are intended for use by skilled technicians. Mazda technicians utilize the proper tools/ equipment and take training to correctly and safely maintain Mazda vehicles. These instructions should not be performed by "do-it-yourselfers." Customers should not assume this bulletin applies to their vehicle or that their vehicle will develop the described concern. To determine if the information applies, customers should contact their nearest authorized Mazda dealership. Mazda North American Operations reserves the right to alter the specifications and contents of this bulletin without obligation or advance notice. All rights reserved. No part of this bulletin may be reproduced in any form or by any means, electronic or mechanical--including photocopying and recording and the use of any kind of information storage and retrieval system ---without permission in writing.