

March 2024  
SF681 A-C  
(Revised April 2024)

## **Subject: eCascadia Software Package Update**

**Models Affected: Specific model years 2023-2024 Freightliner eCascadia vehicles, manufactured May 16, 2022, through September 19, 2023.**

### **General Information**

**REVISION:** Work instructions have been revised: Steps 43 & 44 for Groups A & B, Steps 20 & 21 for Group C. Daimler Truck North America LLC (DTNA), on behalf of its Freightliner Trucks division, is initiating Field Service Campaign SF681 A-C to modify the vehicles mentioned above.

Certain eCascadia vehicles require eCPC (Electric Common Powertrain Controller) and BMS (Battery Monitoring System) software updates to resolve multiple issues.

The DCB (Direct Current Box) module(s) will be replaced, and the software will be updated. Vehicles in group A will also receive a coolant plumbing update.

There are approximately 378 vehicles involved in this campaign.

#### **Additional Repairs**

Dealers must complete all outstanding recall and field service campaigns prior to the sale or delivery of a vehicle. A dealer will be liable for any progressive damage that results from its failure to complete campaigns before sale or delivery of a vehicle.

Owners may be liable for any progressive damage that results from failure to complete campaigns within a reasonable time after receiving notification.

Please contact Warranty Campaigns for consideration of additional charges prior to performing the repair.

### **Work Instructions**

Please refer to the attached work instructions. Prior to performing the campaign, check the vehicle for a completion sticker (Form WAR261).

### **Replacement Parts**

Replacement parts are now available and can be obtained by ordering the kit and/or part number(s) listed below from your facing Parts Distribution Center (PDC).

If our records show your dealership has ordered any vehicle(s) involved in campaign number SF681, a list of the customers and vehicle identification numbers will be available in OWL (Online Warranty Link), found on the DTNA Portal. Please refer to this list when ordering parts for this campaign.

March 2024  
SF681 A-C  
(Revised April 2024)

**Table 1** - Replacement Parts for SF681

Campaign Number	Part Number	Part Description	Qty.
SF681 A	66-32674-003	DCB,HV CHRNGNG CNTRL UNT 1,EMG	1
	66-32674-004	DCB,HV CHRNGNG CNTRL UNT 2,EMG	1
	A05-36413-002	PIPE-BATT,BATT1,HOSE	1
	A05-36639-001	PIPE-BATT,BATT-3/2,HOSE	1
	05-37474-000	HOSE BATT-VENT, ID 9.5	1
	05-37580-000	BRKT-BATTERY VENTLINE,LFTNG	1
	05-37579-000	BRKT-BATTERY VENTLINE,PMP ,EP4	1
	23-12691-003	CLAMP-HOSE,CONSTANT TNSN,,375	4
	23-12485-125	CLAMP-WORM,CONSTANT,1-1/4 HOSE	5
	23-14234-001	CLAMP-BEAM,5.5-8.7	3
	23-13476-000	TIE-CLAMP,,5W,15L,4.13BUNDLE	2
	23-14137-001	CABLE TIE-FIR TREE MOUNT,TYC	4
	05-36390-407	FITTING-NORMA,Y CONN,NW7	1
	23-12905-030	SCREW-CAP,HEX,M14X30,10.9 ZNC	1
23-14451-114	NUT-HEX,LKG,VLH,M14X1.5	1	
SF681 B	66-32674-003	DCB,HV CHRNGNG CNTRL UNT 1,EMG	1
	66-32674-004	DCB,HV CHRNGNG CNTRL UNT 2,EMG	1
SF681 C	66-32674-002	DCB,HV CHRNGNG CNTRL UNT 1,EMG	1
ALL GROUPS	WAR261	BLANK COMPLETION STICKER	1

**Table 1**

**Removed Parts**

U.S. and Canadian Dealers, please follow Warranty Failed Parts Tracking shipping instructions for the disposition of all removed parts. Export distributors, please destroy removed parts unless otherwise advised.

**Labor Allowance**

**Table 2** - Labor Allowance

Campaign Number	Procedure	Time Allowed (hours)	SRT Code	Corrective Action
SF681 A	Replace Both Single & Double-Port DCB Modules, Update eCPC & BMS Software, Repair Coolant Pipe Assy	5.8	996-F213A	12-Repair Recall/Campaign
SF681 B	Replace Both Single & Double-Port DCB Modules, Update eCPC & BMS Software	4.3	996-F213B	12-Repair Recall/Campaign
SF681 C	Replace Single-Port DCB Module, Update eCPC & BMS Software	4.2	996-F213C	12-Repair Recall/Campaign

**Table 2**

**IMPORTANT:** When the campaign has been completed, locate the base completion label in the appropriate location on the vehicle, and attach the gray completion sticker provided in the field service kit (Form WAR261). If the vehicle does not have a base completion label, clean a spot on the appropriate location of the vehicle and first attach the base completion label (Form WAR259). If a field service kit is not required or there is no completion sticker in the kit, write the campaign number on a blank sticker and attach it to the base completion label.

March 2024  
SF681 A-C  
(Revised April 2024)

## Claims for Credit

You will be reimbursed for your parts, labor, and handling (landed cost for Export Distributors) by submitting your claim through the warranty system within 30 days of completing this campaign. Please reference the following information in OWL:

- Claim type is **Field Service Campaign**.
- In the Campaign field, enter the campaign number and appropriate group (**SF681-A, SF681-B, etc.**).
- In the Primary Failed Part field, enter **25-SF681-000**.
- In the Parts section, enter the appropriate part number(s) as shown in the Replacement Parts Table.
- In the Labor section, enter the appropriate SRT from the Labor Allowance Table. Administrative time will be included automatically as SRT 939-6010A for 0.3 hours.
- The VMRS Component Code is **F99-999-005** and the Cause Code is **A1 - Campaign**.
- This Field Service Campaign will **terminate on March 31, 2025**. Dealers will be notified of any changes to the termination date via an Important Campaign Information Letter (ICI) posted on the DTNA Portal.

**IMPORTANT:** OWL must be viewed prior to beginning work to ensure the vehicle is involved and the campaign has not previously been completed. Check for a completion sticker before beginning work.

All claims must be submitted within 30 days of the repair and within 30 days of the termination date of the campaign. U.S. and Canadian Dealers: All excess inventory to be returned to the PDC following the conclusion of the campaign must be returned in resaleable condition to the Memphis PDC within 90 days from the termination date. Please submit a PAR to request return to the Memphis PDC. (Canadian dealers should return the kits to their facing PDC.) Export Distributors: Excess inventory is not returnable.

For questions, U.S. and Canadian dealers, contact the Warranty Campaigns Department using the Warranty Support Center (WSC) app located on the DTNA Portal. Export distributors, submit a WSC inquiry, or contact your International Service Manager.

March 2024  
SF681 A-C

## Copy of Notice to Owners

### Subject: eCascadia Software Package Update

Daimler Truck North America LLC (DTNA), on behalf of its Freightliner Trucks division, is initiating Field Service Campaign SF681 A-C to modify specific model years 2023-2024 Freightliner eCascadia vehicles, manufactured May 16, 2022, through September 19, 2023.

Certain eCascadia vehicles require eCPC (Electric Common Powertrain Controller) and BMS (Battery Monitoring System) software updates to resolve multiple issues.

The DCB (Direct Current Box) module(s) will be replaced, and the software will be updated. Vehicles in group A will also receive a coolant plumbing update.

Please contact an authorized DTNA dealer to arrange to have the campaign performed and to ensure that parts are available at the dealership. The campaign will take approximately four to six hours and will be performed **free of charge**. To locate an authorized dealer, search online at [northamerica.daimlertruck.com/contact-us](http://northamerica.daimlertruck.com/contact-us). Scroll down to "Locate a Dealer," and select the appropriate brand.

This Field Service Campaign will **terminate on March 31, 2025**. Please make sure the campaign is completed prior to this date. Work completed after this date will be done at the customer's expense.

As stated in the terms of your express limited warranty, DTNA will not pay for any damage caused by failure to properly maintain your vehicle. DTNA considers the work necessary under this campaign to be proper maintenance and will, therefore, not pay for any damage to your vehicle caused by your failure to have the repairs that are the subject of this campaign performed in a reasonable time.

Contact the Warranty Campaigns Department at (800) 547-0712, from 7 a.m. to 4 p.m. Pacific Time, Monday through Friday, e-mail address [dtna-war-campaigns@daimlertruck.com](mailto:dtna-war-campaigns@daimlertruck.com), or the Customer Assistance Center at (800) 385-4357, if you have any questions or need additional information.

WARRANTY CAMPAIGNS DEPARTMENT

Enclosure

March 2024  
SF681 A-C  
(Revised April 2024)

## Work Instructions

### Subject: eCascadia Software Package Update

**Models Affected:** Specific model years 2023-2024 Freightliner eCascadia vehicles, manufactured May 16, 2022, through September 19, 2023.

**REVISION:** Work instructions have been revised: Steps 43 & 44 for Groups A & B, Steps 20 & 21 for Group C.

### SF681 A: Replacement of Direct Current Box (DCB) Modules & Coolant Plumbing Update

1. Check the base label (Form WAR259) for a completion sticker for SF681 (Form WAR261), indicating this work has been done. The base label is usually located on the passenger-side door, about 12 inches (30 cm) below the door latch. If a completion sticker is present, no work is needed. If a completion sticker is not present, proceed to the next step.
2. Park the vehicle on a level surface, place the vehicle in neutral, shut down the vehicle, and set the parking brake. Chock the tires.

### DANGER

Service and repair of the electric vehicle should only be performed by technicians that have completed HV2 or HV3 Daimler Safety Training. Decommissioning and commissioning of the HV system should only be performed by technicians that have completed HV3 Daimler Safety training. To prevent personal injury or death, or damage to the electric system, do not attempt repairs yourself.

Decommission the vehicle and verify the high voltage system is shut down. Failure to follow these steps could result in serious personal injury or death.

3. Decommission the vehicle. For instructions, see **Section 08.08** of the *eCascadia Workshop Manual*.

March 2024  
SF681 A-C  
(Revised April 2024)

4. Remove the left-hand side battery deck plate. See **Fig. 1**. For instructions, see **Section 31.05** of the *eCascadia Workshop Manual*.
5. Remove the left-hand side battery protection cover that is attached to the side impact protection assembly. See **Fig. 1**.

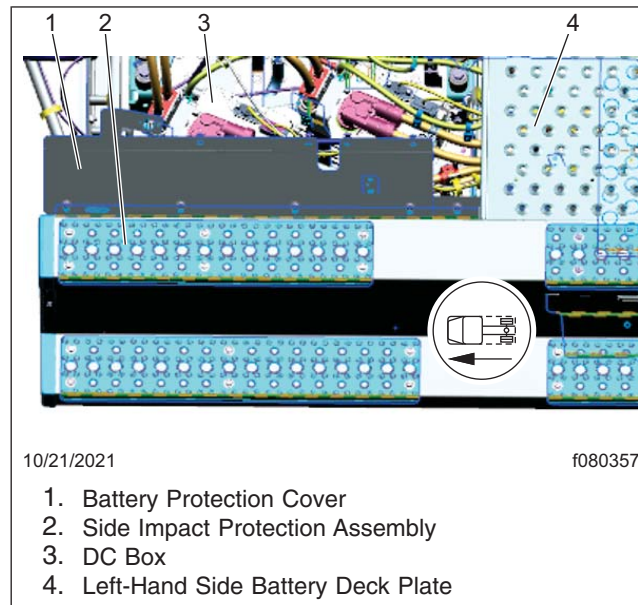

**Fig. 1, Removal of Battery Protection Cover**

6. Remove the side impact protection. For instructions, see **Section 31.03, Subject 100** of the *eCascadia Workshop Manual*.
7. Drain the battery cooling circuit.
8. Remove the high voltage cable clamps.

**IMPORTANT:** High-voltage connectors need to be kept clean and clear of debris, fluids, and damage. A dirty or damaged connector can cause problems for energy transfer within the cable or high voltage components and can lead to high voltage system failures.

**NOTE:** To ensure the high voltage connectors are installed vertically during installation, use the tool (DSNEMG022008) to connect the three high voltage connectors.

9. Remove the high voltage connectors from the DC boxes.
10. Remove the fasteners from the ground cables, then disconnect the ground cables.
11. Disconnect the low voltage cable connectors from the DC boxes and the front side of the ground bracket.
12. Gently move the high voltage, low voltage, and ground cables out of the way.
13. Transfer the high voltage connector protective caps from the new DC boxes to the high voltage connections on the DC boxes being removed.
14. Disconnect the coolant lines from the DC boxes.

March 2024  
SF681 A-C  
(Revised April 2024)

15. Remove the DC box mounting bracket fasteners. See [Fig. 2](#).

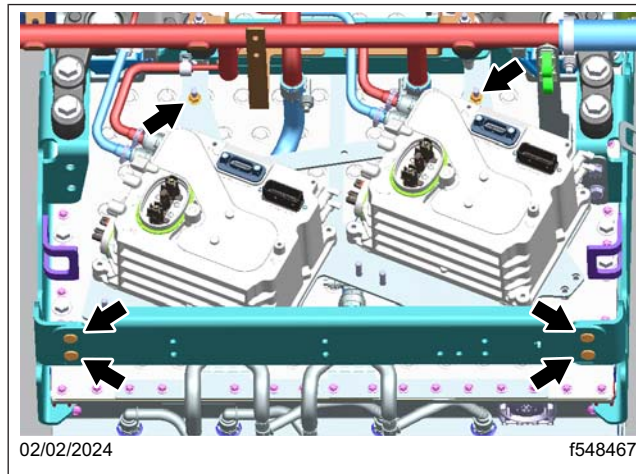

**Fig. 2, DC Box Mounting Bracket Fasteners**

16. Remove the DC boxes and bracket from the vehicle.

17. Remove the DC boxes from the mounting bracket. See [Fig. 3](#).

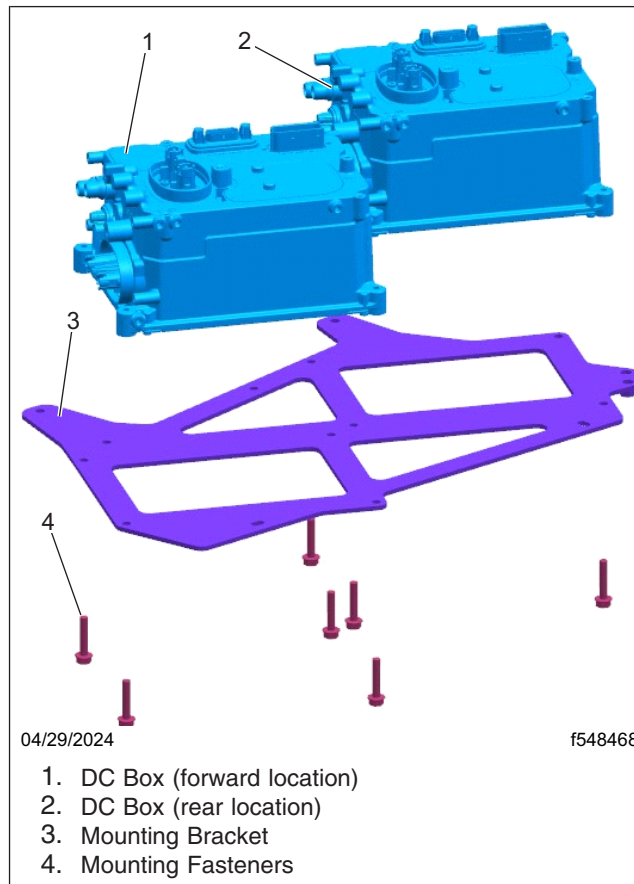

**Fig. 3, Removal of DC Boxes**

March 2024  
SF681 A-C  
(Revised April 2024)

18. Remove the ground cable support bracket from the front high voltage battery B1 mounting bracket, then remove the coolant pipe. See [Fig. 4](#).

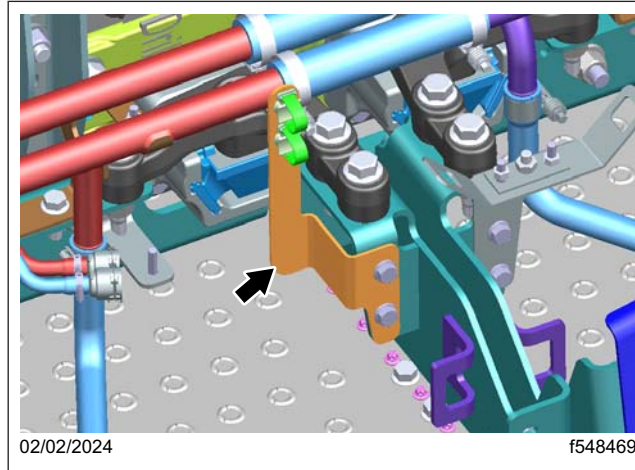

**Fig. 4, Ground Cable Support Bracket**

19. Remove the hardline from over the high voltage battery B1. See [Fig. 5](#).

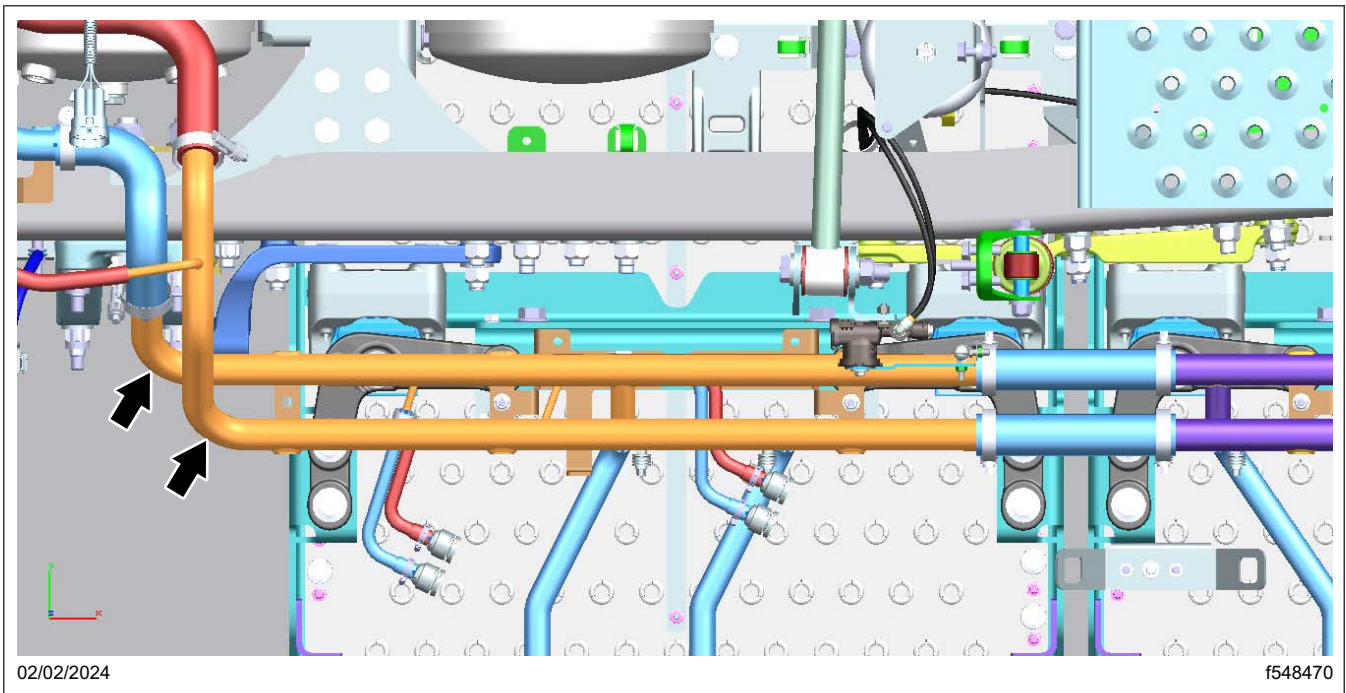

**Fig. 5, Hardline over the High Voltage Battery B1**

20. Disconnect the frontbox ground cables See [Fig. 6](#), on the next page.
21. Disconnect the main low voltage harness from the frontbox. Disconnect the LV harness from the coolant pump. See [Fig. 6](#).
22. Remove the high voltage cable clamps in the hardline area, and gently move the high voltage cables out of the way. See [Fig. 6](#).

March 2024  
SF681 A-C  
(Revised April 2024)

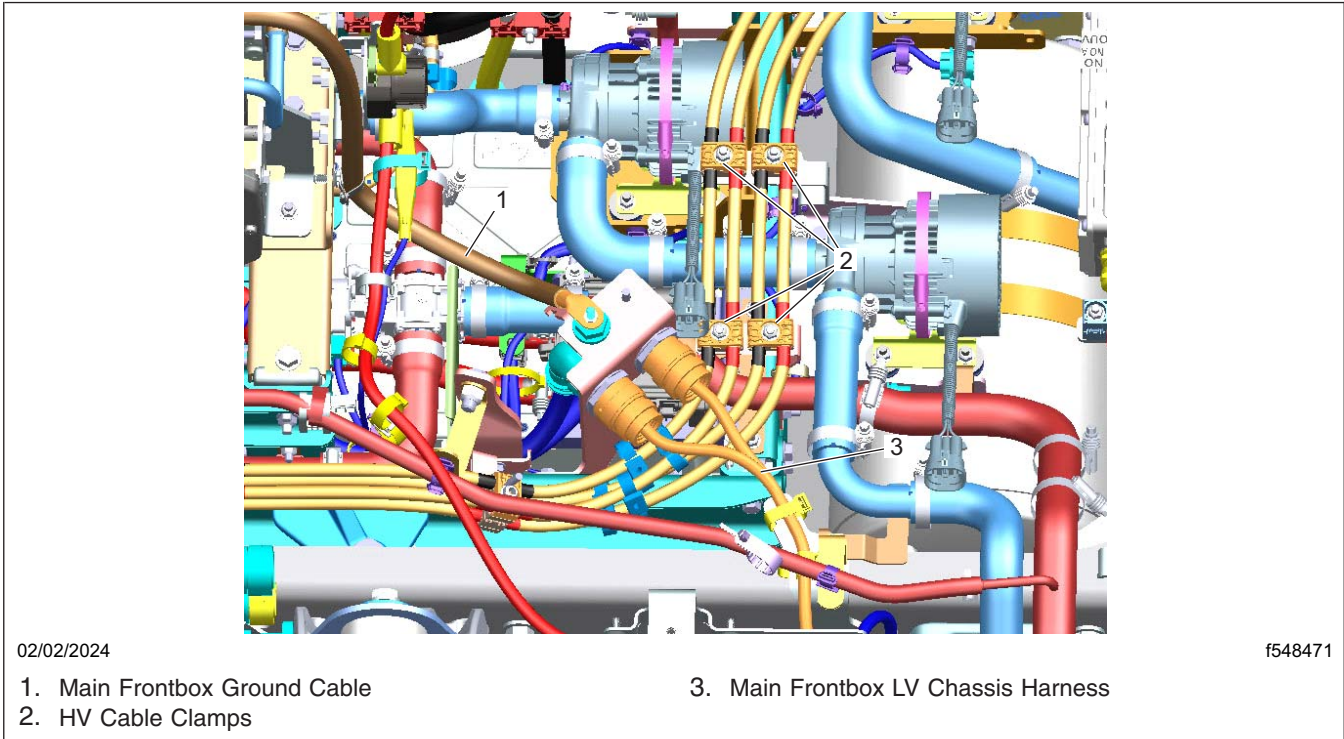

**Fig. 6, Frontbox Wiring Harness Connections**

23. Remove the mounting fasteners that attach the hardline to the pump, then disconnect the hardline from the pump. See **Fig. 7**.

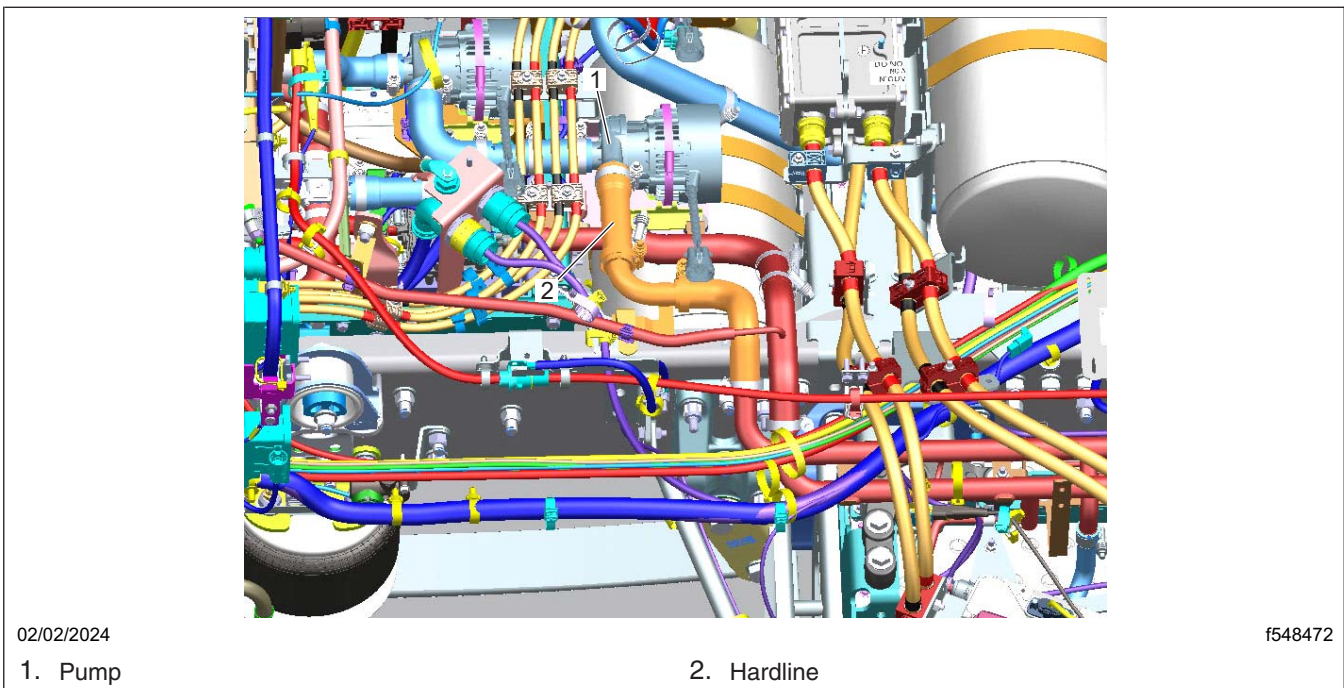

**Fig. 7, Disconnecting Hardline from Pump**

March 2024  
SF681 A-C  
(Revised April 2024)

24. Remove the mounting fasteners that attach the hardline to the 3/2 valve, then disconnect the hardline from the 3/2 valve. See [Fig. 8](#).

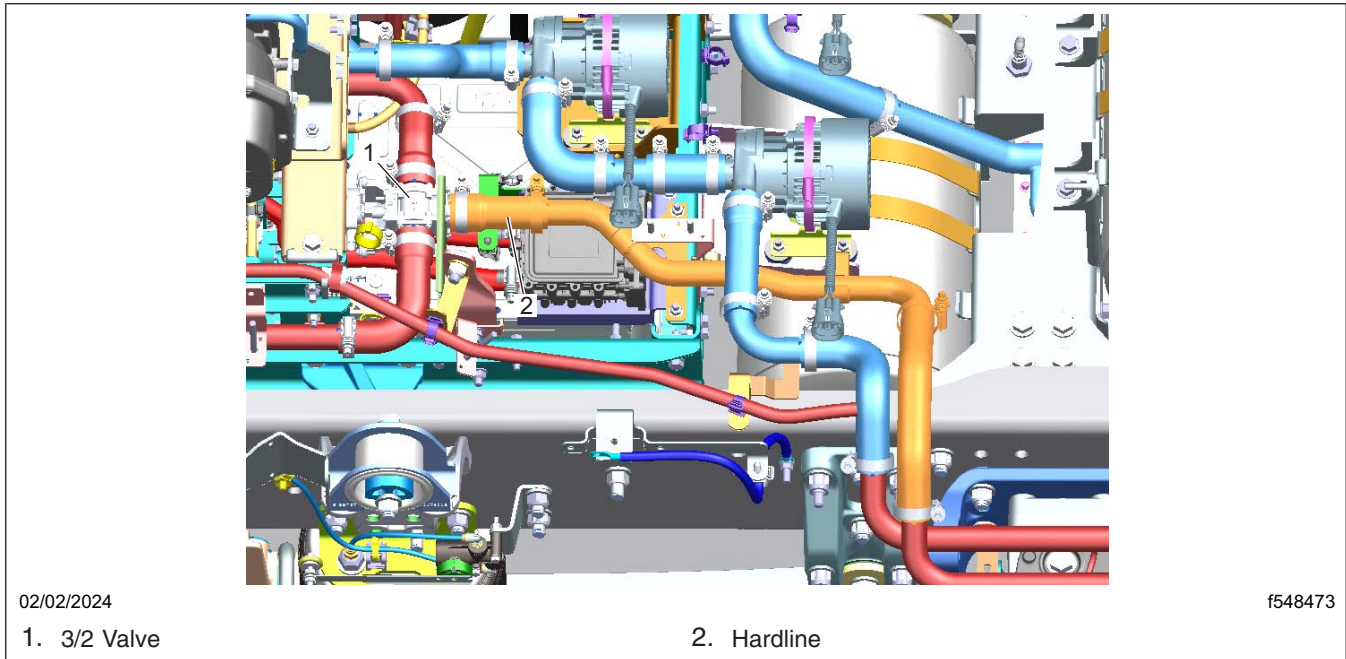
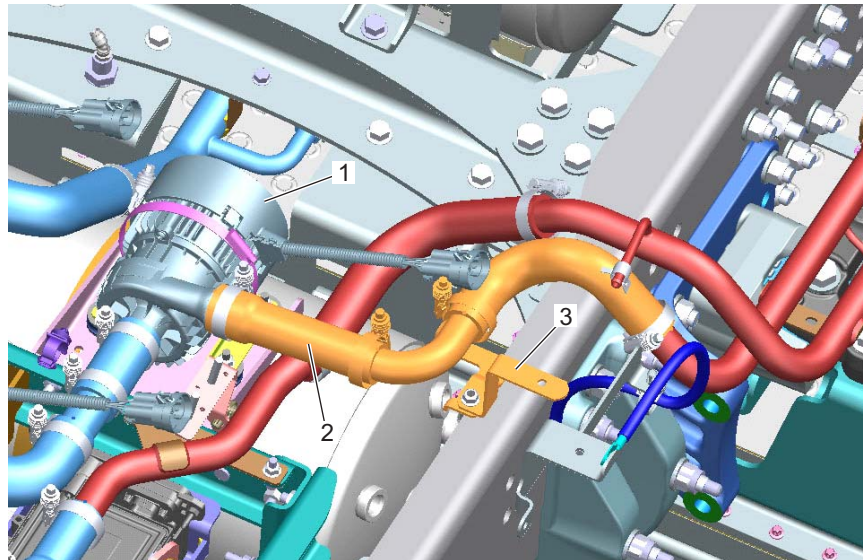

**Fig. 8, Disconnecting Hardline from 3/2 Valve**

25. Install the hardline on the 3/2 valve, and install the mounting fasteners.  
26. Install the hardline on the pump.

March 2024  
SF681 A-C  
(Revised April 2024)

27. Install the vent bracket, and install the mounting fasteners. See [Fig. 9](#).



02/02/2024

f548474

1. Pump

2. Hardline

3. Vent Bracket

**Fig. 9, Connecting Hardline to Pump**

28. Gently move the high voltage cables back to their original position, then install the high voltage cable clamps.
29. Connect the low voltage chassis harness to the main frontbox.
30. Connect the wiring harness to the coolant pump.
31. Connect the ground cables to the main frontbox, and tighten 115 lbf-in (1300 N-cm).
32. Install the hardline over the high voltage battery B1.
33. Tighten all coolant line connections 62 lbf-in (700 N-cm).

March 2024  
SF681 A-C  
(Revised April 2024)

34. Install the vent line bracket, and install the mounting fastener. See **Fig. 10**.

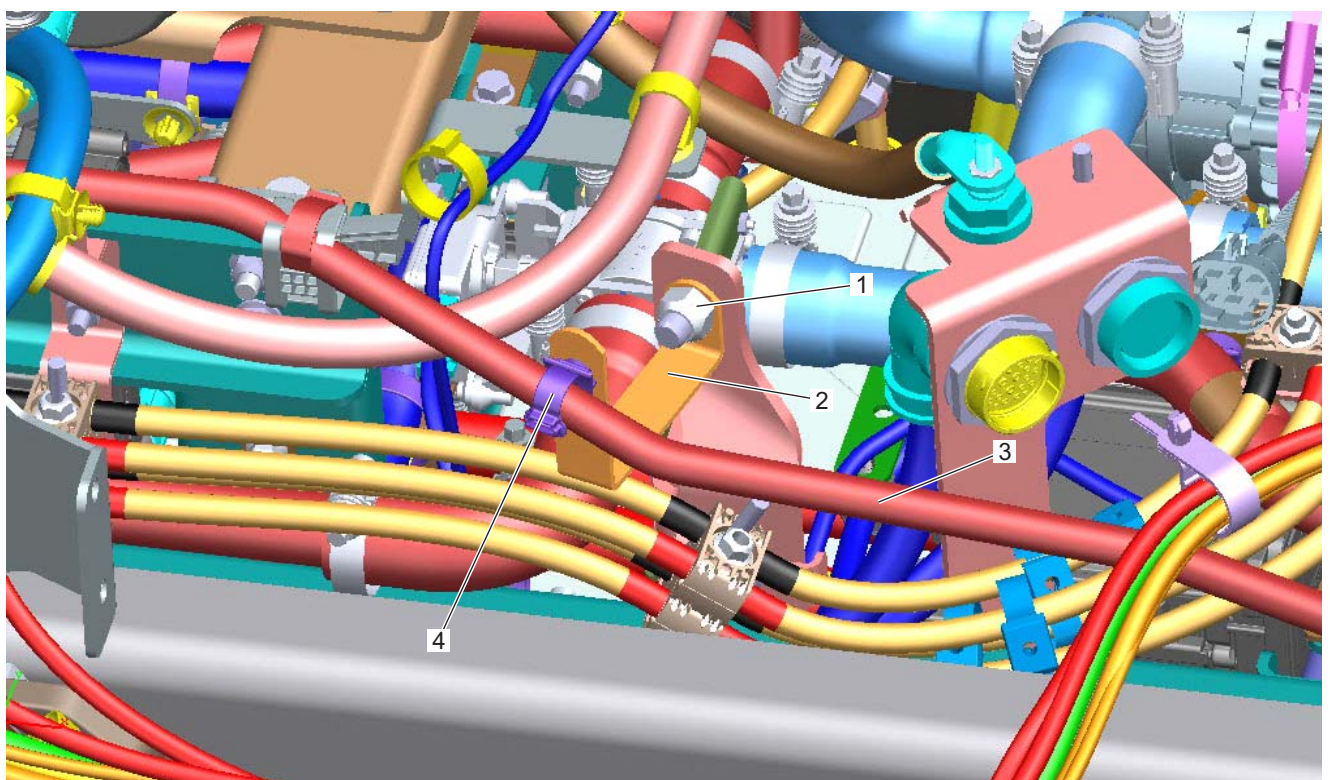

02/09/2024

f548486

1. Mounting Fastener  
2. Vent Line Bracket

3. Vent Hose  
4. Cable Tie

**Fig. 10, Installation of Vent Line Bracket**

35. Remove the left-hand side radiator support and fasteners to get access to cut the vent line. See **Fig. 11**.

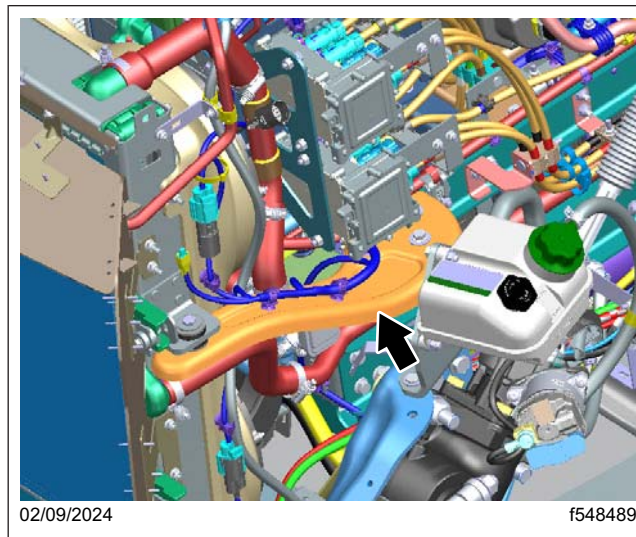

02/09/2024

f548489

**Fig. 11, Left-Hand Side Radiator Support**

March 2024  
SF681 A-C  
(Revised April 2024)

36. Cut the front portion of the vent line hose, and install the Y-fitting. See [Fig. 12](#) and [Fig. 13](#).

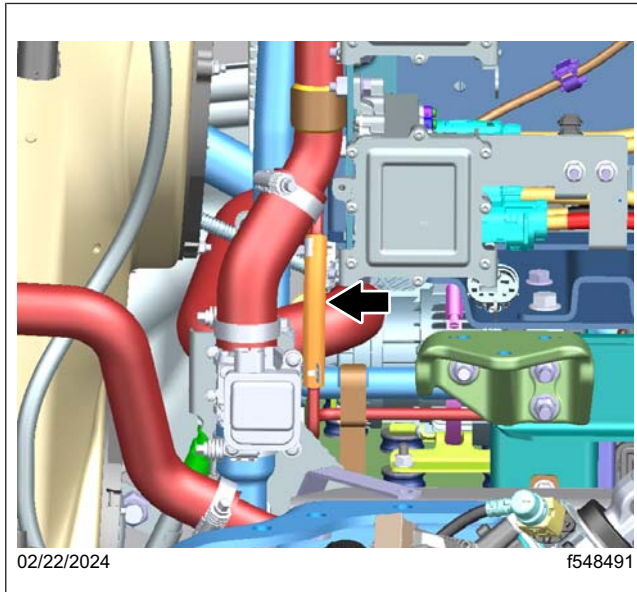

**Fig. 12, Vent Line to Cut**

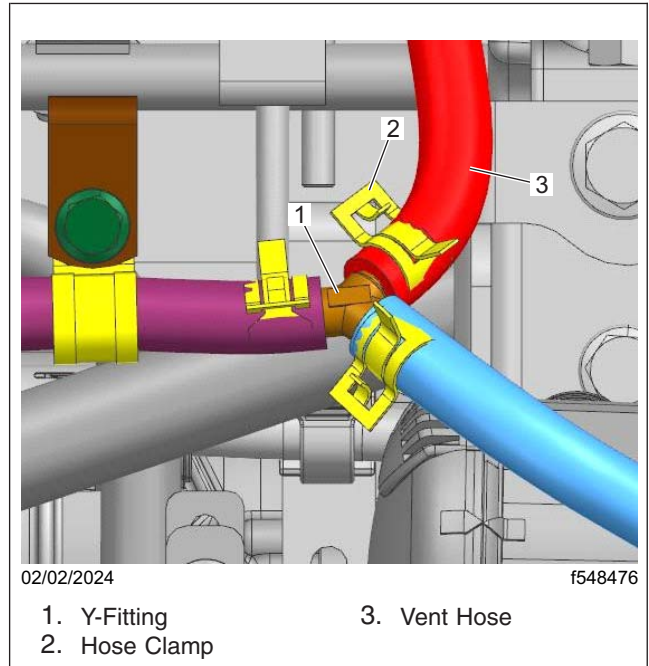

**Fig. 13, Y-Fitting**

March 2024  
SF681 A-C  
(Revised April 2024)

37. Install and route the vent line. See [Fig. 14](#).
38. Install the frame clamps, and secure the vent line with a cable tie. See [Fig. 14](#) and [Fig. 15](#).

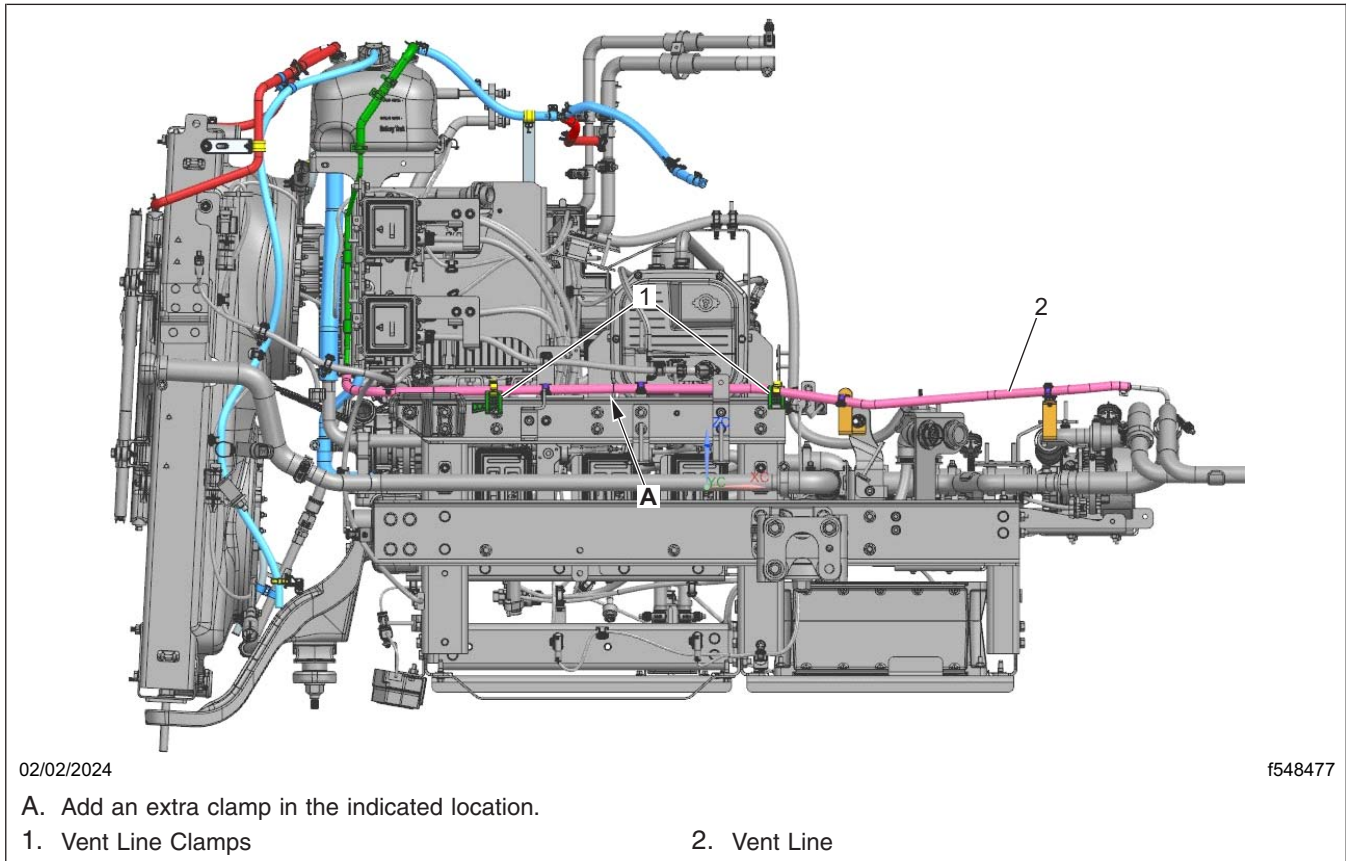

**Fig. 14, Vent Line Routing**

March 2024  
SF681 A-C  
(Revised April 2024)

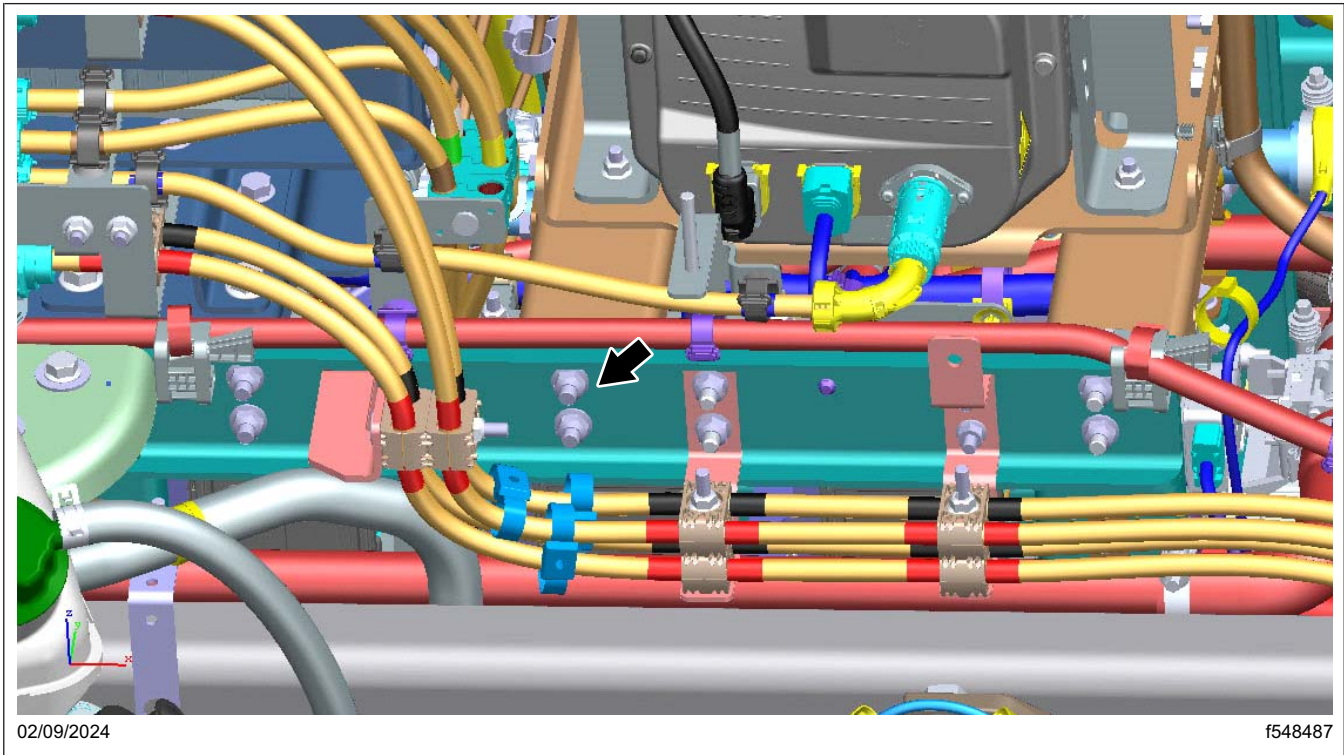

**Fig. 15, Location of Frame Clamp**

39. Install the left-hand side radiator support and fasteners. Tighten the three rear fasteners 35 lbf·ft (48 N·m) and the front isolated fastener 59 lbf·ft (80 N·m).
40. Clean any spilled coolant from the top of the battery.
41. Install the ground cable support bracket.
42. Transfer the high voltage connector protective caps from the old DC boxes to the new DC boxes.
43. Install the DC boxes on the mounting bracket, and install the fasteners that attach the DC boxes to the mounting bracket. Tighten the fasteners 115 lbf·in (1300 N·cm). See [Fig. 3](#).

**IMPORTANT:** Install the DC box high voltage charging control unit 1 (66-32674-003) in the forward location, and the DC box high voltage charging control unit 2 (66-32674-004) in the rear location.

44. Install the DC boxes and bracket on the vehicle. See [Fig. 2](#).
45. Install and tighten the mounting bracket fasteners.
46. Connect the coolant lines to the DC boxes.
47. Route the wiring harnesses back to the original positions.
48. Connect the low voltage connectors to the DC boxes and on the front side of the ground bracket.
49. Install the ground cable fasteners. Tighten the smaller nut and the DC box bolt 11 lbf·ft (15 N·m), and the larger nut 35 lbf·ft (48 N·m).

March 2024  
SF681 A-C  
(Revised April 2024)

**IMPORTANT:** Clean any dirt or debris from high voltage connectors before removing them. Failure to do so could increase the chance of dirt getting into the connector during installation.

50. To ensure the high voltage connectors are installed vertically during installation, use the tool (DSNEMG022008) to connect the three high voltage connectors.
51. Remove the alignment pin, and install the high voltage connector mounting fasteners.
52. Install the high voltage cable clamps, and tighten the fasteners.
53. Tighten the high voltage connector fasteners 14 lbf·ft (19 N·m).
54. Secure the low voltage harnesses and the ground cables with cable ties.
55. Install the side impact protection. For instructions, see **Section 31.03, Subject 100** of the *eCascadia Workshop Manual*.
56. Remove the block off plate of the dual port charger. See **Fig. 16**.



**Fig. 16, Location of the Block Off Plate**

57. Install the forward battery cover that is attached to the side impact protection assembly.
58. Install the left-hand side battery deck plate. For instructions, see **Section 31.05** of the *eCascadia Workshop Manual*.
59. Commission the vehicle. For instructions, see **Section 08.08** of the *eCascadia Workshop Manual*.
60. Fill and bleed the battery cooling system. For instructions, see **Section 20.01, Subject 160** of the *eCascadia Workshop Manual*.

March 2024  
SF681 A-C  
(Revised April 2024)

## SF681 B-C: Replacement of Direct Current Box (DCB) Module(s)

1. Check the base label (Form WAR259) for a completion sticker for SF681 (Form WAR261), indicating this work has been done. The base label is usually located on the passenger-side door, about 12 inches (30 cm) below the door latch. If a completion sticker is present, no work is needed. If a completion sticker is not present, proceed to the next step.
2. Park the vehicle on a level surface, place the vehicle in neutral, shut down the vehicle, and set the parking brake. Chock the tires.

### DANGER

Service and repair of the electric vehicle should only be performed by technicians that have completed HV2 or HV3 Daimler Safety Training. Decommissioning and commissioning of the HV system should only be performed by technicians that have completed HV3 Daimler Safety training. To prevent personal injury or death, or damage to the electric system, do not attempt repairs yourself.

Decommission the vehicle and verify the high voltage system is shut down. Failure to follow these steps could result in serious personal injury or death.

3. Decommission the vehicle. For instructions, see **Section 08.08** of the *eCascadia Workshop Manual*.
4. Remove the left-hand side battery deck plate. See **Fig. 17**. For instructions, see **Section 31.05** of the *eCascadia Workshop Manual*.
5. Remove the left-hand side battery protection cover that is attached to the side impact protection assembly. See **Fig. 17**.

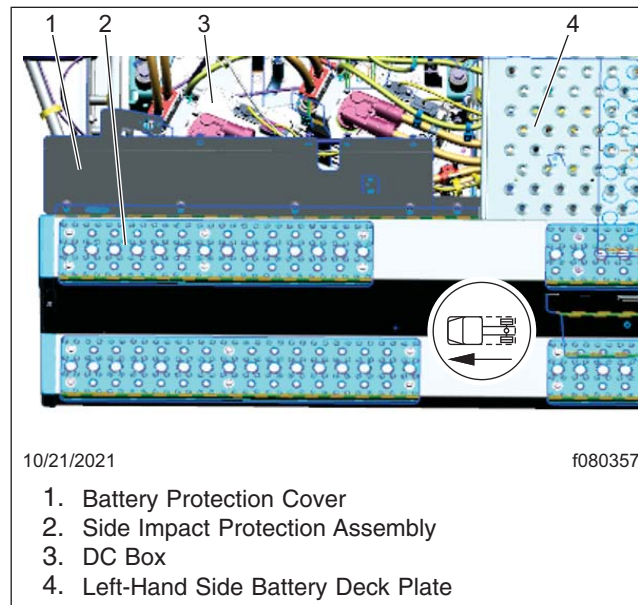

**Fig. 17, Removal of Battery Protection Cover**

6. Remove the side impact protection. For instructions, see **Section 31.03, Subject 100** of the *eCascadia Workshop Manual*.
7. Clamp the coolant lines to the DC boxes.

March 2024  
SF681 A-C  
(Revised April 2024)

8. Remove the high voltage cable clamps.

**IMPORTANT:** High voltage connectors need to be kept clean and clear of debris, fluids, and damage. A dirty or damaged connector can cause problems for energy transfer within the cable or high voltage components and can lead to high voltage system failures.

**NOTE:** To ensure the high voltage connectors are installed vertically during installation, use the tool (DSNEMG022008) to connect the three high voltage connectors.

9. Remove the high voltage connectors from the DC box(es).
10. Remove the fasteners from the ground cables, then disconnect the ground cables.
11. Disconnect the low voltage cable connectors from the DC box(es) and the front side of the ground bracket.
12. Gently move the high voltage, low voltage, and ground cables out of the way.
13. Transfer the high voltage connector protective caps from the new DC box(es) to the high voltage connections on the DC box(es) being removed.
14. Disconnect the coolant lines from the DC box(es).
15. Remove the DC box mounting bracket fasteners. See [Fig. 18](#).
16. Remove the DC box(es) and bracket from the vehicle.

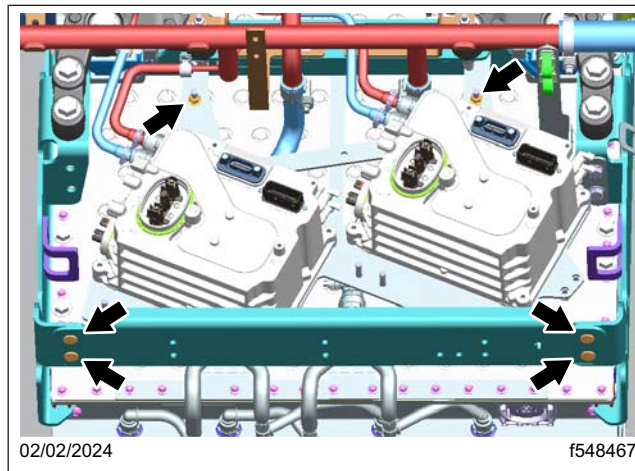

**Fig. 18, DC Box Mounting Bracket Fasteners**

March 2024  
SF681 A-C  
(Revised April 2024)

17. Remove the DC box(es) from the mounting bracket. See **Fig. 19**.

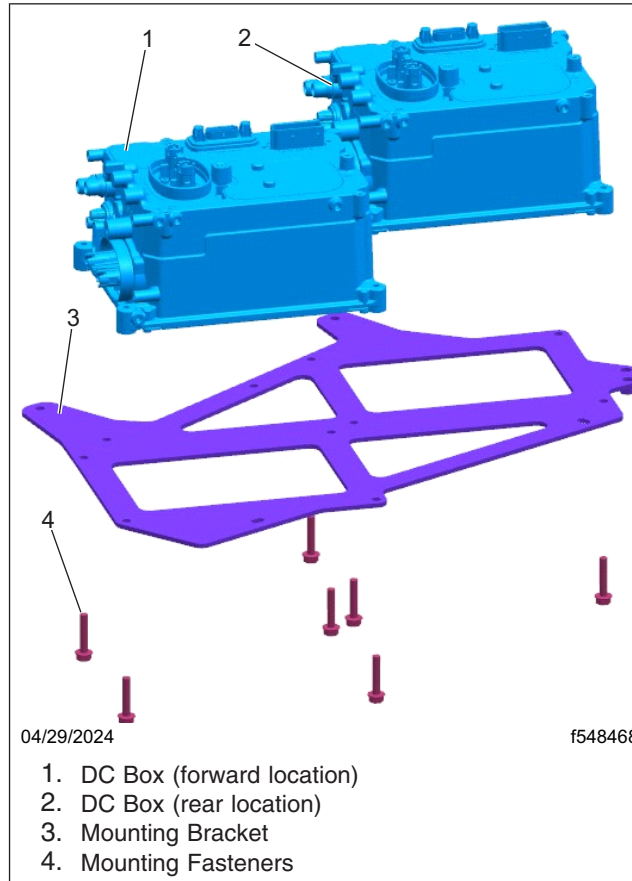

**Fig. 19, Removal of DC Box**

18. Clean any spilled coolant from the top of the battery.
19. Transfer the high voltage connector protective caps from the old DC box(es) to the new DC box(es).
20. Install the DC box(es) on the mounting bracket, and install the fasteners that attach the DC box(es) to the mounting bracket. Tighten the fasteners 115 lbf-in (1300 N-cm). See **Fig. 19**
- IMPORTANT:** Install the DC box high voltage charging control unit 1 (66-32674-003) in the forward location, and the DC box high voltage charging control unit 2 (66-32674-004) in the rear location.
21. Install the DC box(es) and bracket on the vehicle. See **Fig. 18**.
22. Install and tighten the mounting bracket fasteners.
23. Connect the coolant lines to the DC box(es).
24. Route the wiring harnesses back to the original positions.
25. Connect the low voltage connectors to the DC box(es) and the front side of the ground bracket.
26. Install the ground cable fasteners. Tighten the smaller nut and the DC box bolt 11 lbf-ft (15 N-m), and the larger nut 35 lbf-ft (48 N-m).

March 2024  
SF681 A-C  
(Revised April 2024)

**IMPORTANT:** Clean any dirt or debris from high voltage connectors before removing them. Failure to do so could increase the chance of dirt getting into the connector during installation.

27. To ensure the high voltage connectors are installed vertically during installation, use the tool (DSNEMG022008) to connect the three high voltage connectors.
28. Remove the alignment pin, and install the high voltage connector mounting fasteners.
29. Install the high voltage cable clamps, and tighten the fasteners.
30. Tighten the high voltage connector fasteners 14 lbf·ft (19 N·m).
31. Secure the low voltage harnesses and the ground cables with cable ties.
32. Install the side impact protection. For instructions, see **Section 31.03, Subject 100** of the *eCascadia Workshop Manual*.
33. Remove the block off plate of the dual port charger. See **Fig. 20**.



**Fig. 20, Location of the Block Off Plate**

34. Install the forward battery cover that is attached to the side impact protection assembly.
35. Install the left-hand side battery deck plate. For instructions, see **Section 31.05** of the *eCascadia Workshop Manual*.
36. Commission the vehicle. For instructions, see **Section 08.08** of the *eCascadia Workshop Manual*.
37. Fill and bleed the battery cooling system. For instructions, see **Section 20.01, Subject 160** of the *eCascadia Workshop Manual*.

March 2024  
SF681 A-C  
(Revised April 2024)

## SF681 A-C: Software Programming

1. Connect a 12-volt battery charger to the jump studs in the frontbox.
2. Turn the keyswitch to the ON position.
3. Connect an RP1210B-compliant vehicle diagnostic adaptor to the diagnostic connector on the vehicle. Connect the other end of the adaptor to the laptop.
4. Open DiagnosticLink®.

IMPORTANT: Make sure that DiagnosticLink is updated to the latest version (8.18 SP1 at the time of publication or newer), before programming the vehicle.

5. Go to the 'Program Device' tab, and make sure the vehicle identification number (VIN) that appears is correct. Select 'Download data from server.' See [Fig. 21](#).

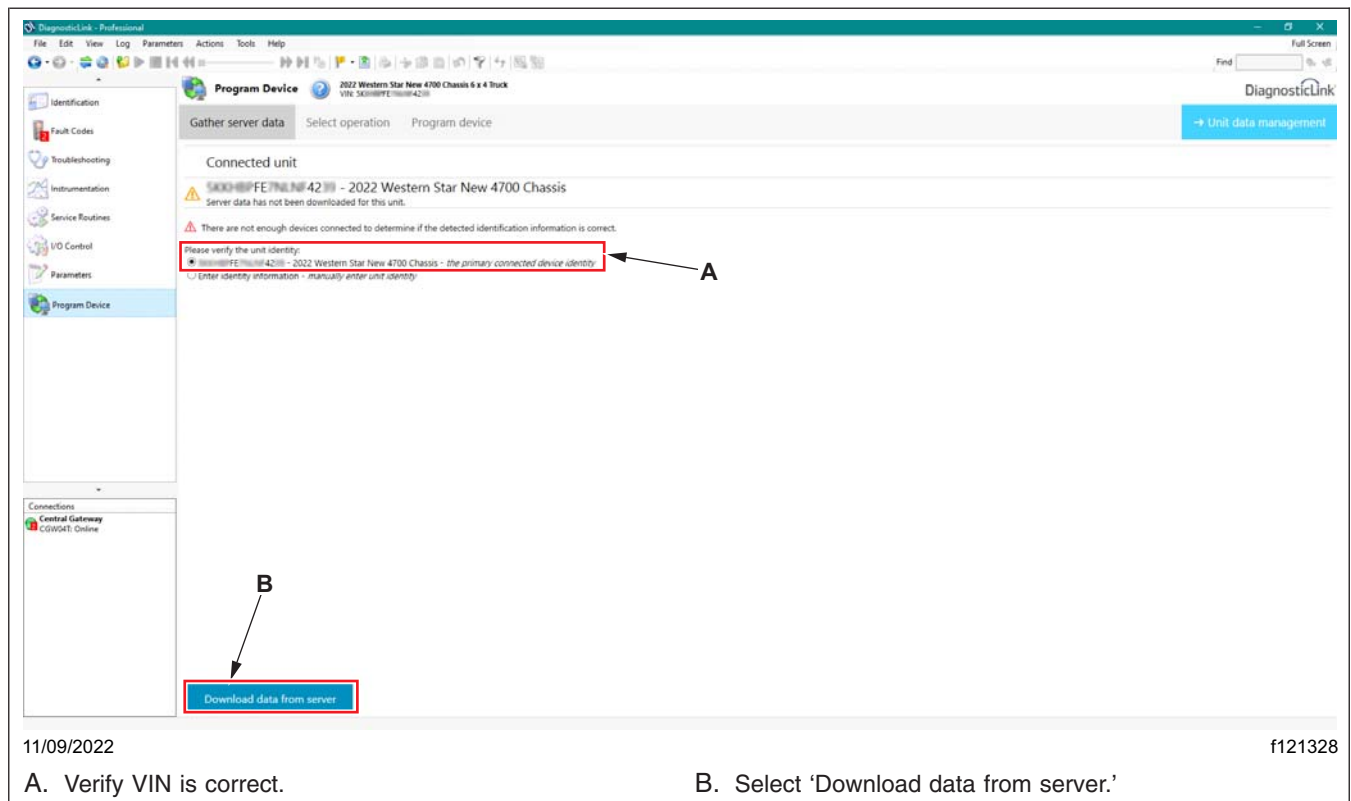

Fig. 21, Downloading Data from Server

March 2024  
SF681 A-C  
(Revised April 2024)

6. Once the data download is complete, select 'Next.' See Fig. 22. Devices with available software are listed.

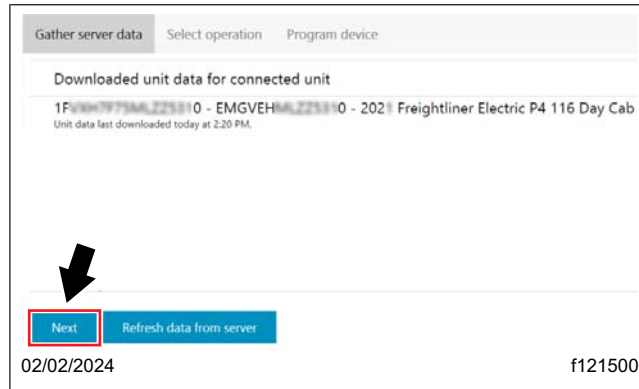

Fig. 22, Downloaded Data for Connected Unit

7. Before proceeding to program the electric common powertrain controller (ECPC) and electronic control unit (ECU), check the software version and the shift map part number. Go to the 'Identification' tab, then select and expand the 'ECPC01T - Electric Common Powertrain Controller' panel.

8. Verify the ECPC01T software version and the shift map part number. See Fig. 23.

Is the software version already updated to 'R23.11.10.00A,' and is the shift map part number showing as 'A029 448 87 02 ZGS 002' ?

**YES** → Disable the high voltage system, as instructed in step 9. Skip steps 10 through 11, and go to step 12.

**NO** → Continue with step 9.

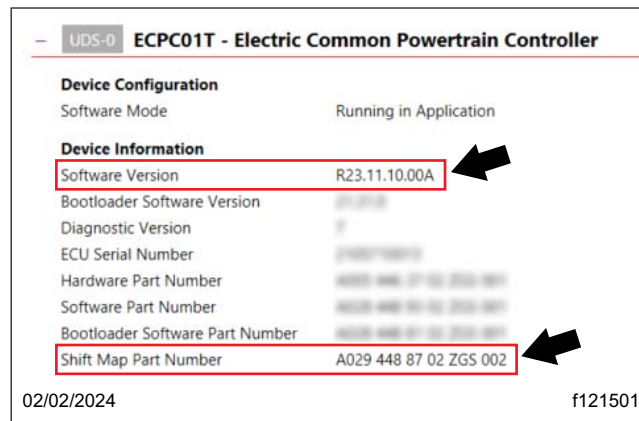

Fig. 23, ECPC01T Device Information

9. Turn the keyswitch to the OFF position. Press the ESTOP button on the dash panel, then turn the key-switch to the ON position.

March 2024  
SF681 A-C  
(Revised April 2024)

10. Follow the substeps to update the ECPC01T device software.
  - 10.1 Select 'ECPC01T' as the device to program. See [Fig. 24](#).
  - 10.2 Select 'Update Device Software' as the reprogramming operation. See [Fig. 24](#).
  - 10.3 'R23.11.10.00A' is selected as the firmware to apply to the device. Select 'Next.' See [Fig. 24](#).

The screenshot displays a software update interface with three main sections. The first section, 'Select the device to program', lists various vehicle components with radio buttons. 'ECPC01T - Electric Common Powertrain Controller - OK' is selected and highlighted with a red box, with an arrow labeled 'A' pointing to it. The second section, 'Select the reprogramming operation you wish to take place', offers three options: 'Replace Device Settings with Server Configuration', 'Update Device Software' (selected and highlighted with a red box, with an arrow labeled 'B' pointing to it), and 'Change Data Set'. The third section, 'Select the firmware to apply to the device', shows 'R23.11.10.00A - 0284489302\_001 - ECPC01T - R23.11.10.00A - Additional reprogramming is required to use this software.' selected. At the bottom, 'Back' and 'Next' buttons are visible, with 'Next' highlighted by a red box and an arrow labeled 'C' pointing to it.

02/02/2024 f121502

A. Select 'ECPC01T' as the device to program.  
B. Select 'Update Device Software' as the reprogramming operation.  
C. Select 'Next.'

**Fig. 24, Updating ECPC01T Device Software**

- 10.4 Review the programming information, then select 'Start.'
- 10.5 Once the programming is complete, a message is displayed: 'Programming was successfully completed.' Select 'Finish.'

March 2024  
SF681 A-C  
(Revised April 2024)

11. Follow the substeps to update the ECPC01T data set.
  - 11.1 With 'ECPC01T' still selected as the device to program, now select 'Change Data Set' as the reprogramming operation. See [Fig. 25](#).
  - 11.2 'EMG Long Haul Vehicle Shiftmap - 0294488702\_002' is selected as the dataset to apply to the device. Select 'Next.' See [Fig. 25](#).

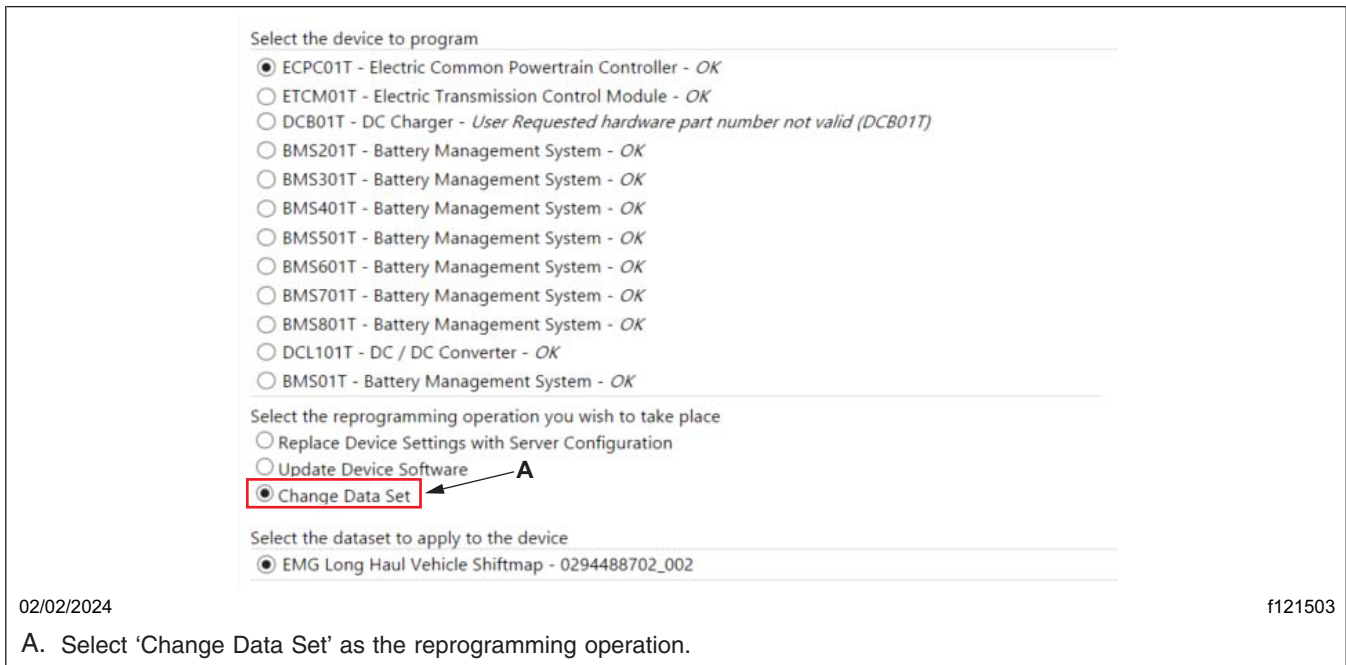

**Fig. 25, Updating ECPC01T Data Set**

- 11.3 Review the programming information, then select 'Start.'
  - 11.4 Once the programming is complete, a message is displayed: 'Programming was successfully completed.' Select 'Finish.'
12. Before proceeding to program the battery management system (BMS) ECUs, check the software version of the BMS ECUs. Go to the 'Identification' tab, then select and expand the respective BMS ECU panels.
  13. Verify the BMS ECU software version. See [Fig. 26](#).

Is the software version already updated to '22.25.5'?

**YES** → Go to step 15, on page 26.

**NO** → Continue with step 14.

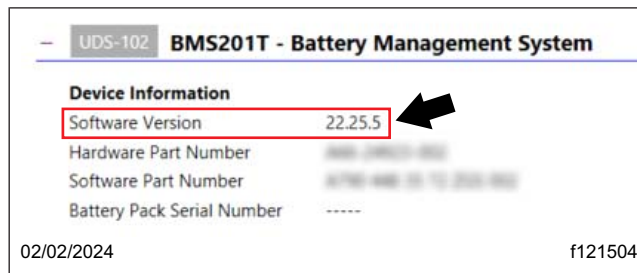

**Fig. 26, BMS201T Device Information**

March 2024  
SF681 A-C  
(Revised April 2024)

14. Follow the substeps to update the BMS01T device software.

NOTE: BMS01T is at the bottom of the list as it has the highest source address.

14.1 Select 'BMS01T' as the device to program. See Fig. 27.

14.2 Select 'Update Device Software' as the reprogramming operation. See Fig. 27.

14.3 '22.25.5' is selected as the firmware to apply to the device. Select 'Next.' See Fig. 27

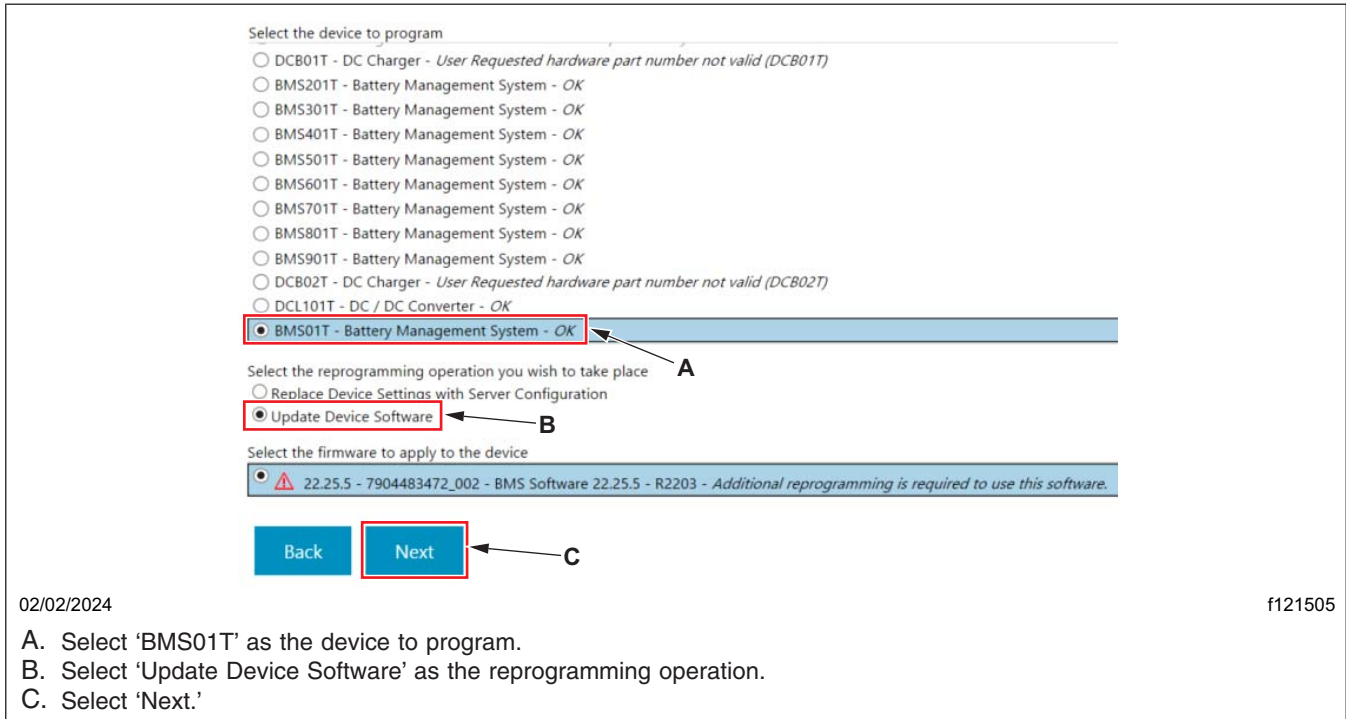

Fig. 27, Updating BMS01T Device Software

14.4 Review the programming information, then select 'Start.'

14.5 Once the programming is complete, a message is displayed: 'Programming was successfully completed.' Select 'Finish.' See Fig. 28.

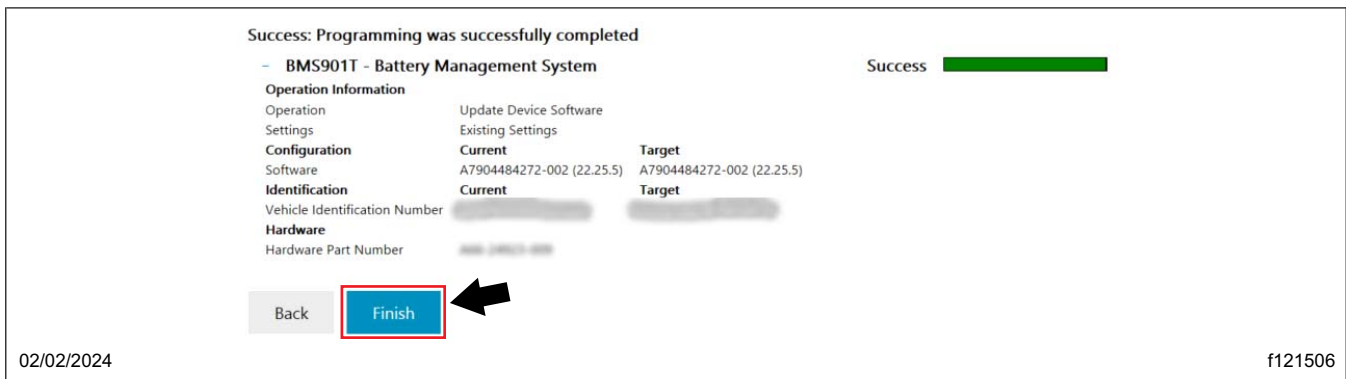

Fig. 28, Programming Successful for BMS901T

March 2024  
SF681 A-C  
(Revised April 2024)

NOTE: Each vehicle may have six to nine BMS ECUs, depending on the installed battery configuration.

14.6 Repeat substeps 14.1 through 14.5 to program the remaining BMS ECUs.

15. Follow the substeps to update the ETCM01T device software.

15.1 Select 'ETCM01T' as the device to program. See Fig. 29.

15.2 Select 'Update Device Software' as the reprogramming operation. See Fig. 29.

15.3 'NAMT231400' is selected as the firmware to apply to the device. Select 'Next.'

The screenshot shows the 'Program Device' interface for a Freightliner Electric P4 Day Cab. The VIN is 1F... and the powertrain is EMOBILITY-eDrive. The interface has three tabs: 'Gather server data', 'Select operation', and 'Program device'. The 'Select operation' tab is active. It displays unit data and error counts. Under 'Select the device to program', 'ETCM01T - Electric Transmission Control Module - OK' is selected (indicated by a red box and arrow 'A'). Under 'Select the reprogramming operation you wish to take place', 'Update Device Software' is selected (indicated by a red box and arrow 'B'). Under 'Select the firmware to apply to the device', 'NAMT231400 - 0044488309\_001 - ETCM NAMT231400 software - Additional reprogramming is required to use this software.' is selected.

03/06/2024 f121518

A. Select 'ETCM01T' as the device to program.  
B. Select 'Update Device Software' as the reprogramming operation.

Fig. 29, Updating the ETCM01T Device Software

March 2024  
SF681 A-C  
(Revised April 2024)

15.4 Review the programming information, then select 'Start.' See [Fig. 30](#).

**Program Device** VIN: 1FVXH7F75MLZZ5310 Transmission: EMOBILITY-eDrive Powertrain Engine: EMOBILITY-eDrive Powertrain

Gather server data Select operation **Program device**

1FVXH7F75MLZZ5310 - EMGVEH... - 2021 Freightliner Electric P4 Day Cab

Unit data last downloaded today at 1:18 PM.  
Powertrain status: 5 device errors  
Chassis status: 7 device errors and 7 missing devices

Please review the information shown. If this is correct, click the Start button

- ETCM01T - Electric Transmission Control Module

Operation Information		
Operation	Update Device Software	
Settings	Existing Settings	
Configuration		
Software	<b>Current</b> A0044488309-001 (NAMT231400)	<b>Target</b> A0044488309-001 (NAMT231400)
Identification		
Vehicle Identification Number	<b>Current</b> 1F...0	<b>Target</b> 1F...0
Hardware		
ECU Serial Number	000000000...0	
Hardware Part Number	A0...-001	

Back Next **Start** A

03/06/2024 f121519

A. Select 'Start.'

**Fig. 30, Starting to Update the ETCM01T Device Software**

- If the ECPC ECU has been programmed, perform the electric refrigerant compressor (ERC) run-in procedure. Has the ECPC software been updated to 'R23.11.10.00A' in steps 10 through 11?  
**YES** → Continue with step 17.  
**NO** → Go to step 19.
- To enable the high voltage system, turn the keyswitch key to OFF position, release the ESTOP button on the dash panel, then turn the keyswitch to the ON position.

March 2024  
SF681 A-C  
(Revised April 2024)

18. Follow the substeps to perform the ERC run-in procedure.
  - 18.1 Open the 'Refrigerant System Management' panel. This panel is located on the 'Service Routines' tab in DL version 8.19 SP1 and later. In DL versions 8.19 and earlier, it is under the 'I/O Controls' tab.
  - 18.2 Set the blower fan speed to a minimum of level 8.
  - 18.3 Select 'Start' to re-learn the ERC run-in. See [Fig. 31](#).

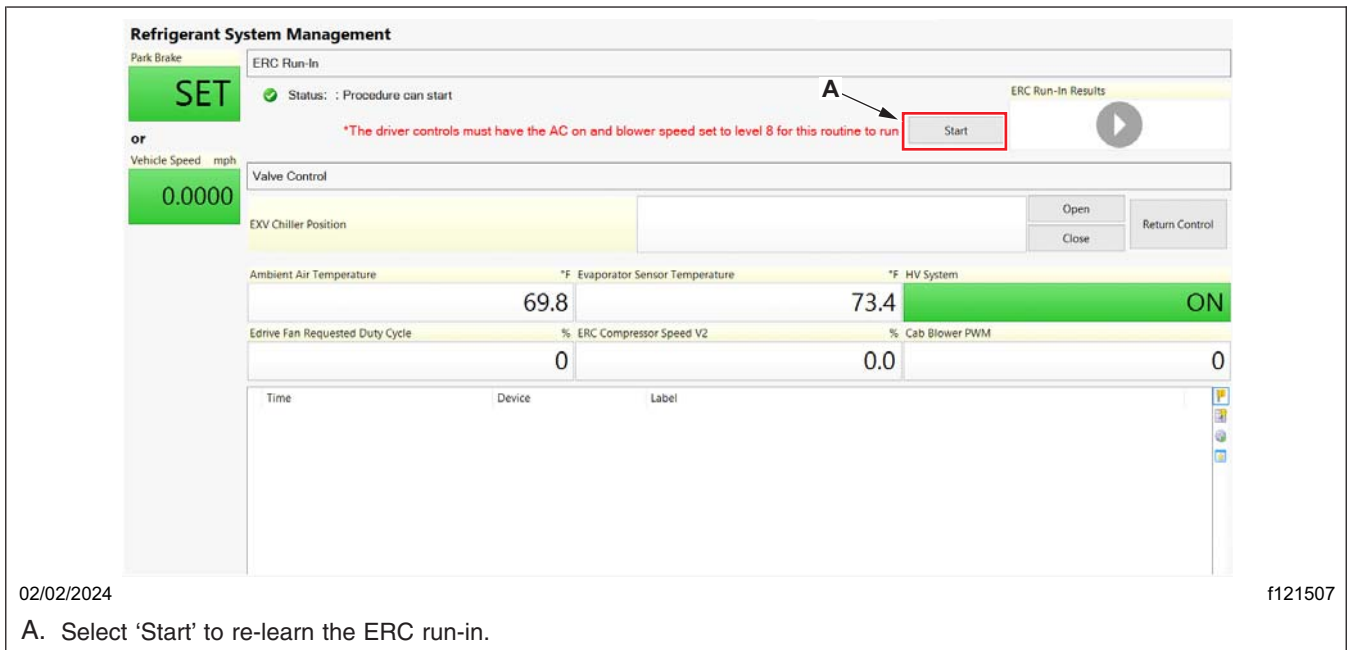

**Fig. 31, ERC Run-In Panel**

19. Once the ERC run-in procedure is complete, perform the odometer synchronization procedure.
  - 19.1 Right-click on the 'Connections' panel, located in the bottom-left corner of the screen, then select 'Close Connections.' See [Fig. 32](#).

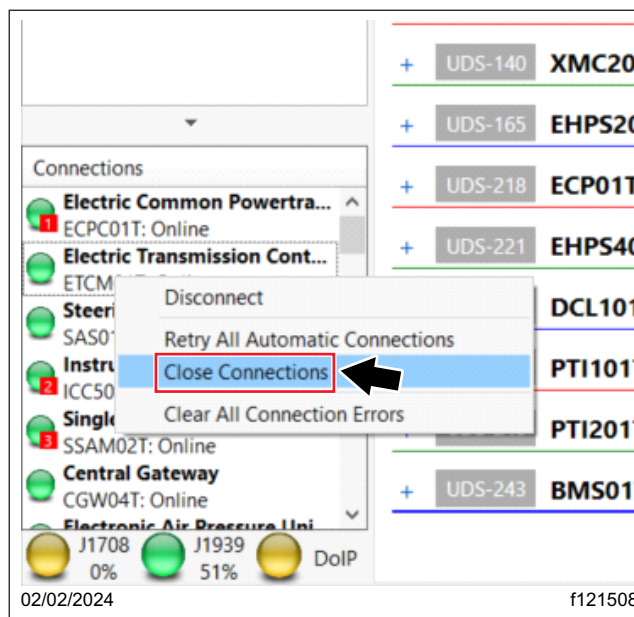

**Fig. 32, Closing Connection to all the ECUs**

March 2024  
SF681 A-C  
(Revised April 2024)

IMPORTANT: Odometer synchronization must be achieved within 30 seconds of connecting DiagnosticLink to the ECPC ECU.

- 19.2 From the menu bar, select 'Tools,' then select 'Options.'
- 19.3 In the 'Options' window, go to the 'Connection' tab. See Fig. 33.
- 19.4 Select the 'Select None' button. See Fig. 33.
- 19.5 In the 'Proprietary Devices to Automatically Connect' panel, choose only the three devices listed below, then select 'OK.' See Fig. 33.
  - UDS-0 – Common Powertrain Controller
  - UDS-23 – Instrument Cluster
  - UDS-37 – Central Gateway

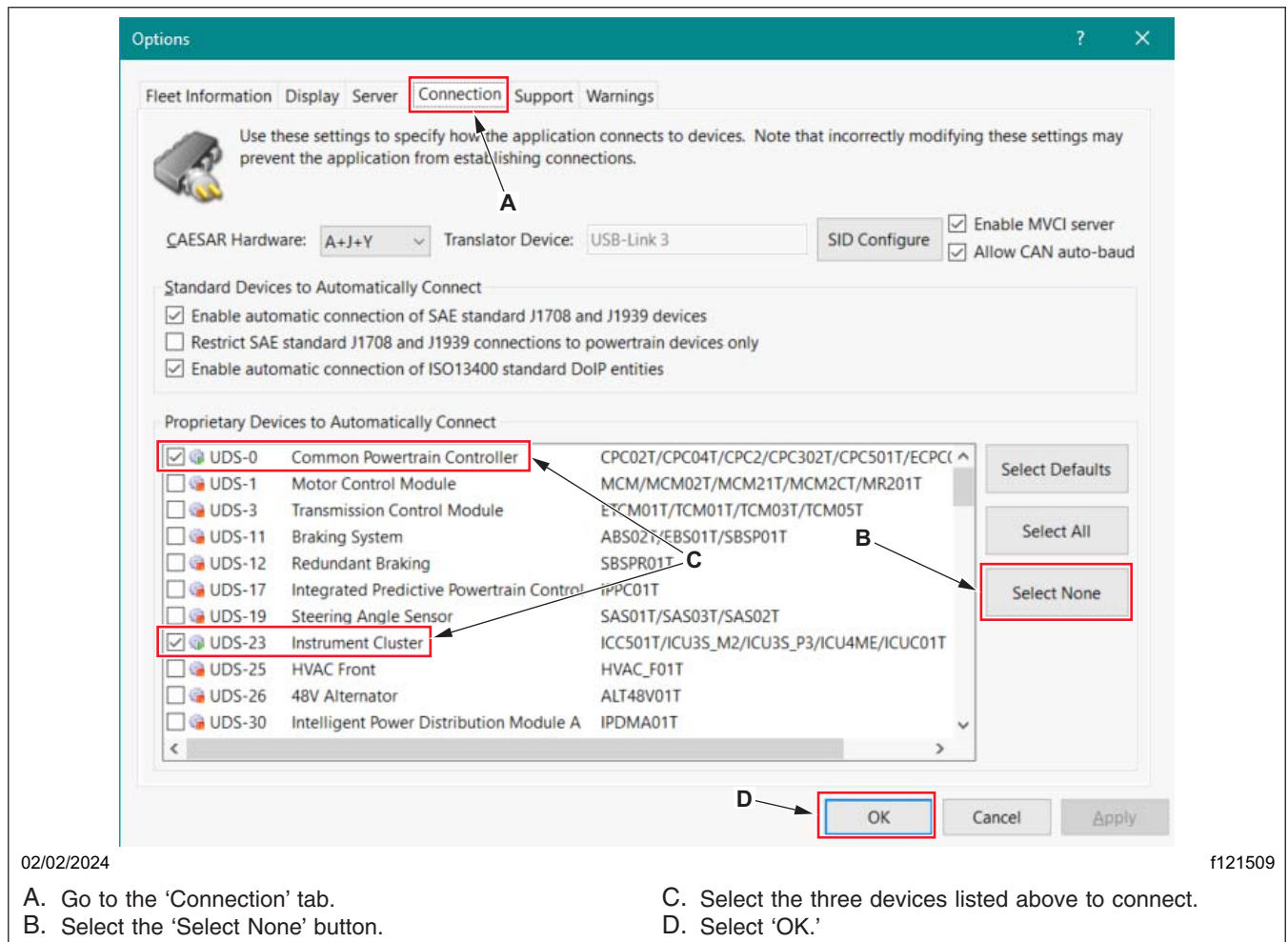

Fig. 33, Connection Tab in the Options Window

March 2024  
SF681 A-C  
(Revised April 2024)

IMPORTANT: The 30-second time period begins after selecting 'OK' in substep 19.6.

19.6 A pop-up window appears. Select 'OK.'

19.7 From the menu bar, select 'Actions,' then select 'Set Odometers.'

19.8 In the 'Set Odometers' window, select the 'Sync System to Instrument Cluster' button.

19.9 DDEC reports are not applicable for battery electric vehicles. In the pop-up window that appears, select 'OK.' See [Fig. 34](#).

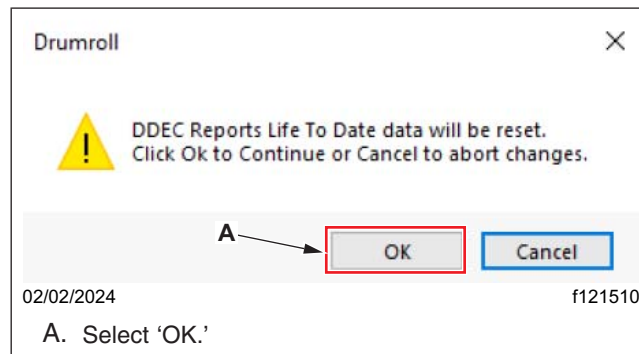

**Fig. 34, DDEC Reports Pop-Up**

19.10 Once the odometer synchronization is complete, the label indicates 'Done,' and a message is displayed: 'The odometer has been set up.' Select the 'Close' button. See [Fig. 35](#).

If the odometer synchronization is not completed within 30 seconds of connecting to the ECPC ECU, an error message, as shown in [Fig. 36](#), is displayed: 'Conditions not correct(NRC\$22).'

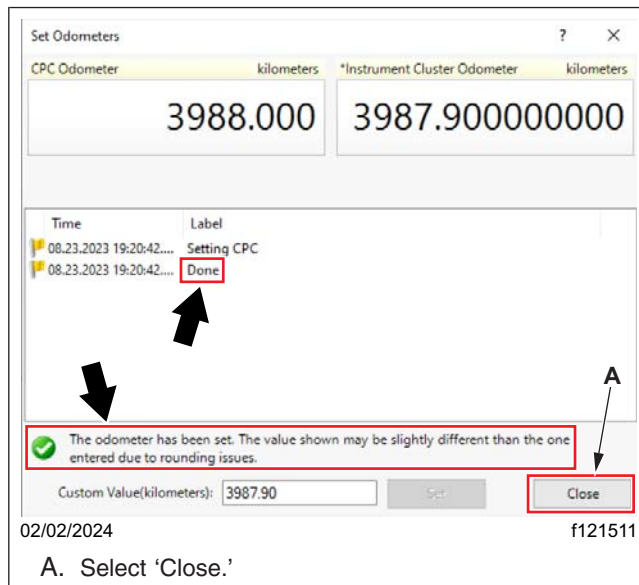

**Fig. 35, Odometer Synchronization Completed**

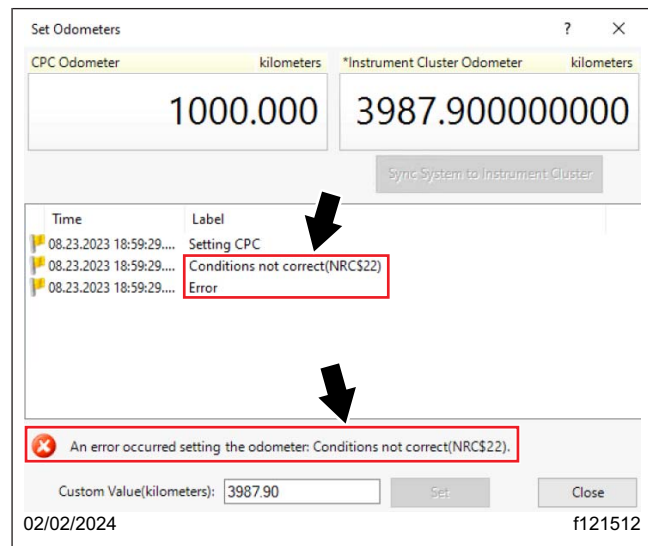

**Fig. 36, Odometer Synchronization Error**

- Turn the keyswitch to the OFF position, then turn it back to the ON position again.
- Repeat substeps 19.1 through 19.10 to attempt to synchronize the odometer again.

**March 2024  
SF681 A-C  
(Revised April 2024)**

20. Follow the substeps to write the VIN to the new DC box(es).
  - 20.1 From the menu bar, select 'Actions,' then select 'Set Vehicle Identification Number.'
  - 20.2 In the 'Set Vehicle Identification Number' window that appears, the VIN automatically populates for the connected vehicle.
  - 20.3 Select the 'Set VIN' button.
  - 20.4 Allow the process to complete, then select the 'Close' button.
21. Clean a spot on the base label (Form WAR259), and attach a campaign completion sticker for SF681 (Form WAR261), indicating this work has been completed.