



GROUP	MODEL
TRA	2021-2024MY Multiple Models
NUMBER	DATE
108 (Rev 1, 4/25/2024)	September 2023

TECHNICAL SERVICE BULLETIN

SUBJECT: **4WD COUPLING ACTUATOR ASSEMBLY REPLACEMENT**

NOTICE

This bulletin has been revised to include additional information. New/revised sections of this bulletin are indicated by a black bar in the margin area.

This bulletin provides information to replace the AWD coupling actuator assembly on some 2021-2024MY Kia AWD models listed on page 4. The affected vehicles may exhibit an inoperative AWD system (also referred to as 4WD) capability concern which may be caused by abnormal wear of the motor brushes inside the actuator assembly. This condition will cause the warning lamps on the instrument cluster to illuminate with stored DTC(s) P195800 and/or P19600. Follow the procedure outlined in this publication to inspect and, if necessary, replace the AWD coupling actuator assembly on the applicable vehicles.

DTC Description:

P195800 - 4WD Torque Error

P196000 - 4WD Bleeding Pressure Error

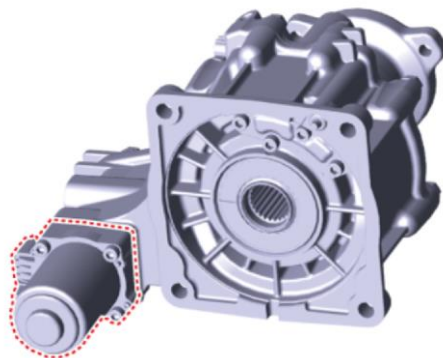

NOTICE

A Technical Service Bulletin is a field fix repair program without customer notification that may be performed during the warranty period. Any dealer requesting to perform this repair outside the warranty period will require DPSM approval.

Replacement Procedure:

1. Confirm an inoperative AWD/4WD condition is present with stored DTC(s) P195800 and/or P196000.
 - If DTC(s) is/are not stored, then [this TSB does not apply](#).

2. Disconnect the negative (-) battery terminal.
3. Remove the 4WD Coupling Assembly (A) by referring to the "4 Wheel Drive (4WD) System → Coupling Assembly → Direct Electro Hydraulic Actuator Coupling → Repair procedures" chapter in the applicable Shop Manual on KGIS.



Tightening torque for bolts:
41.9 - 47.7 lb.ft (58.9 - 64.7 N.m)

ⓘ IMPORTANT

DO NOT tilt the AWD/4WD coupling assembly on its side or remove the actuator with the coupling assembly installed on the vehicle as the existing oil may leak out.

**TECH TIP**

Only the rear side of the propeller shaft needs to be removed to remove the coupling assembly.

4. Using an air gun, clean the exterior area of the actuator (B) to prevent any dust/debris entering the coupling assembly before disassembly.

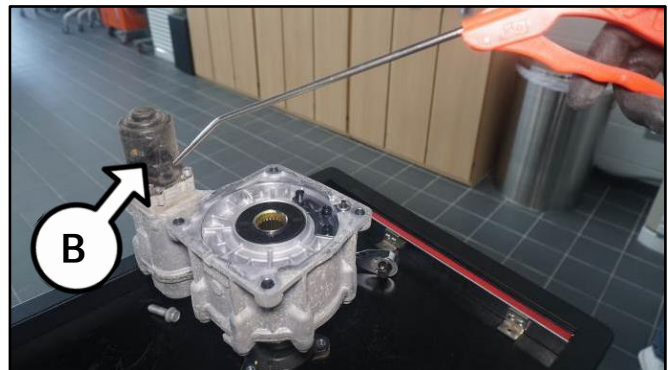
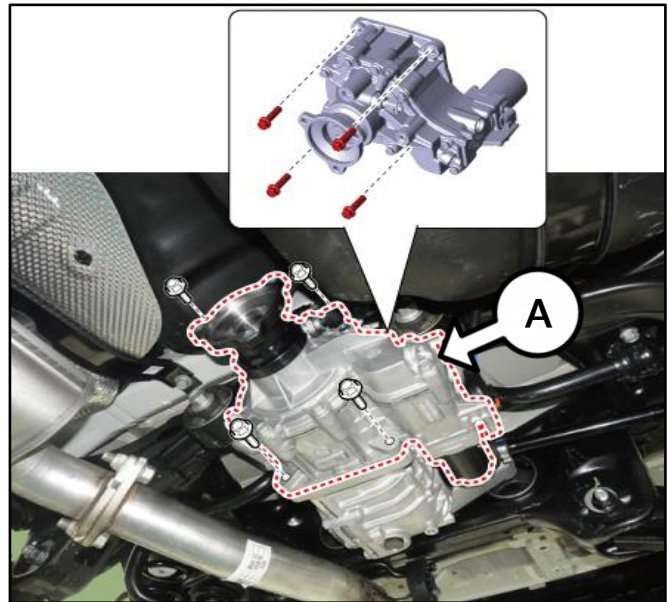

SUBJECT:

4WD COUPLING ACTUATOR ASSEMBLY REPLACEMENT

- Loosen the four (4) bolts to remove the AWD/4WD coupling actuator (B).

Note: Keep the coupling assembly (A) in the vertical position.



Tightening torque for 4WD Coupling Actuator Bolts:
7.2 - 8.6 lb.ft (9.8 - 11.7 N.m)

ⓘ IMPORTANT

DO NOT tip the 4WD coupling assembly on its side as the existing oil may leak out.

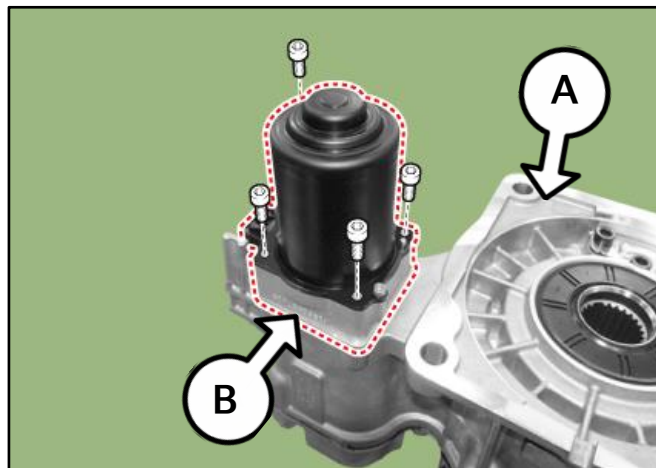

- To avoid oil spillage from the actuator mounting area, press down on the air breather valve (C) to drain the accumulated oil back into the coupling assembly (A) housing.

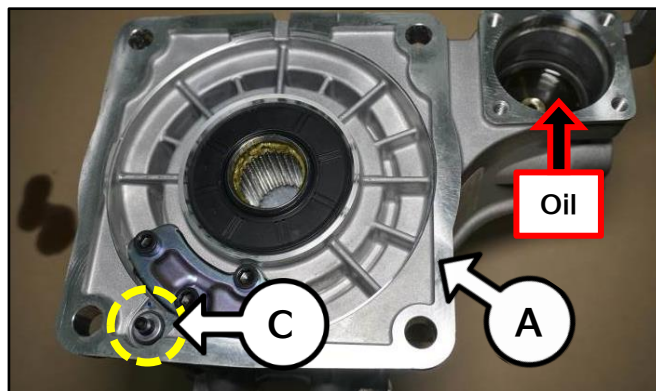

- Install 'new' actuator (B) onto coupling assembly (A).

Note: Lightly lubricate the O-ring prior to installing the new actuator.

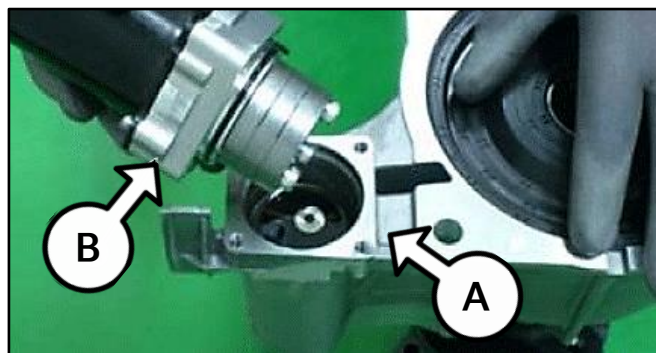

- Reinstall all removed parts in reverse order.

Note: Install 'new' mounting bolts (D) when reinstalling the propeller shaft.

📄 NOTICE

DO NOT reuse the 'old' removed propeller shaft mounting bolts (D).

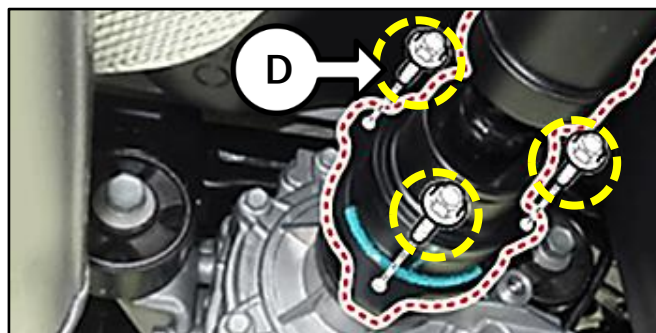

- Confirm normal vehicle operation.





SUBJECT:

4WD COUPLING ACTUATOR ASSEMBLY REPLACEMENT**AFFECTED VEHICLE RANGE:**

Model Year	Model	Production Date Range
2021-2023MY	K5 (DL3a)	August 25, 2020 to December 20, 2023
2021-2022MY	Sorento (MQ4a)	September 18, 2020 to December 15, 2023
2021-2023MY	Sorento (MQ4 HEV)	September 16, 2020 to August 16, 2023
2022-2023MY	Sorento (MQ4 PHEV)	June 29, 2021 to August 16, 2023
2023-2024MY	Sportage (NQ5)	December 15, 2021 to August 16, 2023
	Sportage (NQ5a)	January 12, 2021 to December 18, 2023
	Sportage HEV (NQ5 HEV)	February 15, 2022 to August 16, 2023
	Sportage PHEV (NQ5 PHEV)	June 6, 2022 to August 16, 2023

REQUIRED PART:

Model	Part Name	Part Number	Figure	Qty.
All	Actuator Assembly	47899 4G300		1
NQ5, NQ5 P/HEV	Propeller Shaft Mounting Bolts	49129 L8000		3
DL3, NQ5a MQ4a MQ4 P/HEV		11435 10256K		

WARRANTY INFORMATION:**N Code: I12 C Code: ZZ3**

Claim Type	Causal P/N	Qty.	Repair Description	Labor Op Code	Op Time	Replacement P/N	Qty.
W	47899 4G300	1	Actuator Assembly Replacement	47801F01	0.7 M/H	49129 L8000 or 11435 10256K	3