

Volvo Car USA LLC
Technical Journal

Technical Journal Title Long Range PHEV ERAD Knocking Noise Repair Kit		Ref. No. TJ 36894.1.0	
Issuer (Dept.) Technical Service		Issue Date 3/21/24	Status Date 4/16/24
Car Market United States and Canada	Partner 3 US 7510 Volvo Car USA	Function Group 4632	
Function Description Electrical rear axis drive		Page Page 1 of 9	

Attachment

File Name	File Size
TJI-528981-1_1_7_en-US (1).pdf	2.0206 MB

DESCRIPTION:

If a customer notices a knocking noise from the ERAD during acceleration or deceleration at low speeds, please follow the advice under "Service."

ERAD = Electric Rear Axle Drive

PHEV = Plug-In Hybrid Electric Vehicle

CSC Customer Symptom Codes

Code	Description
8N	Driving/Unusual noise/Unsure when/at all times
F2	Driving/Unusual noise/During acceleration
ZE	Idling/Unusual noise
D2	Front/rear axle/Unusual noise

DTC Diagnostic Trouble Codes

Vehicle Type

Type	Eng	Eng Desc	Sales	Body	Gear	Steer	Model Year	Plant	Chassis range	Struc Week Range
224	H6	BH6PHEV					2022-2023		-	202147-202307
225	H6	BH6PHEV					2022-2023		-	202147-202307
238	H6	BH6PHEV					2022-2023		-	202201-202307
246	H6	BH6PHEV					2022-2023		-	202147-202307
256	H6	BH6PHEV					2022-2023		-	202147-202307

Technical Journal 36894.1.0

SERVICE:

First please watch the attached video (TJ_36894_1.mp4) to ensure the customer's vehicle makes the noise addressed in this technical journal.

A repair kit is now available instead of replacing complete ERAD units for this issue.

- **Please order part number 32411580 and follow the attached instructions (TJI-528981-1_1_7_en-US).**

Warranty claim info:

To get a warranty claim accepted for a job described in this TJ, use the corresponding VST OP number stated in this TJ.

Note that the TJ number must be stated in the repair order text.

Failing Part: 32411580 NOTE the gaskets included in the repair kit only need to be replaced if damaged. Also, grease is not included in the kit and needs to be ordered separately.

VST Operation Number

VST Operation Number	Description
98298-2	Bearing, ERAD, cleaning acc. to TJ
97733-3	High voltage battery disconnect/connect and insulation measurement acc. QB/TJ

VEHICLE REPORT:

Yes, please submit a Vehicle Report if the service solution described in this TJ has no effect. Use concern area "Vehicle Report" and sub-concern area "Support Needed," use function group 4632.

To view TJ attachment continue to next page. This TJ has one attachment.



Volvo Car Customer Service

TJ Instruction VCC-528981-1

Title	ERAD bearing	Page	1 (7)
Action	Product fix	Operation number:	98298-2 97733-3

Issue	Date	Reason
1	2024-03	First issue

Affected vehicles

Model year	Model	Transmission
2022, 2023	S60 (19-)	TG-81SD
2022, 2023	S90 (17-)	TG-81SD
2022, 2023	S90L	TG-81SD
2022, 2023	V60 (19-)	TG-81SD
2022, 2023	V90 (17-)	TG-81SD
2022, 2023	XC60 (18-)	TG-81SD
2022, 2023	XC90 (16-)	TG-81SD

Materials

Materials	Qty.	Part No.	Notes
Abrasive cloth	1	9511024	
Splines grease	1	1161748	

Color symbols

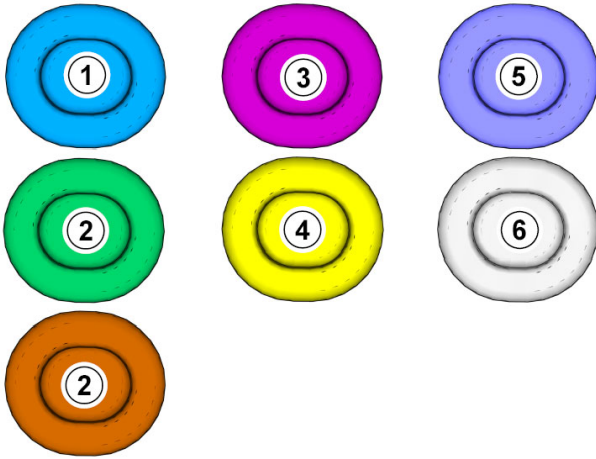

Note! This colour chart displays (in colour print and electronic version) the importance of the different colours used in the images of the method steps.

- 1 . Used for focused component, the component with which you will do something.
- 2 . Used as extra colors when you need to show or differentiate additional parts.
- 3 . Used for attachments that are to be removed/installed. May be screws, clips, connectors, etc.
- 4 . Used when the component is not fully removed from the vehicle but only hung to the side.
- 5 . Used for standard tools and special tools.
- 6 . Used as background color for vehicle components.

Removal

Remove electric rear axle drive ERAD , refer to:

- Removal, replacement and installation
- 4 - Power transmission
- 46 - Rear axle, drive shafts
- 465 - final drive (front and rear)

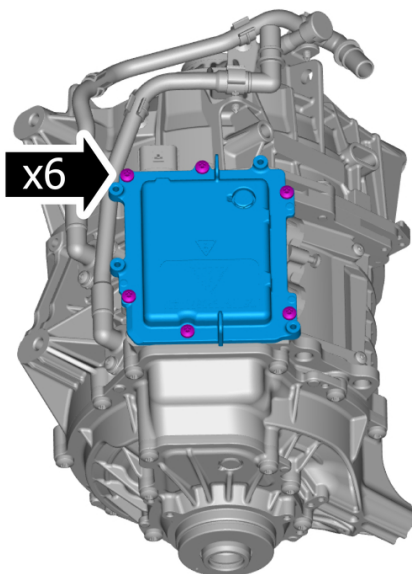

Remove the screws.

Remove the marked part.

Torque:

High voltage wiring harness lid, ERAD ,
9 Nm

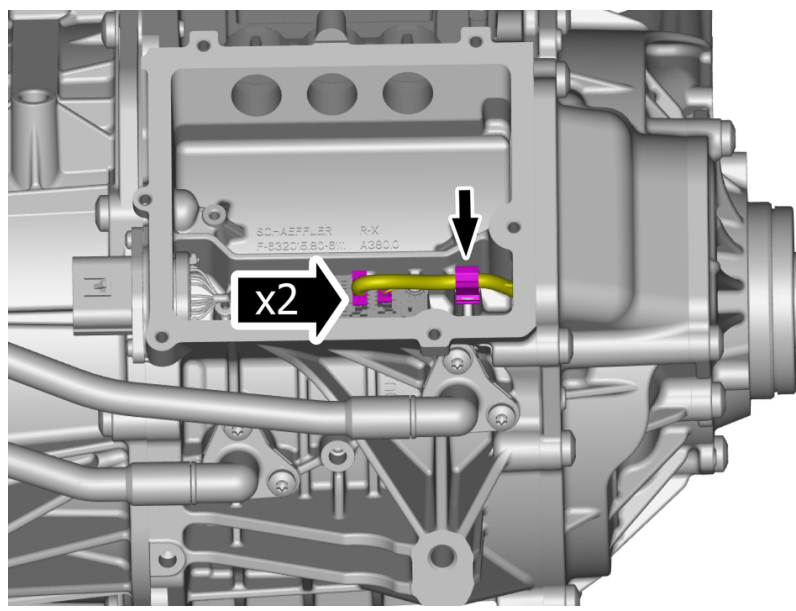

Disconnect the connectors.
Loosen the fastener.

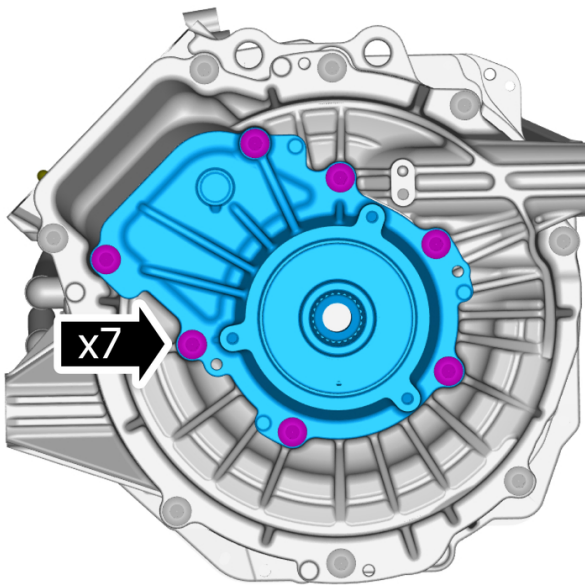

Caution! Take extra care when handling the components.

Remove the screws.
Remove the marked parts.

Torque:

Inner shaft lid screw, ERAD , 23 Nm

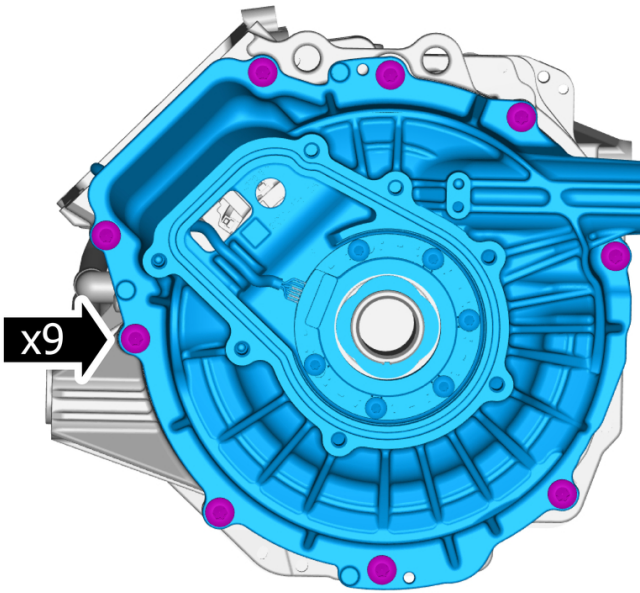

Caution! Take extra care when handling the component.

Remove the screws.
Remove the marked part.

Torque:

Electric motor cover screw, ERAD , 23 Nm

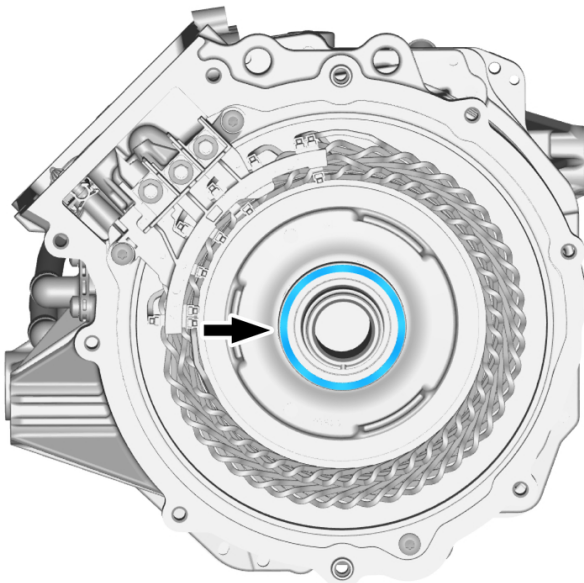

Remove the marked part.

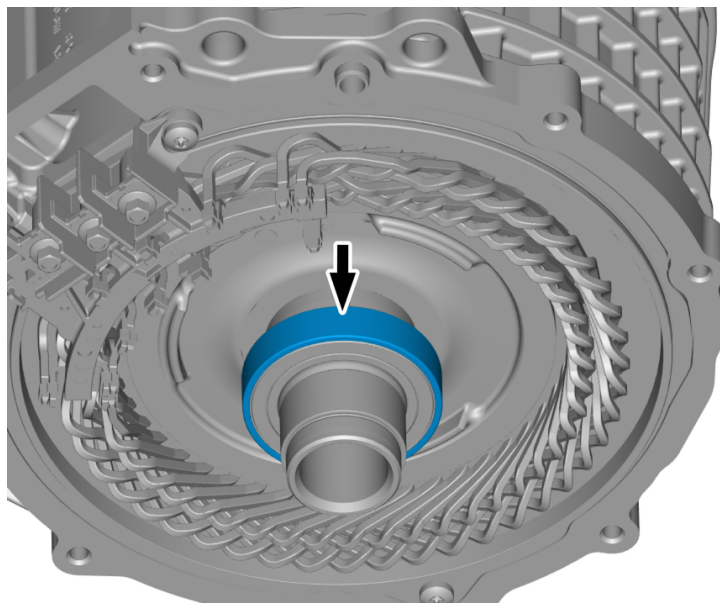

Caution! Make sure that the surface is clean and free of foreign material.

Clean the marked area.

Use: Abrasive cloth , 9511024

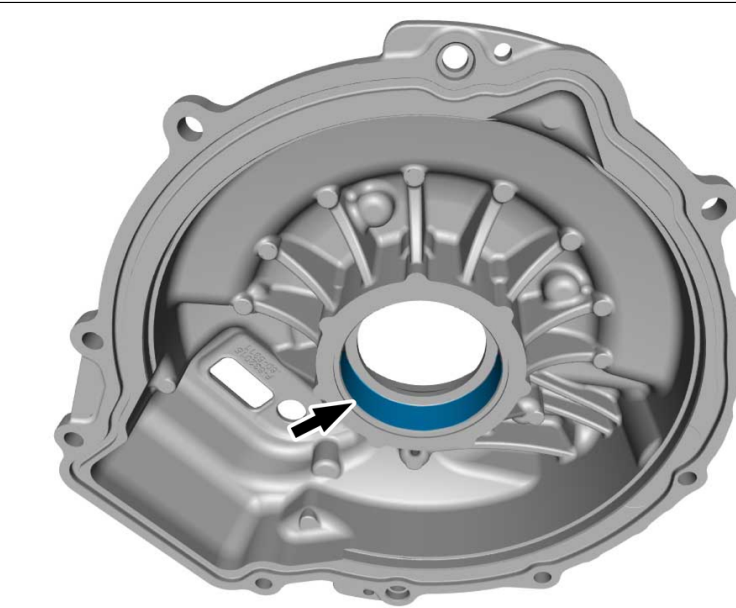

Caution! Make sure that the surface is clean and free of foreign material.

Clean the marked area.

Use: Abrasive cloth , 9511024

Installation

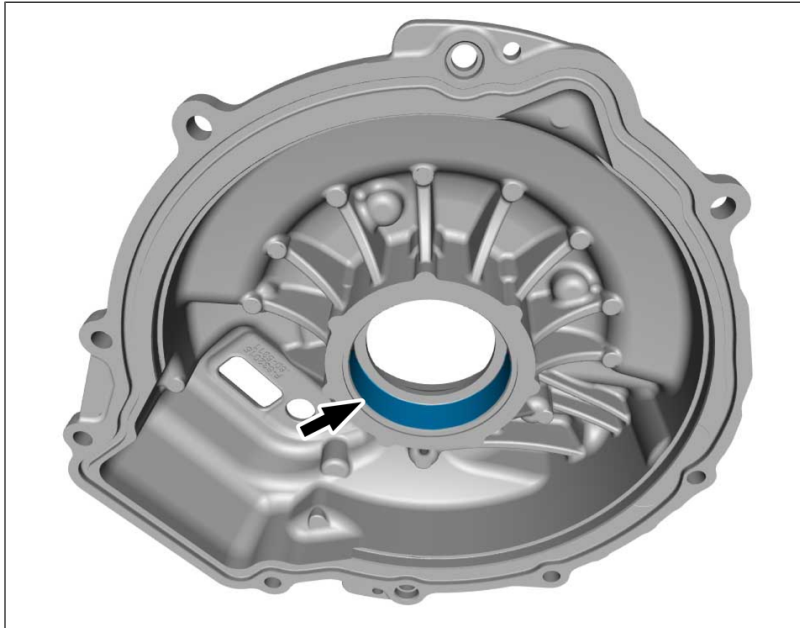

Apply grease on the area indicated.
Apply a thin and even layer.

Use: Splines grease , 1161748

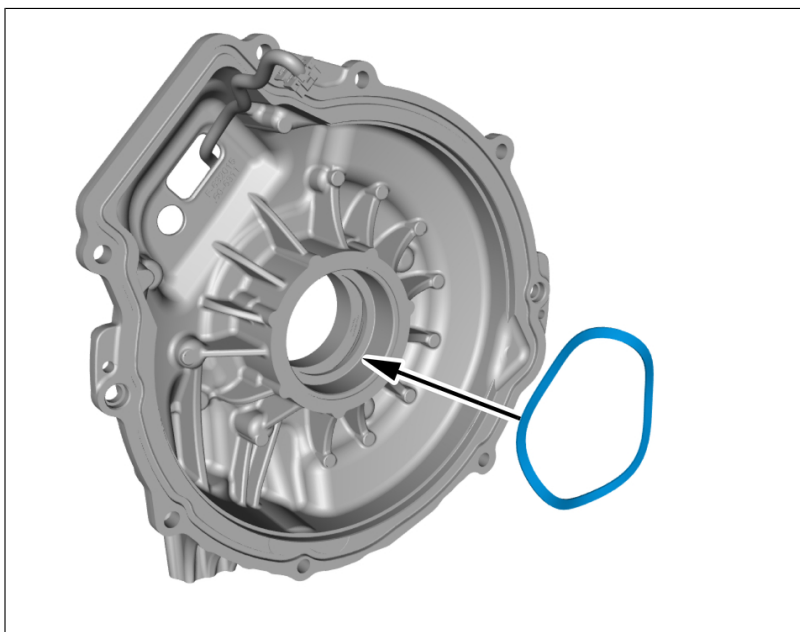

Install the marked component.

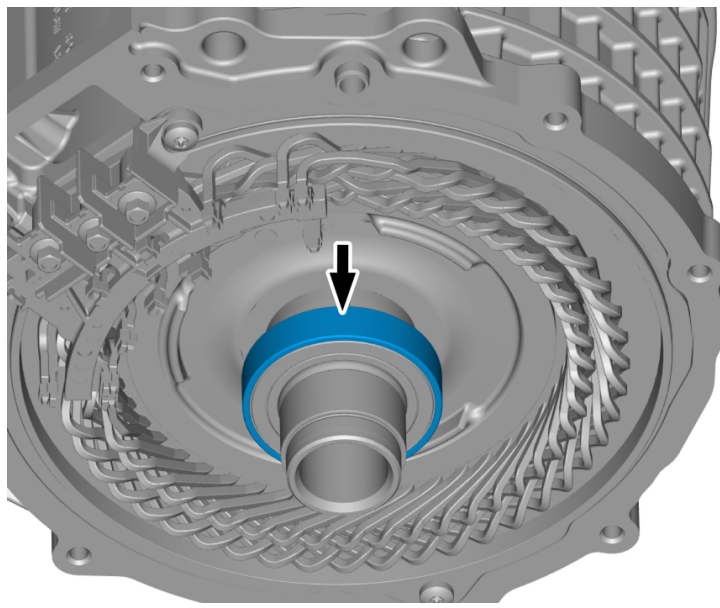

Apply grease on the area indicated.
Apply a thin and even layer.

Use: Splines grease , 1161748

To install, reverse the removal procedure.