

April 12, 2024

Version 4

Warranty Extension: 2017-18 CR-V: Software Update with A/C Control Unit Replacement; DTC P0300, P0301, P0302, P0303, P0304, or P0172; Whirling Noise from Engine

Supersedes 19-032, dated June 18, 2019, to revise the information.

WARRANTY CLAIM INFORMATION

Year	Model	Trim	VIN Range
2017-18	CR-V	EX, EX-L, Touring	Check the iN VIN status for eligibility.

REVISION SUMMARY

Under REPAIR PROCEDURE B, an image in step 13 was revised.

BACKGROUND

Under certain circumstances, the vehicle may experience driveability issues, which may result in DTCs P0300 (random misfire detected), P0301 (No. 1 cylinder misfire detected), P0302 (No. 2 cylinder misfire detected), P0303 (No. 3 cylinder misfire detected), P0304 (No. 4 cylinder misfire detected), or P0172 (fuel system too rich) or a whirling noise coming from the engine compartment.

NOTE

Check to see if the vehicle was repaired as stated in S/B 18-147. If a repair was completed as stated in S/B 18-147, see CORRECTIVE ACTION to determine if further action is necessary.

To ensure customer confidence in our product, Honda is extending the powertrain warranty from the original 5 years/60,000 miles to 6 years with unlimited mileage from the original sale date. This warranty extension applies to any engine components, such as camshafts, rocker arm assemblies, or spark plugs, requiring repair due to damage resulting from those concerns identified in the first paragraph. The ECU and TCM software is covered under the vehicle's emissions warranty beyond 6 years. Check iN for further details.

This warranty extension will not apply to any vehicle that has ever been declared a total loss or sold for salvage by a financial institution or insurer, or has a branded or similar title under any state's law. This does not affect emission warranties.

POSSIBLE CAUSE

Based on certain driving patterns and environmental factors, the DTC's stated above may set or whirling noise may occur.

CUSTOMER INFORMATION:The information in this bulletin is intended for use only by skilled technicians who have the proper tools, equipment, and training to correctly and safely maintain your vehicle. These procedures should not be attempted by "do-it-yourselfers," and you should not assume this bulletin applies to your vehicle, or that your vehicle has the condition described. To determine whether this information applies, contact an authorized Honda automobile dealer.

CORRECTIVE ACTION

If misfire (P0300, P0301, P0302, P0303, P0304) or fuel system too rich (P0172) DTCs are set, do REPAIR PROCEDURE A. If there is a whirling noise coming from the engine compartment, do REPAIR PROCEDURE B.

In some cases, misfire DTCs may return. If that happens, go to SPARK PLUG INSPECTION PROCEDURE.

WARRANTY CLAIM INFORMATION

NOTES

- DTC is required with claim submission.
- Since the templates below do not include oil, Non-Bulk oil and Bulk oil dealers must add the correct information into the Required Material section of your claim.

Operation Number	Description	Flat Rate Time	Defect Code	Symptom Code	Template ID	Failed Part Number
1245B6	Reset the maintenance minder. Update the PGM-FI and TCU software. Replace the oil, the A/C control unit , and do a throttle position reset and PCM idle learn procedure.	0.8 hr	03214	03217	A19032A	37805-5PA-A85

Operation Number	Description	Flat Rate Time	Defect Code	Symptom Code	Template ID	Failed Part Number
1245B5	Reset the maintenance minder. Update the PGM-FI and TCU software. Replace the oil, and do the throttle position reset and PCM idle learn procedure. (A/C control unit replacement not necessary.)	0.6 hr	03214	03217	A19032B	37805-5PA-A85

NOTE

Use the following templates if the spark plugs were also replaced.

Operation Number	Description	Flat Rate Time	Defect Code	Symptom Code	Template ID	Failed Part Number
1245B6	Reset the maintenance minder. Update the PGM-FI and TCU software. Replace the oil, the A/C control unit , and do a throttle position reset and PCM idle learn procedure.	0.8 hr	03214	03217	A19032C	37805-5PA-A85
A	Replace spark plugs. (Inspection or replacement)	0.3 hr				

Since the templates below do not include oil, Non-Bulk oil and Bulk oil dealers must add the correct information into the Required Material section of your claim.

Operation Number	Description	Flat Rate Time	Defect Code	Symptom Code	Template ID	Failed Part Number
1245B5	Reset the maintenance minder. Update the PGM-FI and TCU software. Replace the oil, and do the throttle position reset and PCM idle learn procedure. (A/C control unit replacement not necessary.)	0.6 hr	03214	03217	A19032D	37805-5PA-A85
A	Replace spark plugs. (Inspection or replacement)	0.3 hr				

Operation Number	Description	Flat Rate Time	Defect Code	Symptom Code	Template ID	Failed Part Number
1175A5	Replace spark plugs. (Inspection or replacement) (Admin Included)	0.5 hr	6D700	A4B00	A19032E	12290-5PA-A01

NOTE

Use the following template if the **camshafts** were only inspected.

Operation Number	Description	Flat Rate Time	Defect Code	Symptom Code	Template ID	Failed Part Number
1105C2	Remove valve cover and inspect camshafts. (No replacement required.)	0.7 hr	6D700	A4B00	A19032F	37805-5PA-A85

NOTE

Use the following template if the **camshafts** and **rocker arm assembly** were also replaced.

Operation Number	Description	Flat Rate Time	Defect Code	Symptom Code	Template ID	Failed Part Number
1105C2	Remove valve cover and inspect camshafts.	0.7 hr	6D700	A4B00	A19032G	37805-5PA-A85
A	Replace camshafts and rocker arm assembly. (Pre-approval needed, see iN parts catalog for ordering.)	5.1 hr				

Skill Level: Repair Technician

PARTS INFORMATION

Part Name	Part Number	Quantity
Drain Plug Washer (14 mm)	94109-14000	1
Auto Air Conditioner CPU Assembly (A/C Control Unit)	79600-TLA-A62	1

Part Name	Part Number	Quantity
Spark Plugs	12290-5PA-A01	4

REQUIRED MATERIAL

NOTE

For Non-Bulk oil and Bulk oil dealers, add the correct information into the Required Material section of your claim.

Part Name	Part Number	Quantity
0W-20 (Non-Bulk Oil Participants) (quarts)	08798-9063	4
0W-20 (Bulk Oil Participants) (gallons)	FS020-BAS-N0L	1

SOFTWARE INFORMATION

NOTE

Unnecessary or incorrect repairs resulting from a failure to update the i-HDS are not covered under warranty.

i-HDS Software Version: **1.004.064 or later**

J2534 Software Information:

- PC Application Version **1.1.0.6 or later**
- Database update **12-MAR-2019 or later**

Before beginning the repair, make sure that both the i-HDS and J2534 software are updated as listed above.

For more information about updating the i-HDS, the MVCI, and vehicle systems, refer to Service Bulletin 01-023, *Updating Control Units/Modules*.

Year/Model	Software System	Program ID (or later)	Program P/N (or later)
2017 CR-V (2WD)	PGM-FI	PA3060	37805-5PA-306
2017 CR-V (AWD)	PGM-FI	PA3080	37805-5PA-308
2018 CR-V (2WD)	PGM-FI	PAA690	37805-5PA-A69
2018 CR-V (AWD)	PGM-FI	PAA890	37805-5PA-A89
2017-18 CR-V (2WD)	TCM	RHA040	28101-5RH-A04
2017-18 CR-V (AWD)	TCM	RGA040	28101-5RG-A04

REPAIR PROCEDURE A

If misfire or fuel system too rich DTCs are set, follow the procedure below.

1. Reset maintenance minder main code A. Refer to the service information.
2. Drain and refill the engine oil (3.4 quarts). Do not replace the oil filter.
3. Connect the i-HDS and click on the **Body Electrical**. From there, select **HVAC** and open **Data List/Snapshot** to check if the A/C control unit has been replaced. One of three options will appear; **Not Complete**, **Completed**, or **Not Applicable**.
 - If it reads **Completed** or **Not Applicable**, skip to step 5.
 - If it reads **Not Complete**, go to step 4.
4. Replace the A/C control unit.
 - 4.1. Remove the passenger's dashboard side lid and the dashboard undercover.

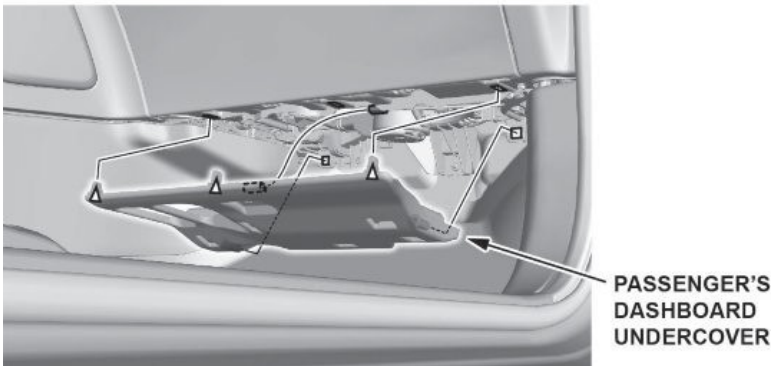
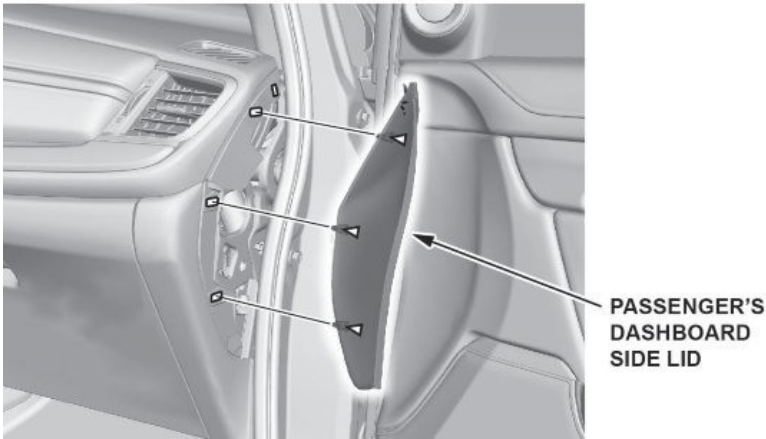

4.2. Remove the glove box.

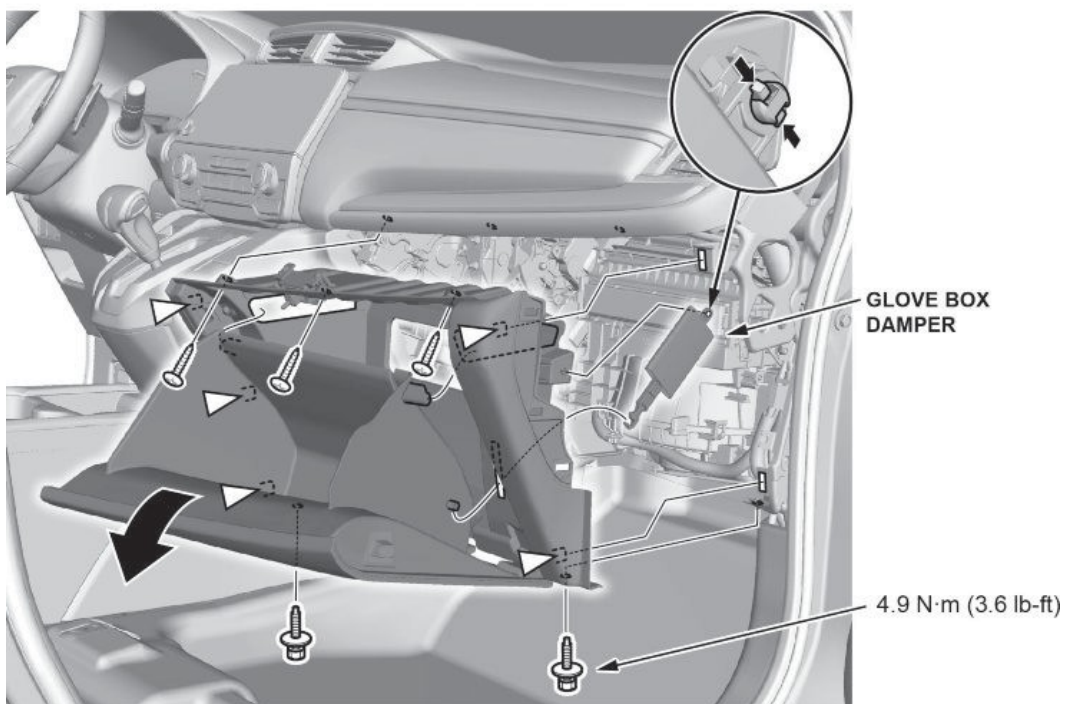

4.3. Remove the A/C control unit and replace with the new unit.

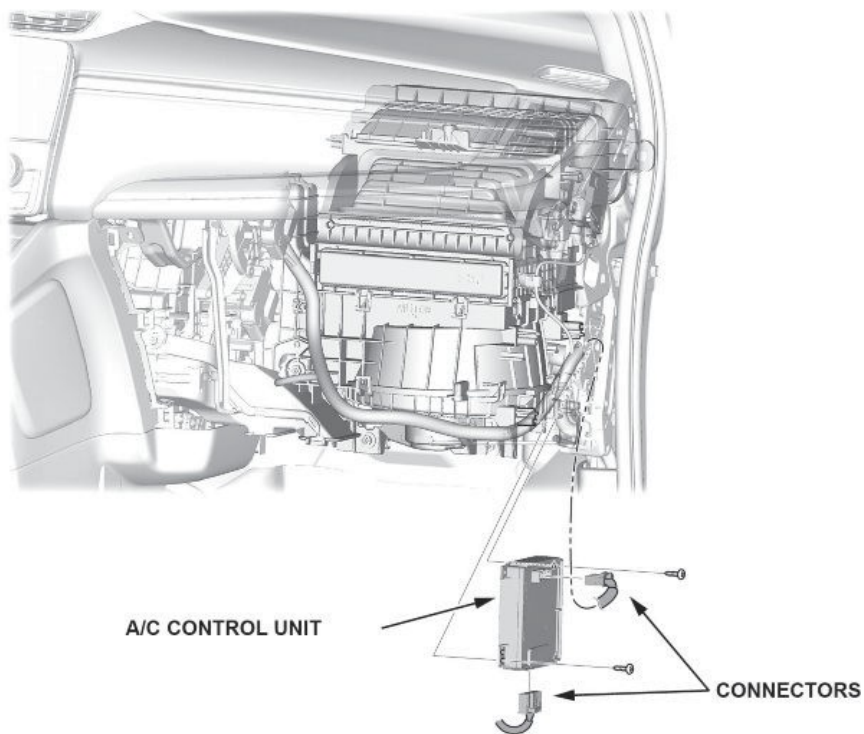

4.4. Install all parts in reverse order.

4.5. Run the self-diagnostics procedure with the i-HDS to make sure there are no problems in the system and clear any HVAC system DTCs that might appear.

5. With the i-HDS, check to see if the PGM-FI and TCM software has been updated by using the J2534 rewriting application.
 - If they are up to date, the procedure is complete.
 - If not, go to step 6.
6. Update the PGM-FI and TCM software using the i-HDS J2534 rewrite software with the MVCI or DST-i. Refer to Service Bulletin 01-023, *Updating Control Units/Modules*.

NOTES

- Connect a fully charged jumper battery and leave it connected during the entire procedure to maintain steady voltage.
 - Never turn the ignition to OFF or ACCESSORY during the update. If there is a problem with the update, leave the ignition turned to ON.
 - To prevent control unit damage, do not operate anything electrical (headlights, audio system, brakes, A/C power windows, door locks, etc.) during the update.
 - Do not use the MongoosePro VCI tool.
7. Reset the throttle position learned values by referencing the throttle body removal and installation in the service information, then do the PCM idle learn procedure. Refer to service information for additional instructions.

NOTE

For more information on the PCM idle learn procedure, see the *Tech2Tech*[®] video, "A Look at PCM Idle Learn".

SPARK PLUG INSPECTION PROCEDURE

1. In some cases, the DTCs may return. If this happens, inspect the spark plugs.



- If the spark plugs are OK, the procedure is complete. Continue with normal troubleshooting.
 - If the spark plugs are fouled, go to step 2.
2. Replace the spark plugs per service information and check for stored DTCs.

NOTE

Make sure to write down the stored DTCs on the R.O.

- If the applicable DTCs do not return, the procedure is complete.
- If the applicable DTCs return, this bulletin does not apply. Continue with normal troubleshooting.

REPAIR PROCEDURE B

If there is a whirling noise coming from the engine, follow the procedure below.

1. Warm up the engine by increasing the engine speed to **3,000 rpm** for two fan cycles.
2. After the warm-up procedure is completed, let the car return to idle for **10 seconds**.
3. After **10 seconds**, slowly increase the engine speed up to **3500 rpm** (this should take at least **20 seconds**).
4. Once the engine speed reaches **3500 rpm**, release the accelerator pedal and let the engine speed return to idle.
5. With the hood closed and inside the cabin, compare the audio file [here](#) to the noise heard.
 - If the noise is similar, continue to step 6.
 - If the noise is not similar, this bulletin does not apply. Continue with normal system troubleshooting.
6. Remove the cylinder head cover. See service information for additional instructions.
7. Compare the appearance of the camshaft lobes to the photo below.

 **GOOD**



 **NO GOOD**



The cam surface has ridges and a "cloudy" appearance.

- If the camshafts appear similar to the no good photo, go to step 8.
 - If the camshafts appear similar to the good photo, this bulletin does not apply. Continue with normal system troubleshooting.
8. Take a photo of the cam lobe, then follow the directions in the parts catalog when ordering the necessary parts.

NOTE

Please send photos of failed camshafts to PART_RELEASE@AHM.HONDA.COM to receive approval and release parts.

The following instructions are for replacement of the intake and exhaust camshafts and all rocker arm assemblies. This is only if you have been approved by following the instructions in the parts catalog.

1. Relieve the fuel pressure and remove the high pressure fuel pump. Refer to the service information for additional instructions.
2. Set the crankshaft to top dead center (TDC) for No. 1 cylinder. Refer to step 4 of the Camshaft Timing Inspection in the service information.
3. Mark the timing chain at the punch marks on the exhaust and intake camshaft sprocket and VTC actuator as seen below.

Mark the cam chain at the punch marks on the sprocket.

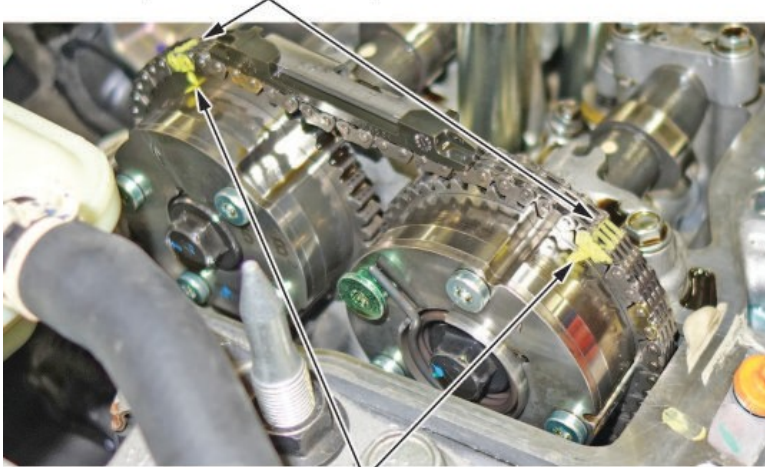

PUNCH MARKS

4. Raise the vehicle on a lift.
5. Remove the right front wheel and the engine undercover.
6. Remove the cam chain auto-tensioner (chain case) cover.
7. Slightly rotate the crankshaft counterclockwise to compress the auto-tensioner. Line up the hole in the lock and auto-tensioner, then insert a 1.2 mm diameter lock pin.

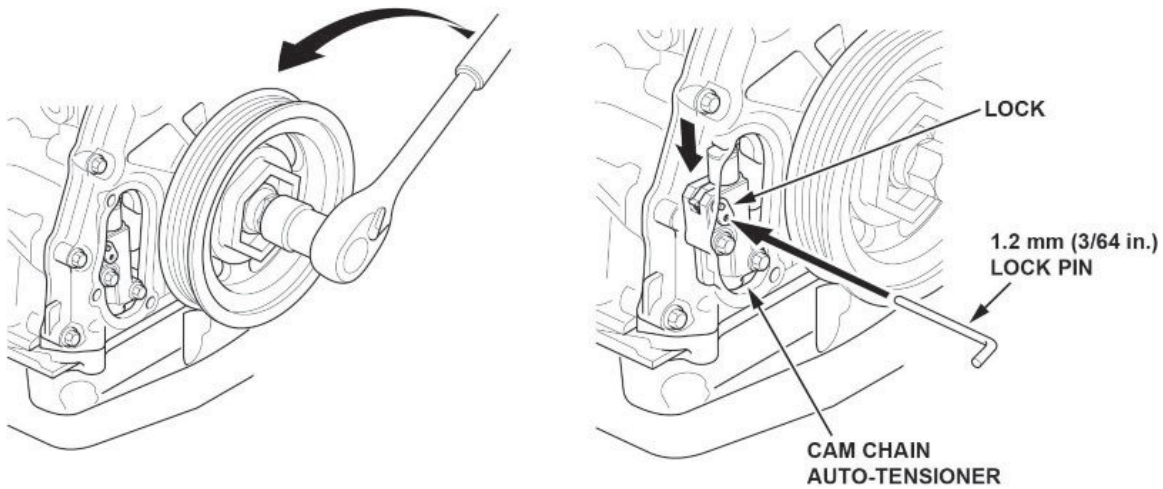

8. Rotate the crankshaft clockwise back to TDC on the No. 1 cylinder to secure the lock pin in place.
9. Remove the camshaft chain auto-tensioner with the lock pin inserted.

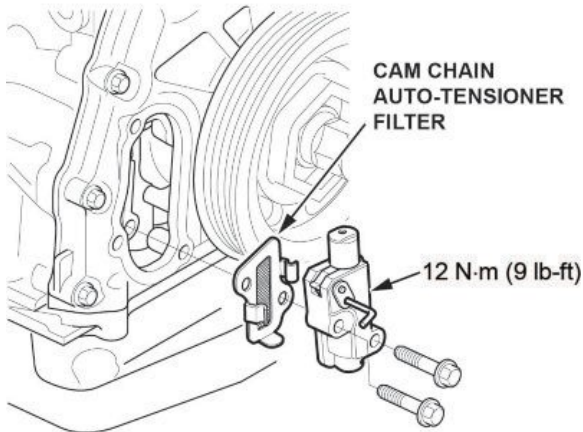

10. Lower the vehicle.
11. Loosen the locknuts and adjusting screws.

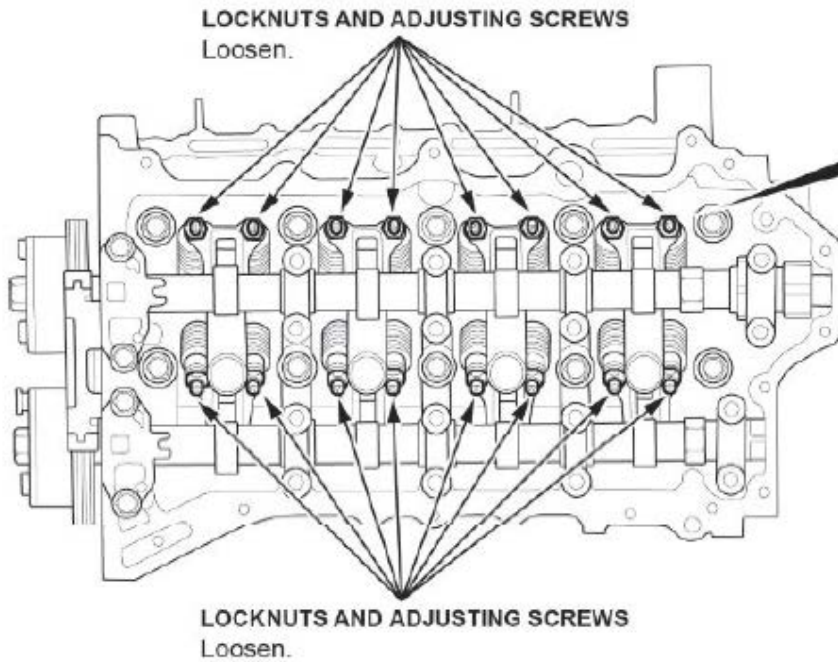

12. Remove the high pressure fuel pump base.

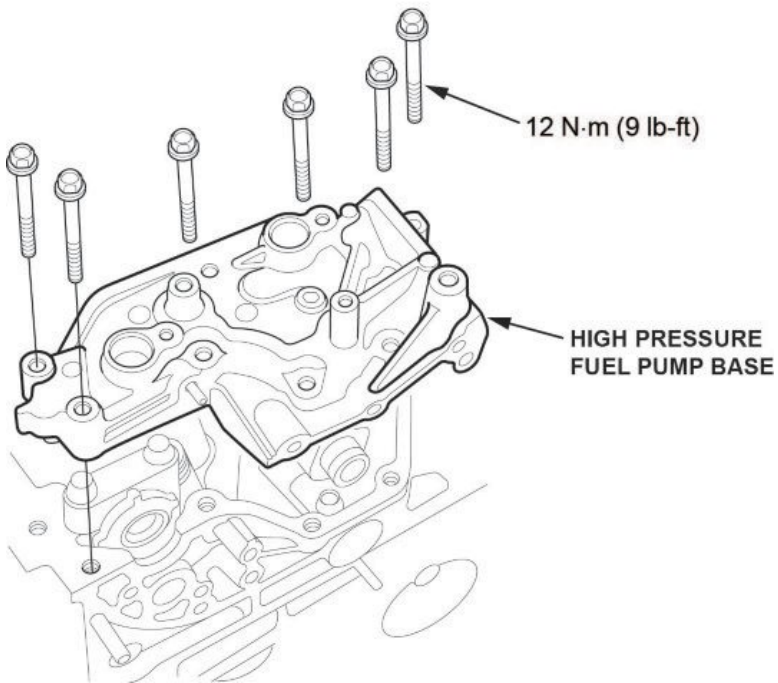

13. Remove the camshaft holder bolts, then remove the camshaft holders. To prevent damaging the camshafts, loosen the bolts in sequence, two turns at a time.

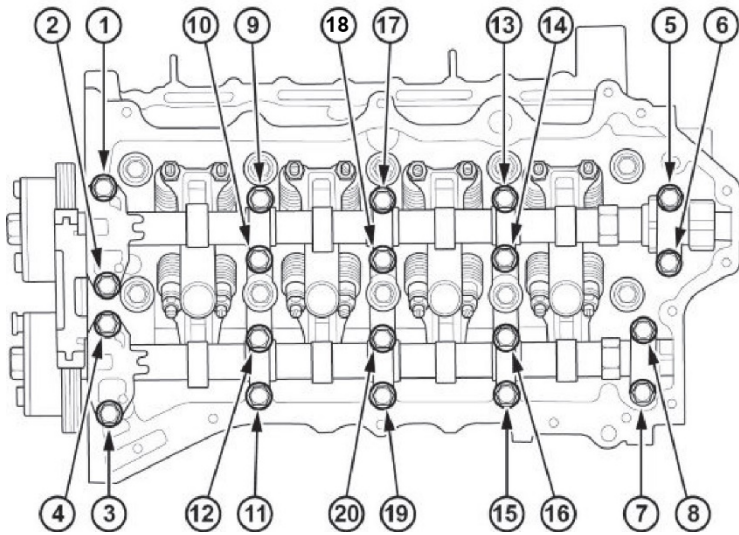

14. Lift up the cam chain, then carefully remove the intake camshaft followed by the exhaust camshaft.

NOTE

You must maintain tension on the cam chain while you do this.

Lift up the cam chain and carefully slip the camshaft out.



15. Use a bungee cord to hold tension on the cam chain while you are replacing the camshafts.

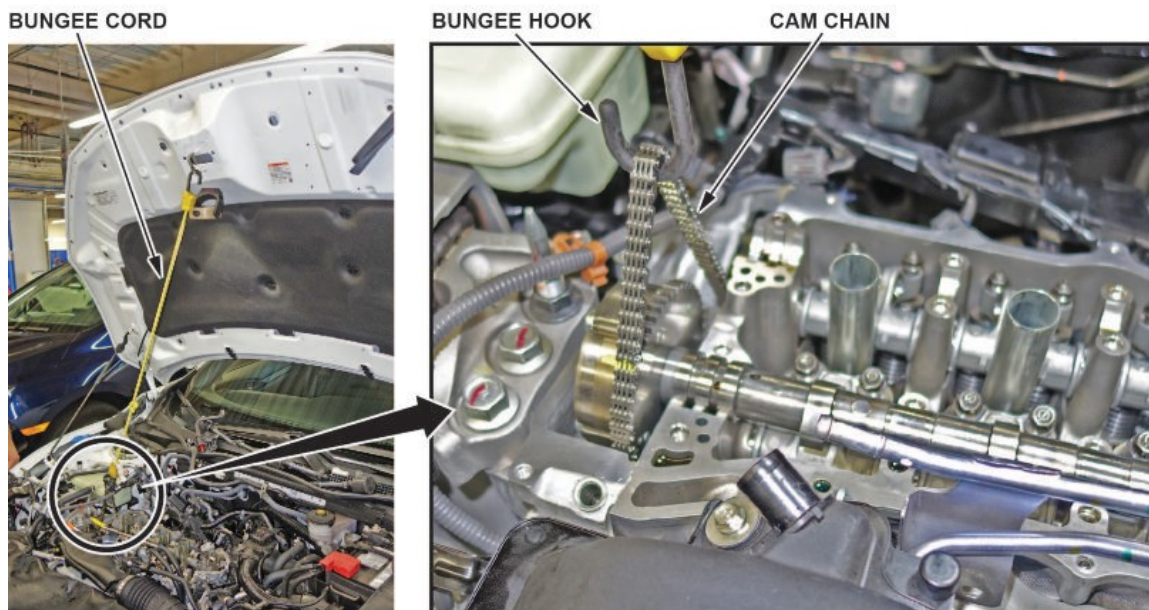

16. When removing the camshaft holders, cam chain guide, and intake and exhaust camshaft, make sure to place them in order of installation on a clean, padded workbench.

17. Remove the rocker arm assembly, and install the new set. Refer to the service information for additional instructions.

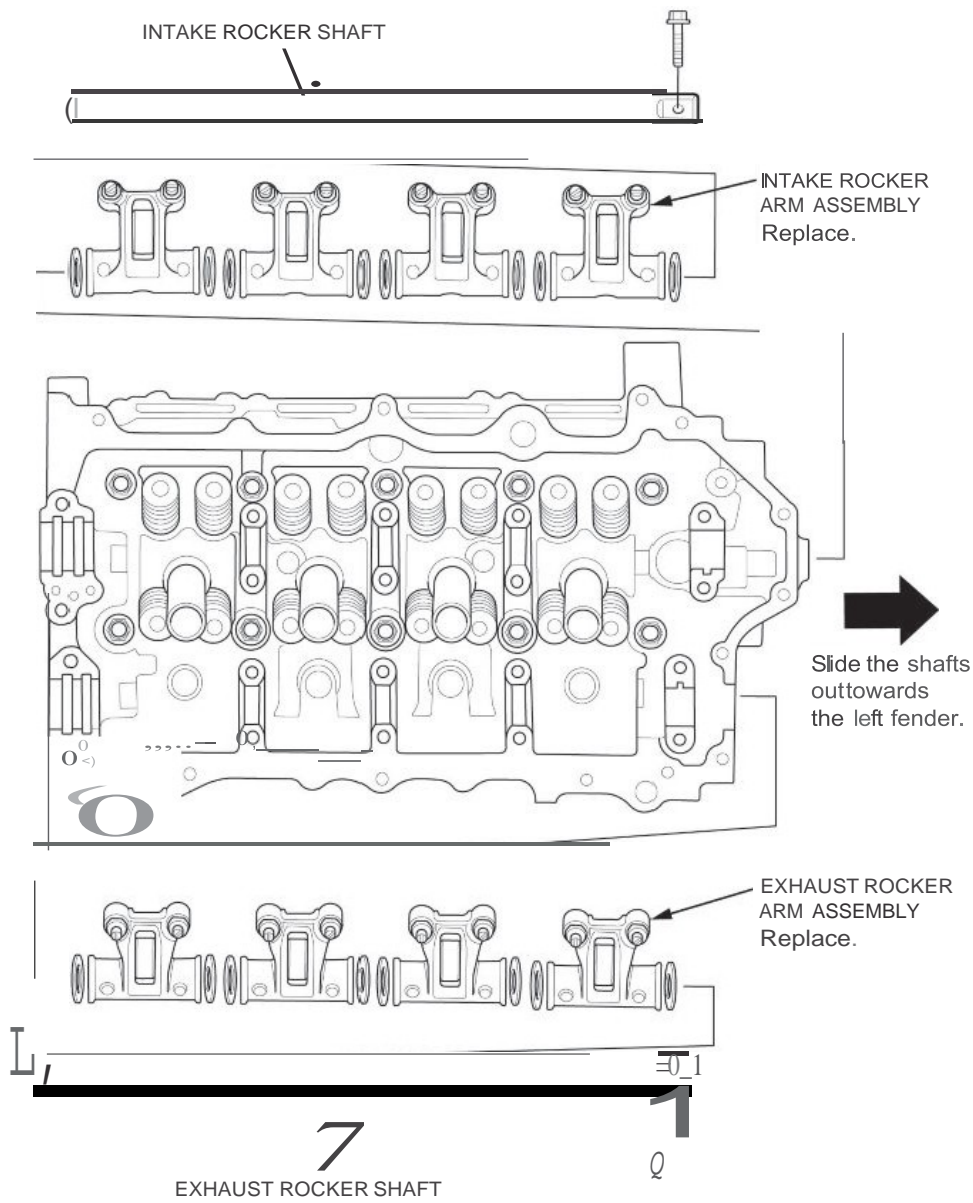

18. With the camshafts out of the engine, hold them with an open-end wrench and loosen the VTC actuator mounting bolts on both camshafts.

19. Install the VTC actuators on the new camshafts.

NOTE

You may need an assistant to help you with this procedure.

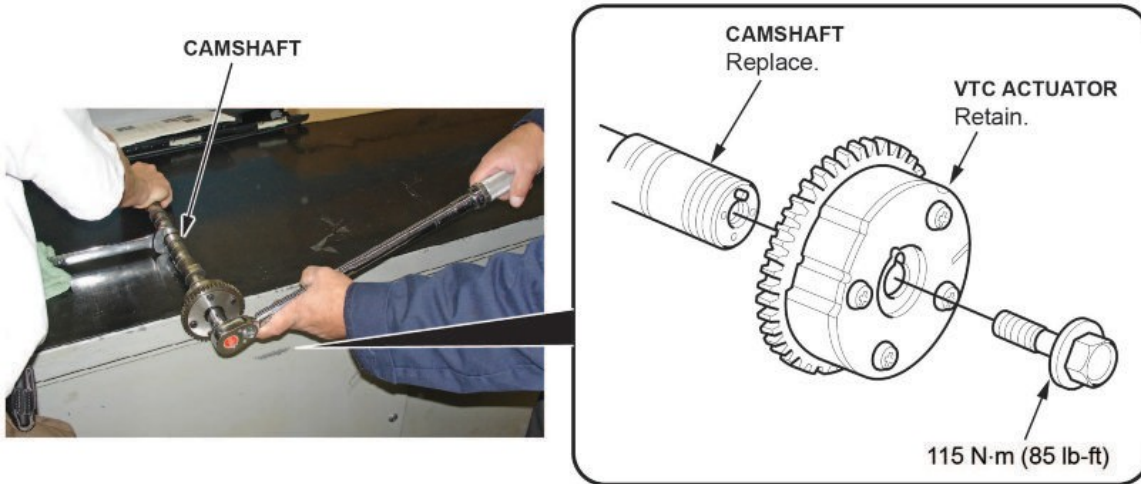

20. Apply fresh engine oil to the new camshafts, and install.

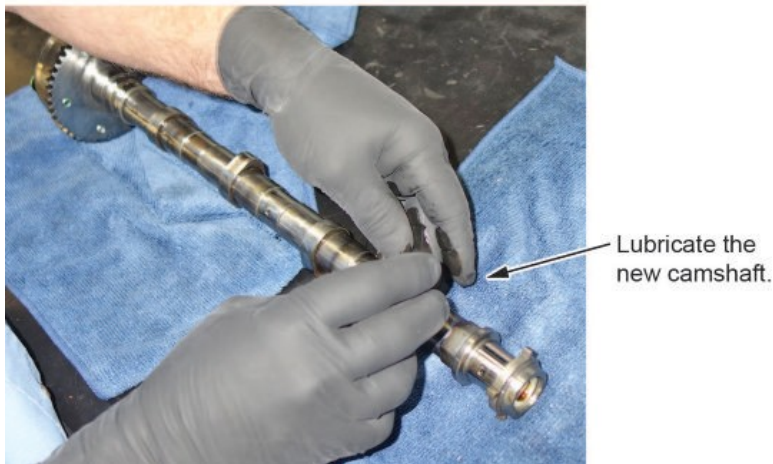

21. When installing the new camshafts, ensure the previously made marks on the VTC actuator and cam chain line up.



As the camshaft is installed, line up the marks made in step 3.

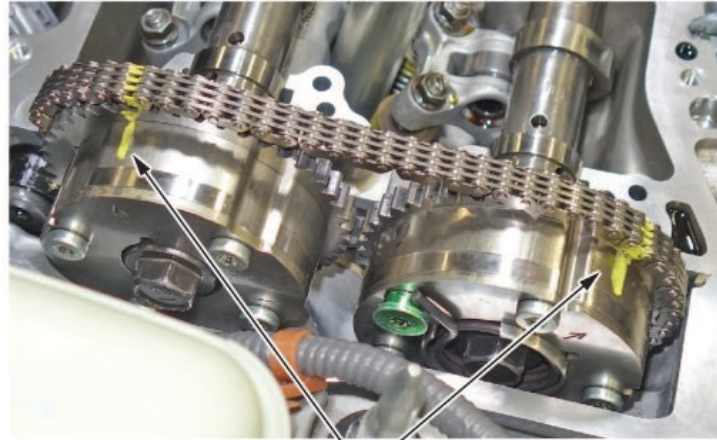

MARKS

22. Install the camshaft holders and the cam chain guide, then torque them to specification.

23. Install the camshaft chain tensioner and release the lock pin.

24. Install the new cam chain auto-tensioner (chain case) cover.

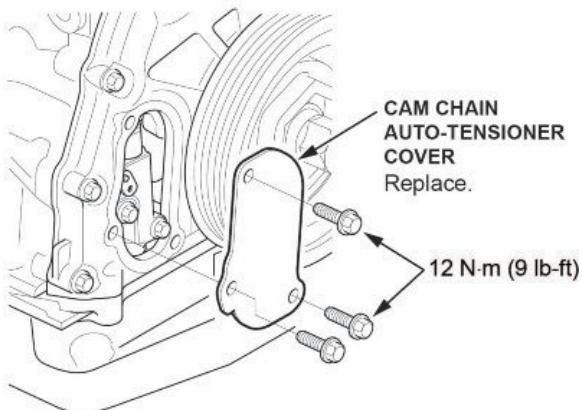

25. To check the camshaft timing, rotate the crankshaft in the direction of engine rotation (clockwise) two full turns, then stop at the TDC mark. Refer to step 4 of the Camshaft Timing Inspection in the service information.

26. Do a valve adjustment.

27. Install the high pressure fuel pump base and new camshaft holder cover. Refer to step 07 of the installation section of the Cylinder Head Removal and Installation (1.5L Engine) in the service information.

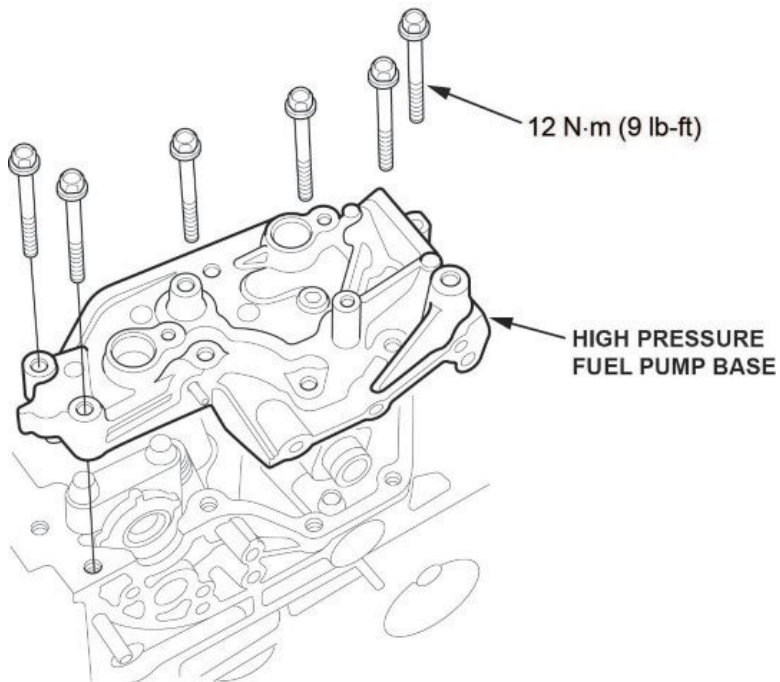

28. Install the cylinder head cover. Refer to the service information for additional instructions.
29. Install the high pressure fuel pump with the new o-ring and fuel joint pipe. Refer to the service information for additional information.
30. Install the engine undercover and any other remaining parts.
31. During the first start up, check for DTCs set or abnormal noises. Refer to service information for additional instructions.
32. Connect the i-HDS and click on the **Body Electrical**. From there, select **HVAC** and open **Data List/Snapshot** to check if the A/C control unit has been replaced. One of three options will appear: **Not Complete**, **Completed**, or **Not Applicable**.
- If it reads **Completed** or **Not Applicable**, skip to step 34.
 - If it reads **Not Complete**, go to step 33.

33. Replace the A/C control unit.

33.1. Remove the dashboard side lid and the dashboard undercover.

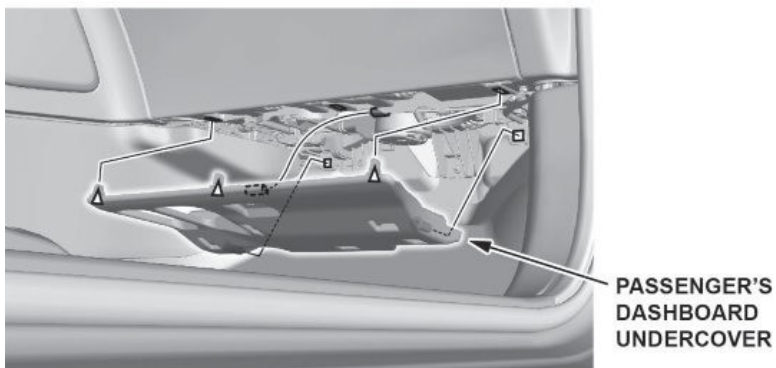
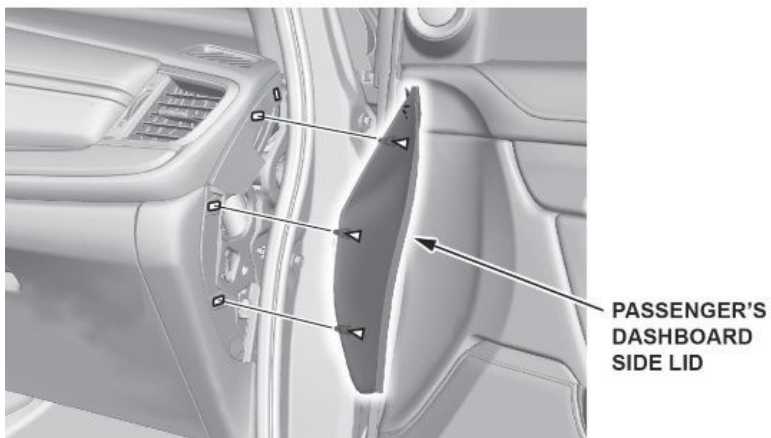

33.2. Remove the glove box.

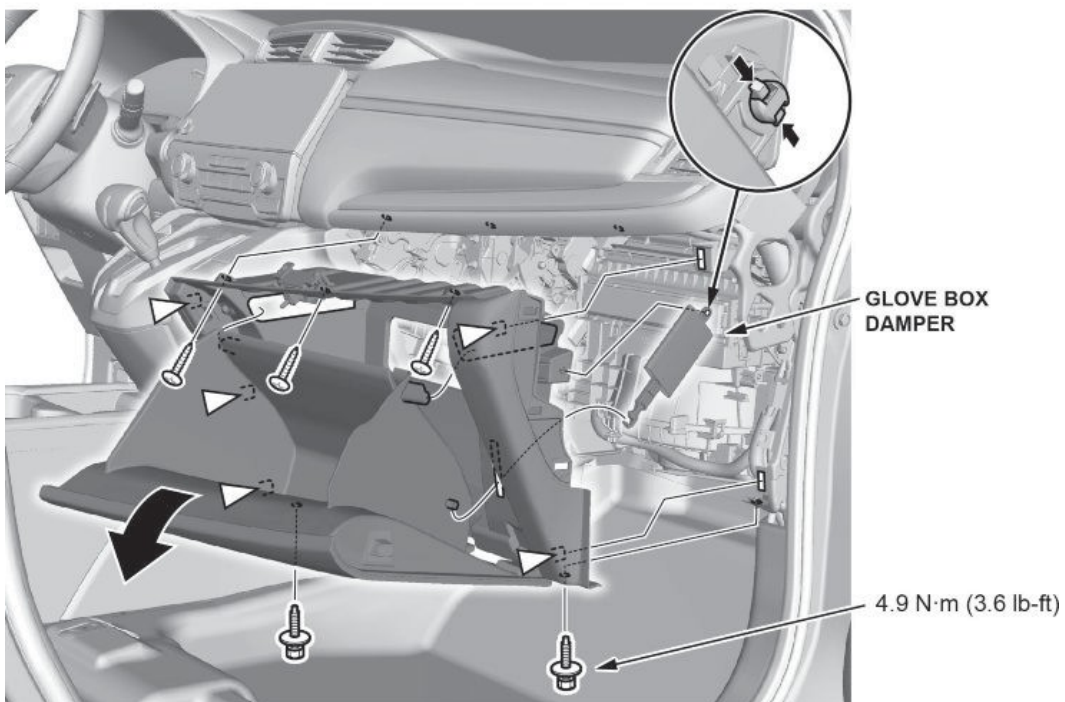

33.3. Remove the A/C control unit and replace with the new unit.

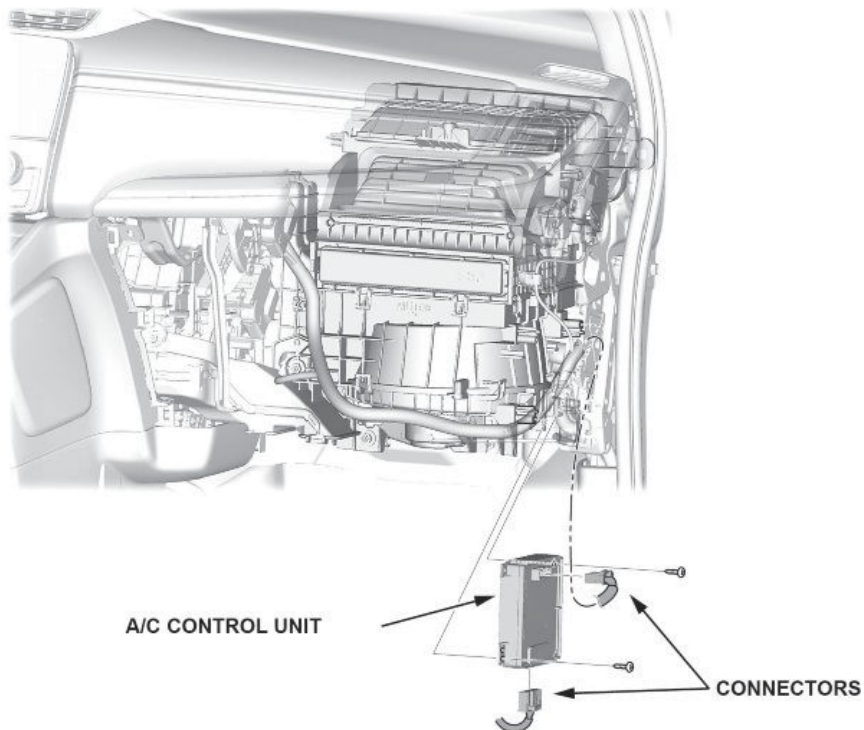

33.4. Run the self-diagnostics procedure with the i-HDS to make sure there are no problems in the system and clear any HVAC system DTCs that might appear.

34. Reset maintenance minder main code A. Refer to the service information.

35. Drain and refill the engine oil (3.4 quarts). Do not replace the oil filter.

36. With the i-HDS, check to see if the PGM-FI and TCM software has been updated by using the J2534 rewrite application.

- If updated, the procedure is complete.
- If not, continue with step 37.

37. Update the PGM-FI and TCM software using the i-HDS J2534 rewrite software with the MVCI or DST-i. Refer to Service Bulletin 01-023, *Updating Control Units/Modules*.

NOTES

- Connect a fully charged jumper battery and leave it connected during the entire procedure to maintain steady voltage.
 - Never turn the ignition to OFF or ACCESSORY during the update. If there is a problem with the update, leave the ignition turned to ON.
 - To prevent control unit damage, do not operate anything electrical (headlights, audio system, brakes, A/C power windows, door locks, etc.) during the update.
 - Do not use the MongoosePro VCI tool.
38. Reset the throttle position learned values by referencing the throttle body removal and installation in the service information, then do the PCM idle learn procedure. Refer to service information for additional instructions.

NOTE

For more information on the PCM idle learn procedure, see the *Tech2Tech*[®] video, "A Look at PCM Idle Learn".