

**TECHNICAL INSTRUCTIONS**

**FOR**

**CUSTOMER SUPPORT PROGRAM 22TE09**

**HV FLOOR UNDER WIRE HARNESS AND REAR TRACTION MOTOR CABLE  
CORROSION**

**CERTAIN 2022 MODEL YEAR NX450H+**

The repair quality of covered vehicles is extremely important to Lexus. All dealership technicians performing this recall are required to successfully complete the most current version of the E-Learning course "Safety Recall and Service Campaign Essentials". To ensure that all vehicles have the repair performed correctly; technicians performing this recall repair are required to complete the following course:

- LIC209A – EPV Repair

It is the dealership's responsibility to select technicians with the above certification level or greater to perform this recall repair. Carefully review your resources, the technician's skill level, and ability before assigning technicians to this repair. It is important to consider technician days off and vacation schedules to ensure there are properly trained technicians available to perform this repair at all times.

## I. OPERATION FLOW CHART

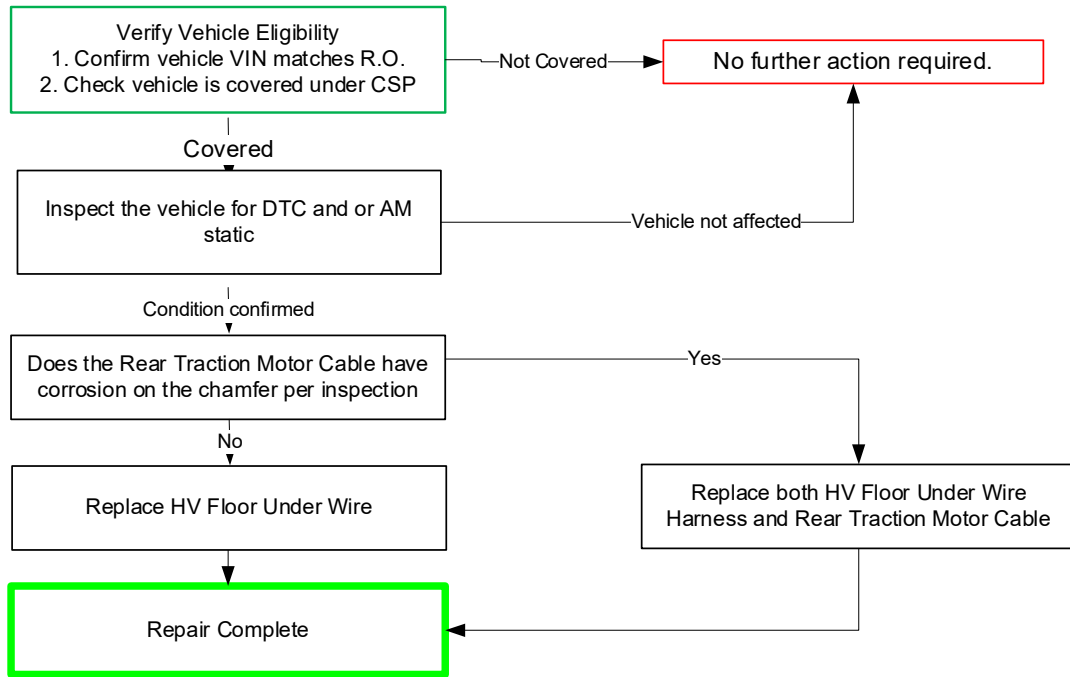

## II. BACKGROUND

Although the HV Floor Under Wire Harness and Rear Traction Motor Cable is covered by Lexus's New Vehicle Limited Warranty for 4 years or 50,000 miles (whichever comes first), we at Lexus care about the customers' ownership experience. Lexus is providing coverage for repairs related to excessive corrosion to the wire harness connections at the Rear Motor Generator. Excessive corrosion can cause AM Radio Static during certain drive cycles, or the vehicle may not start.

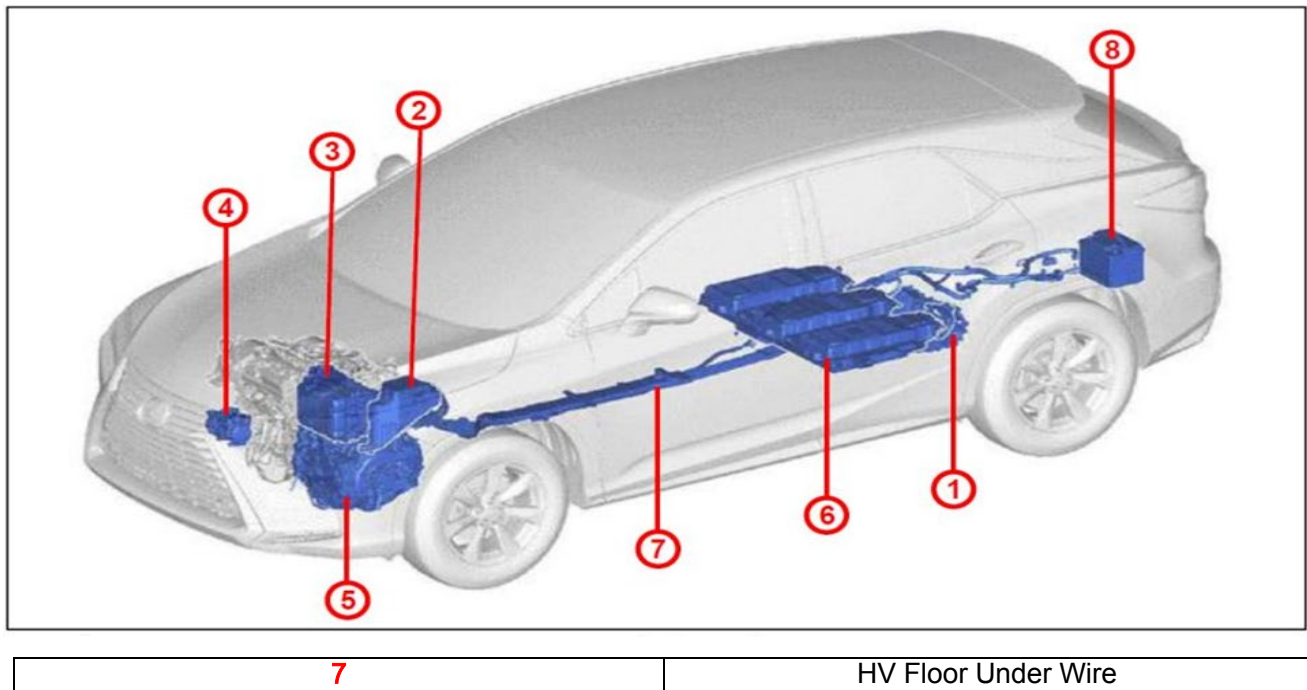

### III. IDENTIFICATION OF AFFECTED VEHICLES

- Check TIS to confirm the VIN is involved in this Customer Support Program
- **TMS warranty will not reimburse dealers for repairs conducted on vehicles that are not affected.**

### IV. PREPARATION

#### A. PARTS

**Dealers are not to order parts for stock.**

##### HV Floor Under Wire Harness Repair Parts

Part Number	Description	Qty
821H1- 78040	HV Floor Under Wire Harness	1
72693-06030	Rear Seat Cushion Hook Clips	2
90917-A6002	Gasket, Exhaust Pipe	1
17451-F0100	Gasket, Exhaust Pipe	1
17173-25020	Gasket, Exhaust Manifold to Head	1
90177-A0021	Nut, Lock	2
90105-A0369	Bolt, Flange	2
90068-14011	Ring, O, No. 3 for Liquid Tube	1
90099-14155	Ring, O, No. 9 for Discharge Tube	1

**Rear Traction Motor Cable Parts: Only requires replacement based on inspection s.**

Part Number	Description	Qty
G1149-42010	Rear Traction Motor Cable	1
G114D-47021	Cap Motor Cable Terminal	1
90105-A0420	Bolt, w Washer	2
90119-A0512	Bolt, W Washer	1

#### B. TOOLS & EQUIPMENT

- Techstream
- Basic Hand Tools
- Transmission Jack
- Torque wrench
- Screw Jack
- DVOM

**SST-** The following tools are essential service tools that all dealers are required to have.

Part Number	Part Description	Quantity
-	Insulated Tools	As needed
01413-00072 (Small)	Insulated Glove Set, Rubber With Leather Protectors*	1
01413-00073 (Medium)		
01413-00074 (Large)		

#### **CAUTION**

**ALWAYS inspect the insulated gloves before use for cracks, ruptures, tears, pinholes, or damage. Do NOT wear if damaged.**

### V. CONFIRM CONDITION EXISTS AND CABLE INSPECTION

- 1) Perform a health check and confirm if DTC P0AA649 OR P1C8049 are present

**YES** – Continue to Step 3

**NO** – Continue to Step 2

**For part release a screenshot is required of DTC from Techstream and the VIN must be in screenshot.**

- 2) Inspect the vehicle for AM static radio interference

- a) Ready on vehicle
- b) Change the radio to a known AM station.
- c) After the radio is on a known station, place the vehicle into Drive or Reverse while applying the brake.
- d) Return the vehicle to Park after 3 seconds.
- e) Repeat (c) and (d) 3 times.

When placing the vehicle into drive or reverse is AM static introduced each time placed into Drive or Reverse?

**YES** – Continue to Step 3

**NO** - This CSP does not apply. Please consult the repair manual and continue the diagnosis.

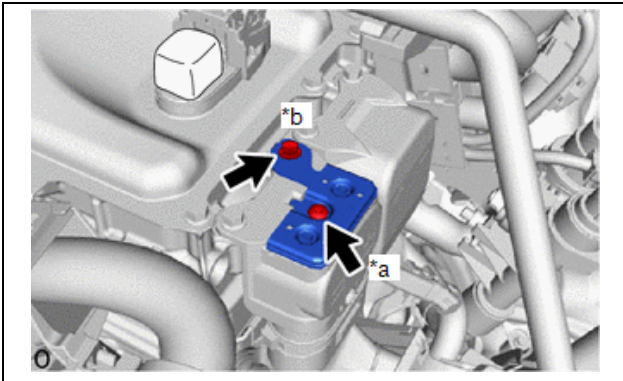

### 3) Disable High Voltage Circuit for Inspection

- a) Temporarily disconnect 12 v battery.
- b) Remove the hybrid service plug.
- c) Remove bolt (b) at the inverter as shown.
- d) Using a T25 "TORX" socket wrench, remove the bolt (a) and connector cover assembly from the inverter with converter assembly.

#### NOTICE:

- Do not touch the connector cover assembly waterproof seal.
- Do not allow any foreign matter or water to enter the inverter with converter assembly.

- e) Using a voltmeter, measure the voltage between the terminals of the 2-phase connectors.

**Standard Voltage: 0 V**

**NOTICE:** Do not allow any foreign matter or water to enter the inverter with converter assembly.

**HINT:** Use a measuring range of DC 750 V or more on the voltmeter.

#### CAUTION

Be sure to wear insulated gloves.

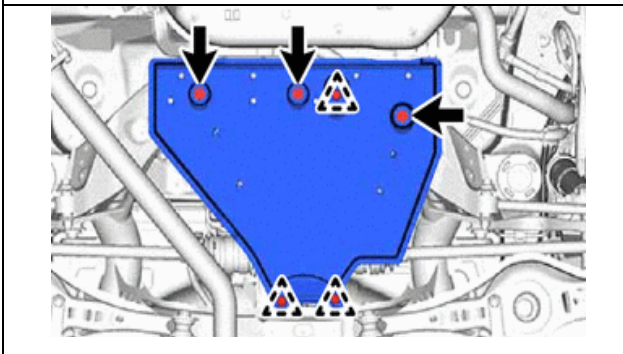
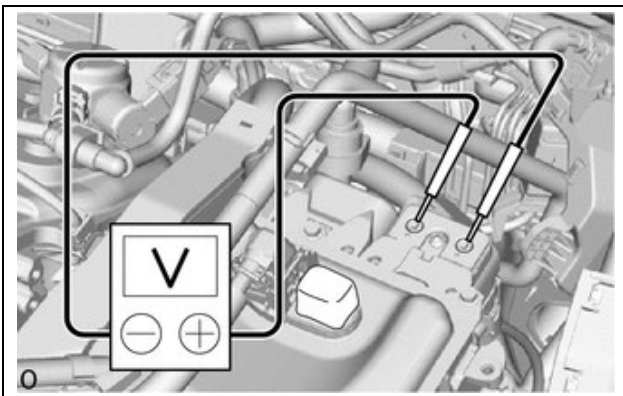

### 4) Remove No. 1 Floor Under Cover

- a) Remove the 3 bolts, 3 clips, and No. 1 floor under cover from the rear suspension member sub-assembly.

**Y6 connector under the vehicle at MGR**



- 5) **Inspect the Y6 connection for corrosion**  
f) Disconnect the Y6 connector at the MGR and inspect for corrosion, dirt, or debris.

**CAUTION**

Orange wire harnesses and connectors indicate high-voltage circuits. To prevent electric shock, always follow the procedure described in the repair manual to disable the high-voltage system.

To prevent electric shock, wear insulated gloves when working on wire harnesses and components of the high-voltage system.

**YES** – Continue to Section VI.

**For parts release take a photo of the connector housing with R.O. in the picture.**

**NO** - This CSP does not apply. Please consult the repair manual and continue the diagnosis.

6) **Inspect the connector housing of the MGR**

- a) Inspect the chamfer of the MGR connector housing for pitting and corrosion on the sealing surface. Corrosion in this area will cause the seal to leak. Are pitting and corrosion present?

**YES** – Rear Traction Motor Cable requires replacement continue to Section VI.

**Take a photo of the connector housing with R.O. in the picture for parts release.**

**NO** – Cable does NOT require replacement continue to Section VI.

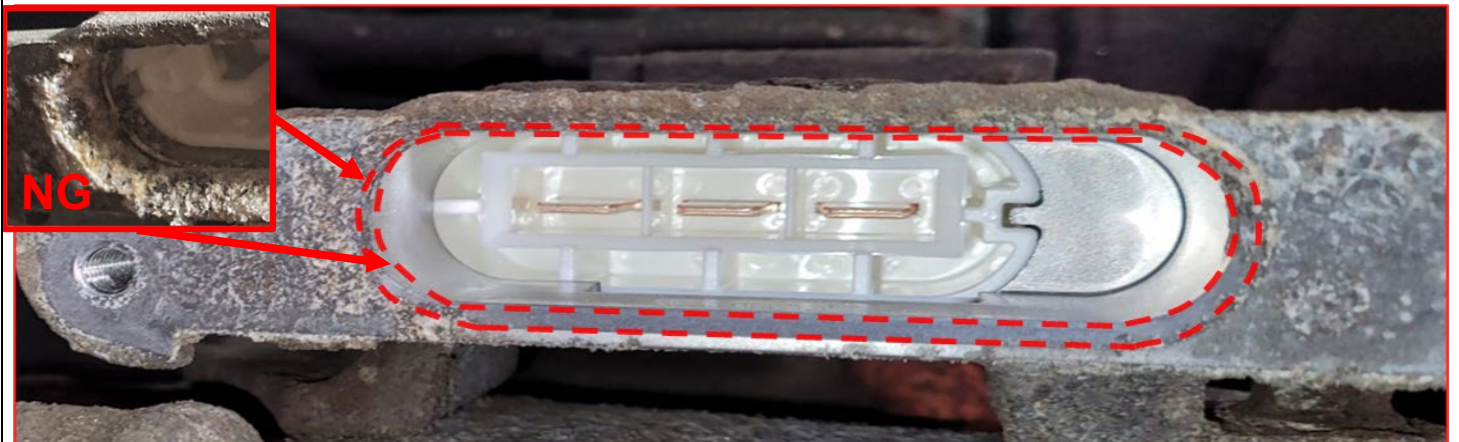

## VI. CABLE REMOVAL PROCEDURE

### A. HV FLOOR UNDER WIRE REMOVAL

1. Remove the HV Floor Under Wire following the repair manual procedure.

Refer to TIS, applicable model, and model year Repair Manual:

- [2022 NX450H+](#):

*“Engine/Hybrid System – Hybrid/Battery Control System – “Hybrid / Battery Control: Frame Wire: Removal”*

**B. REAR TRACTION MOTOR CABLE REMOVAL (if required, if not required skip to Section VII.B)**



1. Disconnect MGR Ground Plug/Sensor (if equipped)
  - a) Remove the bolt from the ground and bracket.

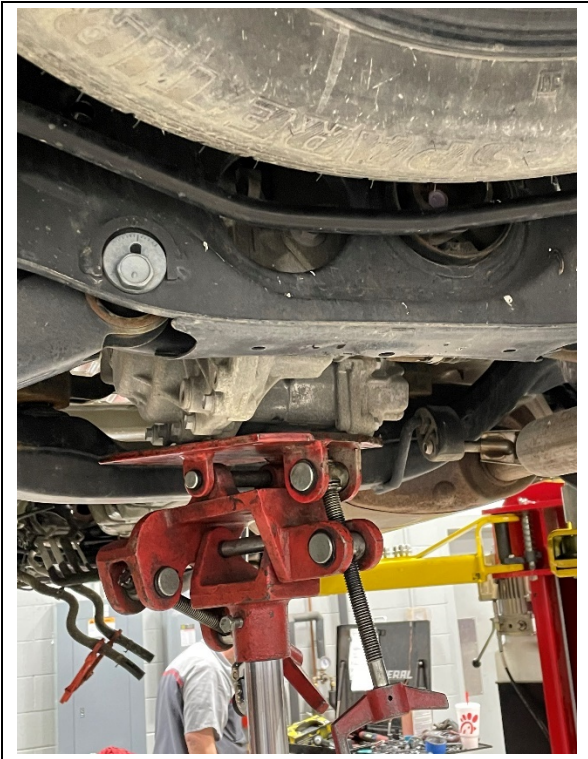

2. Place the transmission jack under MGR and secure it.

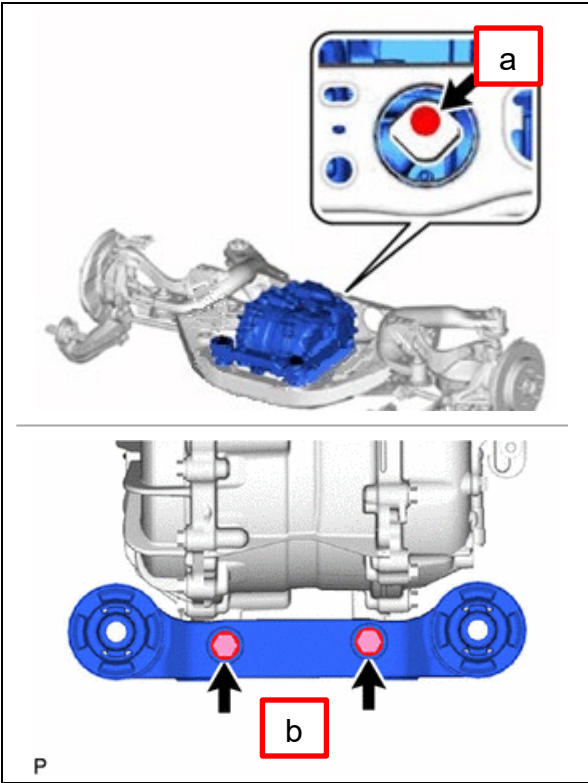

3. Remove MGR mounting bolts

- a) Remove the MGR rear mount bolt.
- b) Remove the front mount inner bolts (Do not remove outer bolts).
- c) Slowly tilt the MGR assembly 3 inches to gain clearance with the body. (Do not remove assembly).

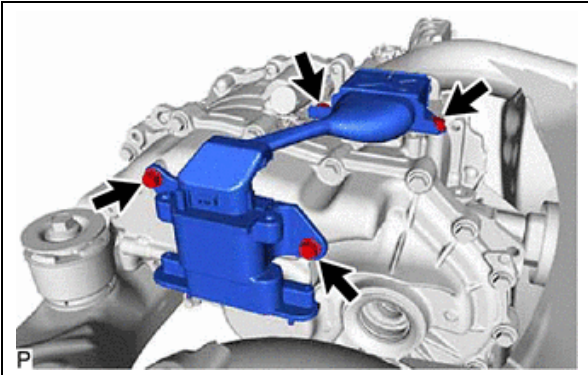

4. Remove the Rear Traction Motor Cable side mount bolts

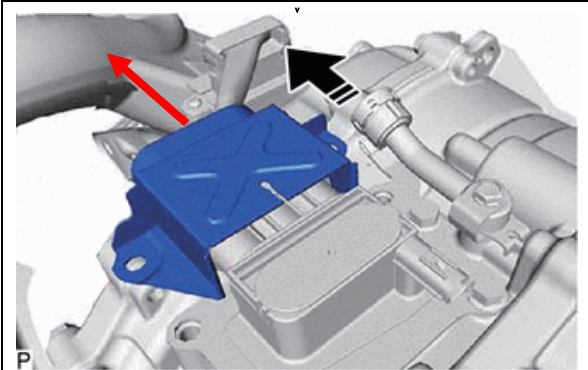

5. Remove Motor Cable Terminal Cap (Non-Reusable)

- a) Slide the cover on the top side of the rear traction motor cable.
- b) Clean the area with shop air and rag around the cover to avoid debris falling in.

**NOTICE:**

- Some vehicles may be extremely dirty in this area, ensure you clean thoroughly before removing the cover.

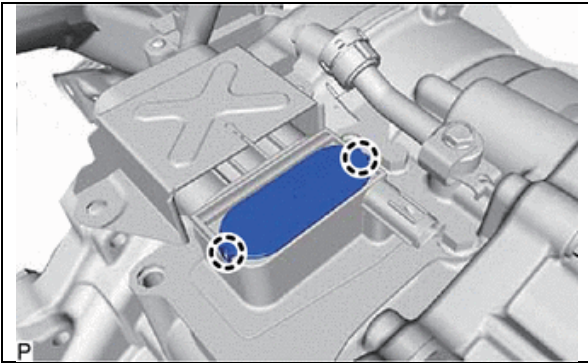

- c) Disengage the 2 claws to remove the motor cable terminal cap from the rear traction motor with transaxle assembly.

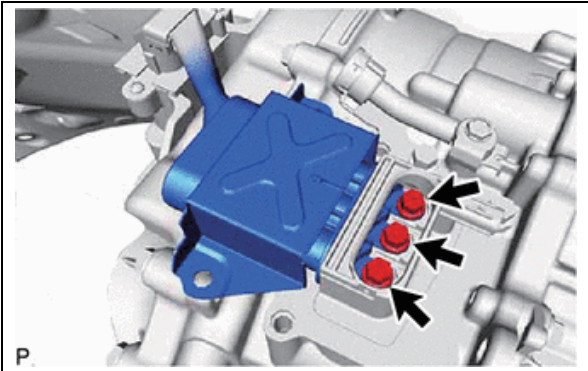

6. **Rear Traction Motor Cable**

- a) Remove Rear Traction Motor Cable High Voltage Mount Bolts.

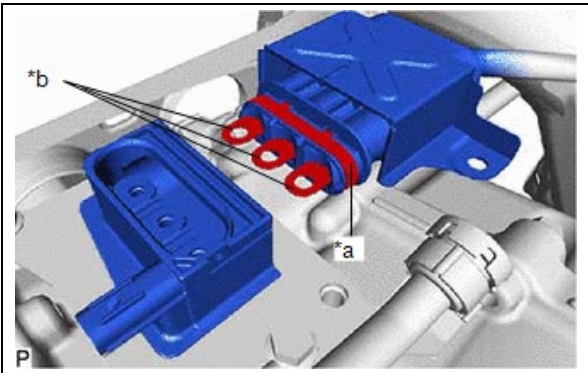

- b) Remove Rear Traction Motor Cable from MGR Assembly.

## VII. CABLE INSTALL PROCEDURE

### A. REAR TRACTION MOTOR CABLE INSTALLATION (if required, if not required skip to Section VII. B)

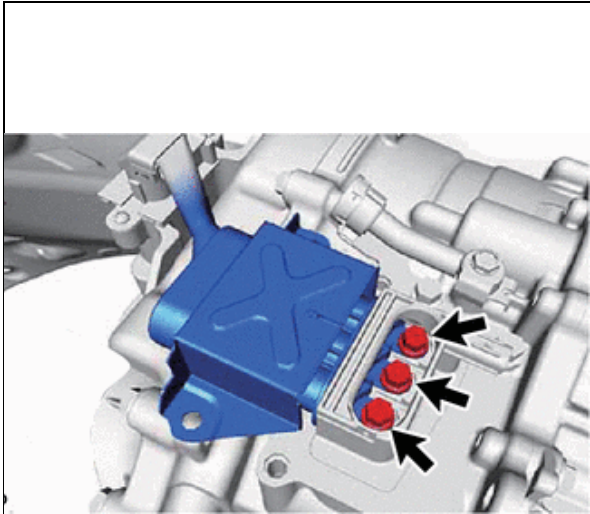

#### 1. Install the Rear Traction Motor Cable onto the MGR

- a) Clean the area around the terminal of the rear traction motor cable, and then blow air on the terminal to remove dust and other foreign matter.

##### NOTICE:

- Blowing air without cleaning first may cause dust and other foreign matter to enter the terminal.
- Dust or other foreign matter entering the terminal when installing the rear traction motor cable may cause a short or electrical leakage.

- b) Using an insulated tool, install the rear traction motor cable to the rear traction motor with transaxle assembly with the 3 bolts.

##### Torque:

10 N·m {102 kgf·cm, 7 ft·lbf}



**Torque is critical at this electrical connection. Ensure proper torque is applied to each bolt.**

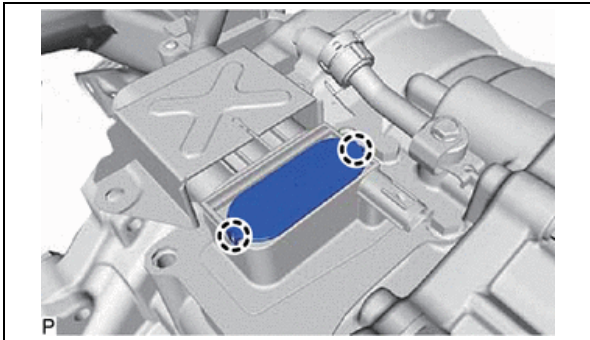

#### 2. Install the new motor cable terminal cap

- a) Engage the 2 claws to install a new motor cable terminal cap to the rear traction motor with transaxle assembly.

##### NOTICE:

- Do not pinch the O-ring.
- Check that the motor cable terminal cap is properly installed.

- b) Slide the cover on the top side of the rear traction motor cable.

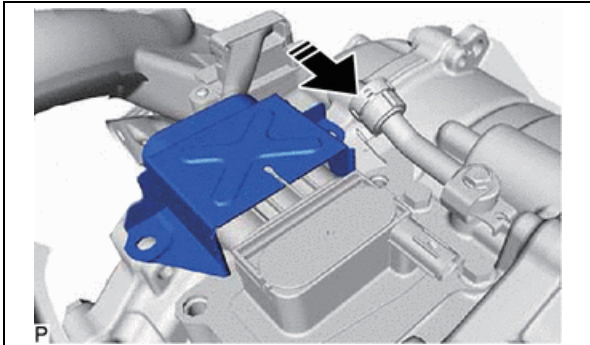

#### 3. Install the 4 bolts for the rear traction motor cable

##### Torque:

22 N·m {224 kgf·cm, 16 ft·lbf}

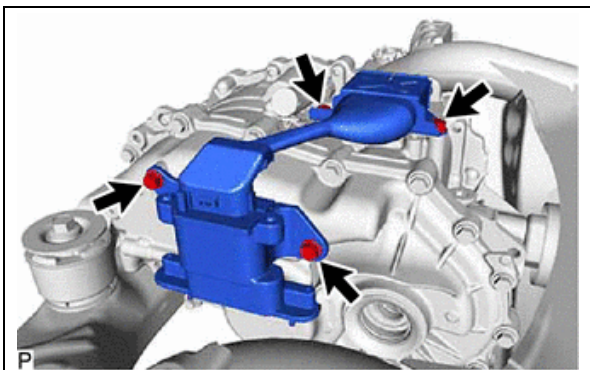

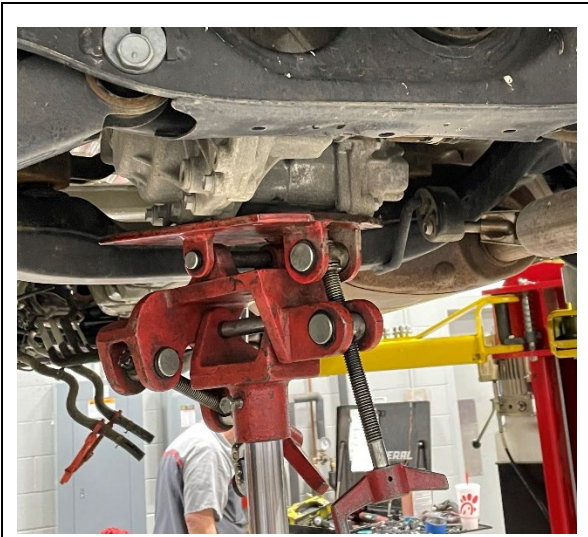

4. Raise the MGR with Transmission Jack

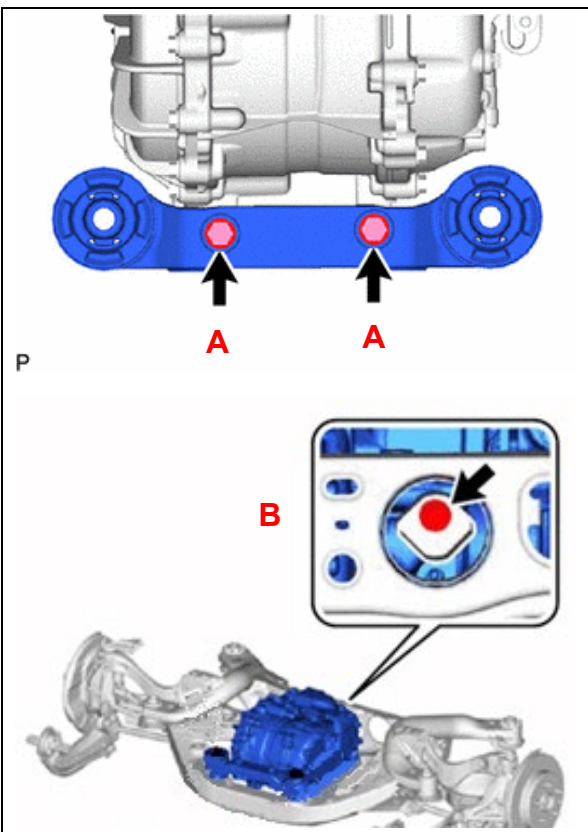

5. Reinstall the MGR mounting bolts

- a) Temporarily install bolts (A) and (B).
- b) Torque bolts to specification starting with (A) and then moving to (B).

Torque:

- for bolts A :  
55 N·m {561 kgf·cm, 41 ft·lbf}
- for bolt B :  
130 N·m {1326 kgf·cm, 96 ft·lbf}

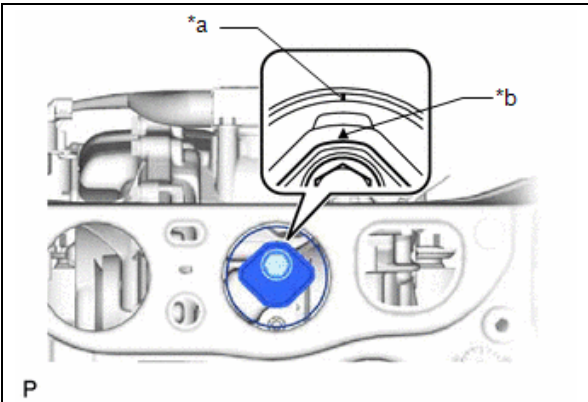

- c) After tightening bolt (B), make sure the inner cylinder mark (a) and rubber part mark (b) are positioned as shown.

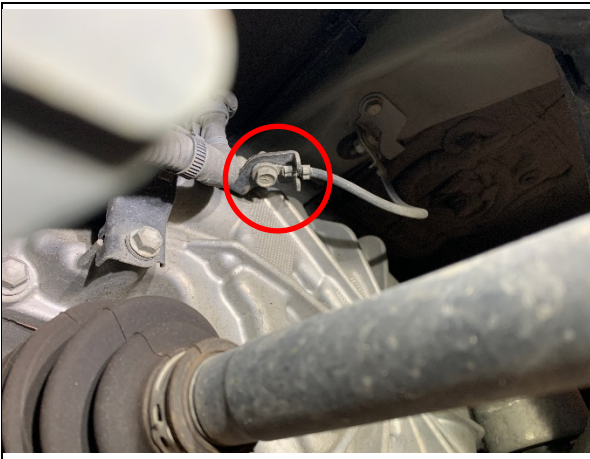

6. Reinstall MGR Ground Plug/Sensor

- a) Reinstall ground wire to bracket with bolt and torque to specification.

Torque:

10 N·m {102 kgf·cm, 7 ft·lb}

B. INSTALL THE HV FLOOR UNDER WIRE.

1. Install the HV Floor Under Wire following the repair manual procedure

Refer to TIS, applicable model, and model year Repair Manual:

- [2022](#) NX450H+:

*Engine/Hybrid System – Hybrid/Battery Control System – “Hybrid / Battery Control: Frame Wire: Installation”*

**NOTICE:** When installing the new HV Floor Under Harness ensure to leave the cover on the wire harness for the inverter connector to protect it during the installation and routing.



2. Using Techstream, run a Health Check to verify DTCs P0AA649 and/or P1C8049 are no longer present
3. Test-drive the vehicle to ensure the condition no longer exists and the vehicle exhibits proper operation

◀ VERIFY REPAIR QUALITY ▶

- Confirm the high voltage bolts are properly torqued to specification.
- Confirm the MGR bolts are torqued to specification and that the rear mount is properly aligned.
- Confirm the cables are properly routed and secured.
- Confirm related DTCs P0AA649 and/or P1C8049 are no longer present.

If you have any questions regarding this update, please contact your regional representative.