



TECHNICAL SERVICE BULLETIN

2019-2021 Transit - Driver Seat Cushion Sagging - Built On Or Before 11-Feb-2021

24-2053

14 March
2024

This bulletin supersedes 23-2235. Reason for update: revised Part List and update Step 2 of the Service Procedure

Model:

Ford 2019-2021 Transit	Built on or before 11-Feb-2021
---------------------------	--------------------------------

Markets: Published by Ford North America

Issue: Some 2019-2021 Transit vehicles built on or before 11-Feb-2021 may experience a front seat cushion sagging. The vehicle may also exhibit an illuminated air bag warning indicator with DTCs B1408, B1405, B1407, B0001, B0010 and/or B1404 stored in the RCM. To correct this condition, follow the Service Procedure to replace the suspension mat assembly and install additional webbing strap assemblies to the seat frame.

Action: Follow the Service Procedure to correct the condition on vehicles that meet all of the following criteria:

- 2019-2021 Transit
- Built on or before 11-Feb-2021
- At least one of the following conditions:
 - Driver seat cushion sagging
 - Illuminated air bag warning indicator with DTCs B1408, B1405, B1407, B0001, B0010 and/or B1404

Parts

Service Part Number	Claim Quantity	Package Order Quantity	Number in Package	Description
LK4Z-61632A22-C	1	1	1	Front Seat Cushion Repair Kit
LK4Z-6162948-A	2	2	1	Front Seat Cushion Strap
CK4Z-9961711-H	1	1	1	Seat Track Assembly
CK4Z-14611D10-A	1	1	1	Side Airbag - Vehicles Equipped With Standard Seat
LK4Z-14611D10-A	1	1	1	Side Airbag - Vehicles Equipped With Swivel Seat

Claim Quantity refers to the total number of individual pieces required to repair the vehicle.

Package Order Quantity refers to the amount of the service part number package(s) required to repair the vehicle.

Number In Package refers to the number of individual pieces included in a service part number package.

Labor Times

Description	Operation No.	Time
2019-2021 Transit: Retrieve DTCs, Install The Seat Cushion Service Kit In The Right Front Seat Includes Time To Remove And Install Seat (Can Be Claimed With Operation D And F) (Do Not Use With Any Labor Operations Outside Of This Article)	242053A	1.0 Hrs.
2019-2021 Transit: Retrieve DTCs, Install The Seat Cushion Service Kit In The Left Front Seat Includes Time To Remove And Install Seat (Can Be Claimed With Operation D Or E And F Or G) (Do Not Use With Any Labor Operations Outside Of This Article)	242053B	1.0 Hrs.

2019-2021 Transit: Retrieve DTCs, Install The Seat Cushion Service Kit In Both Right And Left Front Seats Includes Time To Remove And Install Seats (Can Be Claimed With Operation D Or E And F Or G) (Do Not Use With Any Labor Operations Outside Of This Article)	242053C	1.7 Hrs.
2019-2021 Transit: Additional Time To Be Used When Seat Track Assembly Is Replaced One (1) Front Seat (Can Be Claimed With Operation A-C) (Do Not Use With Any Labor Operations Outside Of This Article)	242053D	0.4 Hrs.
2019-2021 Transit: Additional Time To Be Used When Seat Track Assembly Is Replaced Both (2) Front Seats (Can Be Claimed With Operation C) (Do Not Use With Any Labor Operations Outside Of This Article)	242053E	0.7 Hrs.
2019-2021 Transit: Additional Time To Be Used When Side Airbag Is Replaced One (1) Front Seat (Can Be Claimed With Operation A-C) (Do Not Use With Any Labor Operations Outside Of This Article)	242053F	0.5 Hrs.
2019-2021 Transit: Additional Time To Be Used When Side Airbag Is Replaced Both (2) Front Seats (Can Be Claimed With Operation C) (Do Not Use With Any Labor Operations Outside Of This Article)	242053G	1.0 Hrs.

Repair/Claim Coding

Causal Part:	9961711
Condition Code:	01

Service Procedure

1. Remove the affected driver seat track. Refer to WSM, Section 501-10A, starting with Step 2.
2. Inspect the seat airbag deployment circuit for damage as shown in Figure 1. If damage is present, replace the side airbag. Refer to WSM, Section 501-20B.

Figure 1

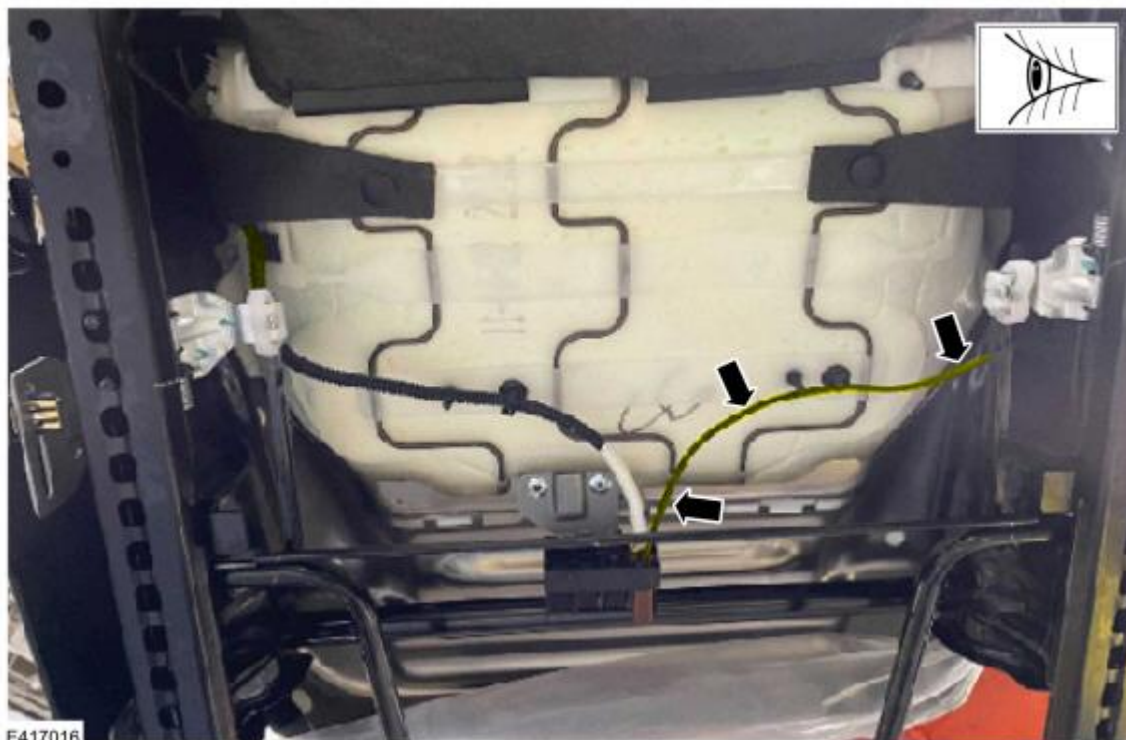

3. Inspect the driver seat track assembly for damage. Is the driver seat track assembly damaged?

NOTE: Small cracks around the bolt are considered normal. (Figure 2)

Figure 2



E390181

(1). Yes - replace the seat track assembly. Refer to WSM, Section 501-10A Front Seats > Removal and Installation > Front Seat Track. Proceed to Step 5.

(2). No - proceed to Step 4.

4. Remove the damaged suspension mat assembly.

(1). Remove all wire harness attachments (fir trees) from the suspension mat assembly.

(2). Disengage the 3 suspension mat assembly forward attachments from the cushion pan. (Figure 3)

Figure 3

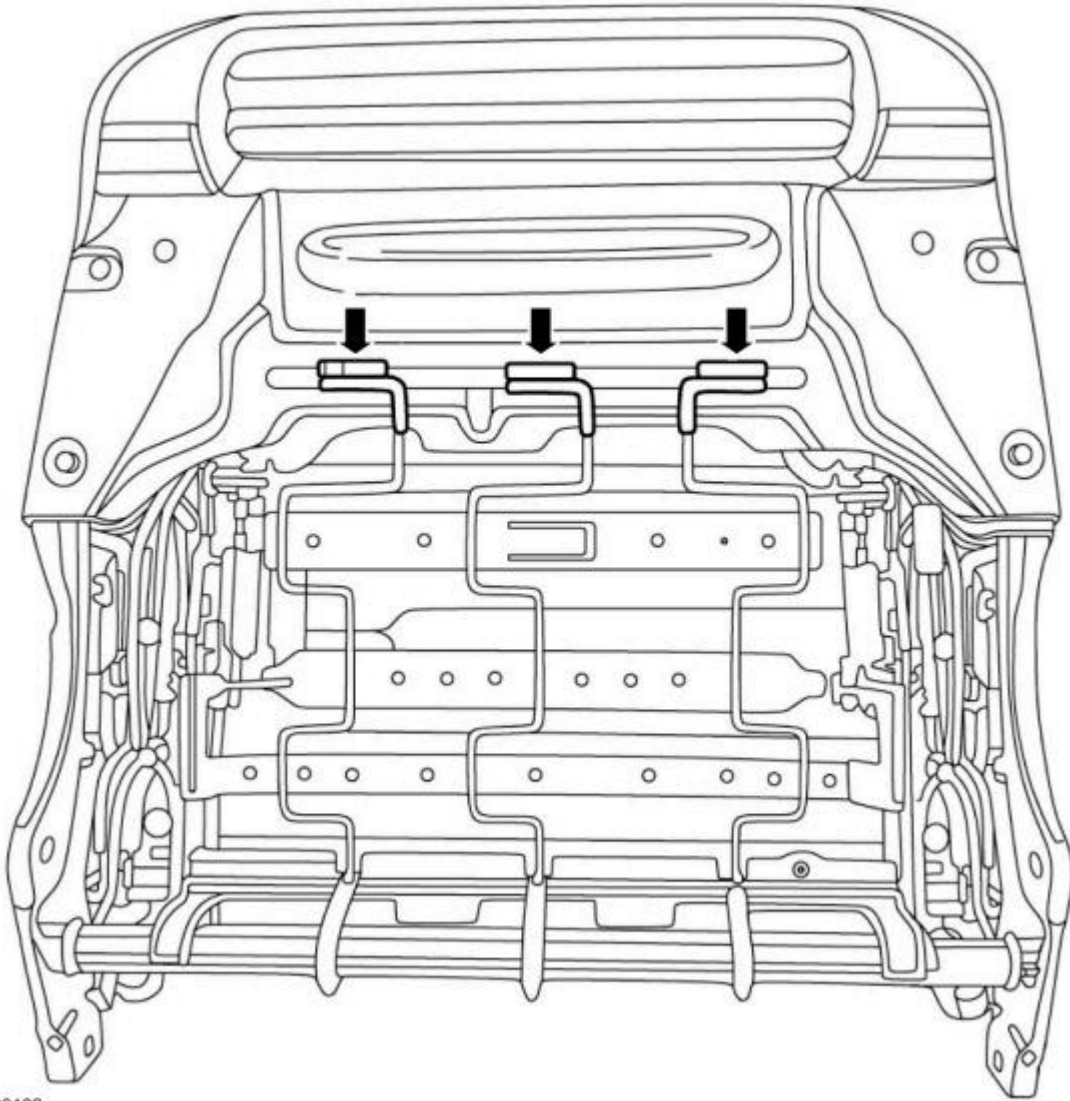

E390182

(3). Remove the suspension mat assembly 3 rearward attachments. The suspension mat assembly has a snap fit on the rear tube. (Figure 3)

5. Install 2 webbing straps assemblies. Installation shown from the under-side of cushion assembly.

(1). With the red thread visible, route the end of the 1st webbing strap assembly without the metal ring between the cushion pan and the front cross-car tube. (Figure 4)

Figure 4

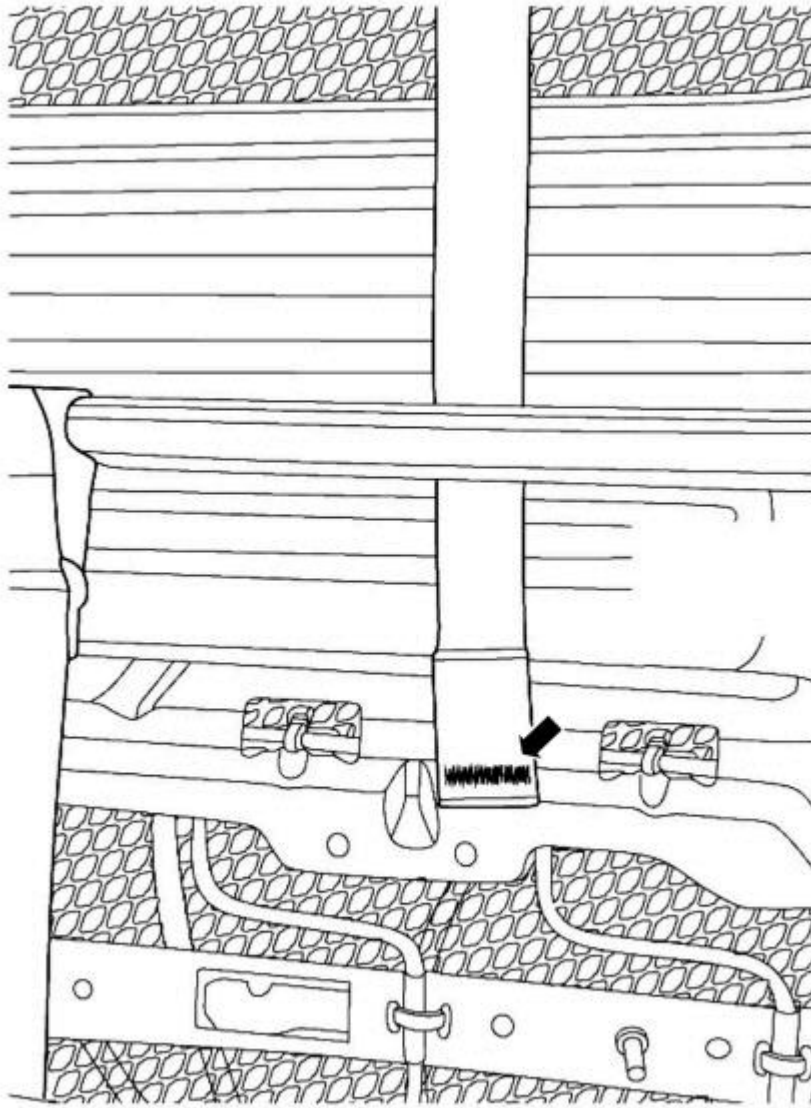

E390183

(2). Continue rearward and route the webbing strap assembly between the suspension mat assembly and the rear tube. (Figure 5)

Figure 5

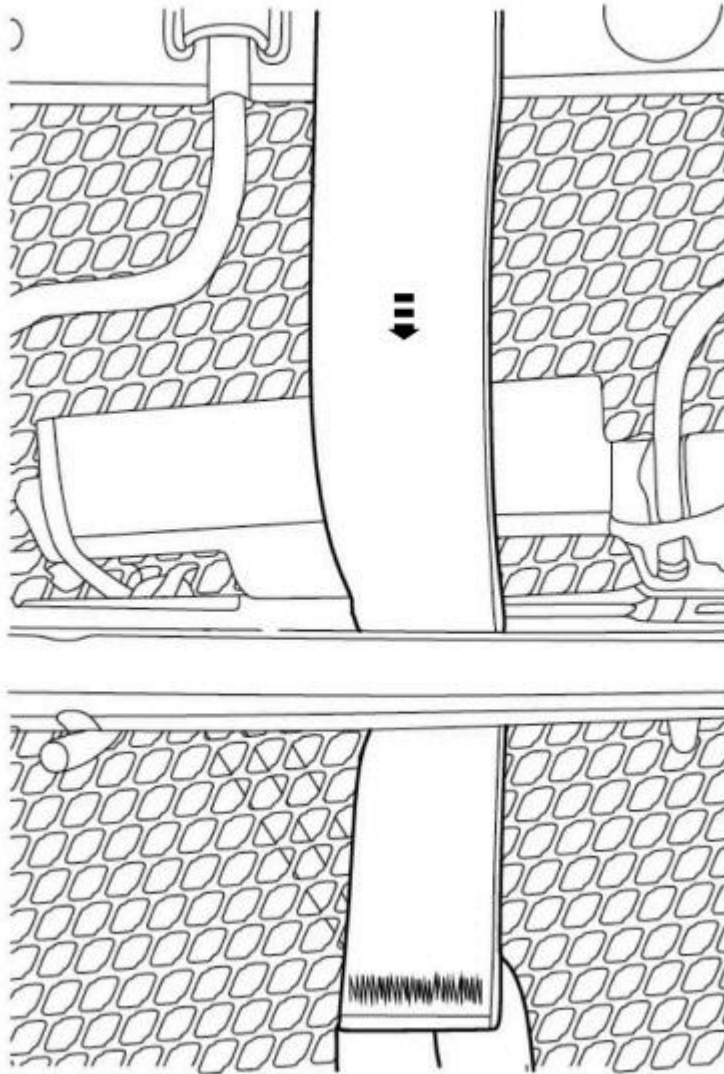

E390184

(3). Make sure all electrical harnesses are below the webbing. The final assembly will have the suspension mat on top (closest to the seat cushion), then the webbing straps, and then the wire harnesses on the bottom. (Figure 6)

Figure 6

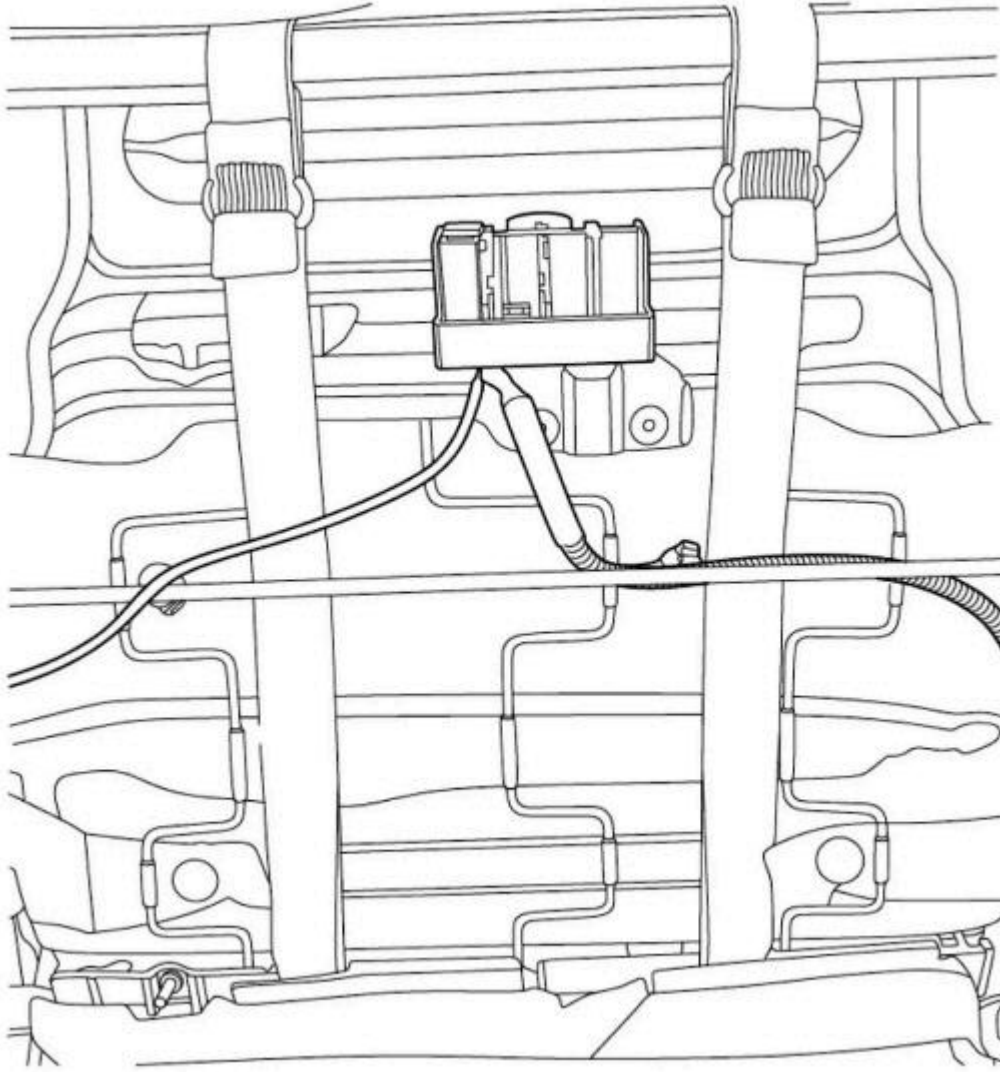

E390185

(4). Bring the webbing strap assembly to the metal ring and insert it. After the fold is all the way through the ring, pull the retention fold back and into position. (Figure 7)

Figure 7

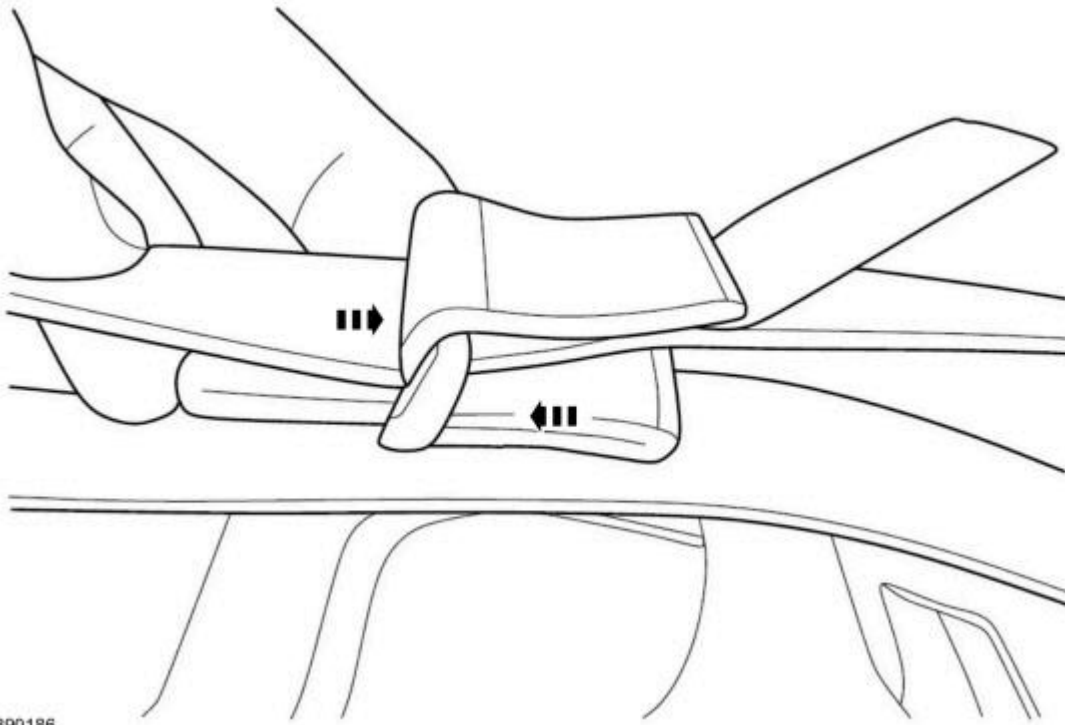

E390186

(5). Repeat the process to install the second webbing strap assembly.

(6). The metal ring should be positioned forward in vehicle. (Figure 8)

Figure 8

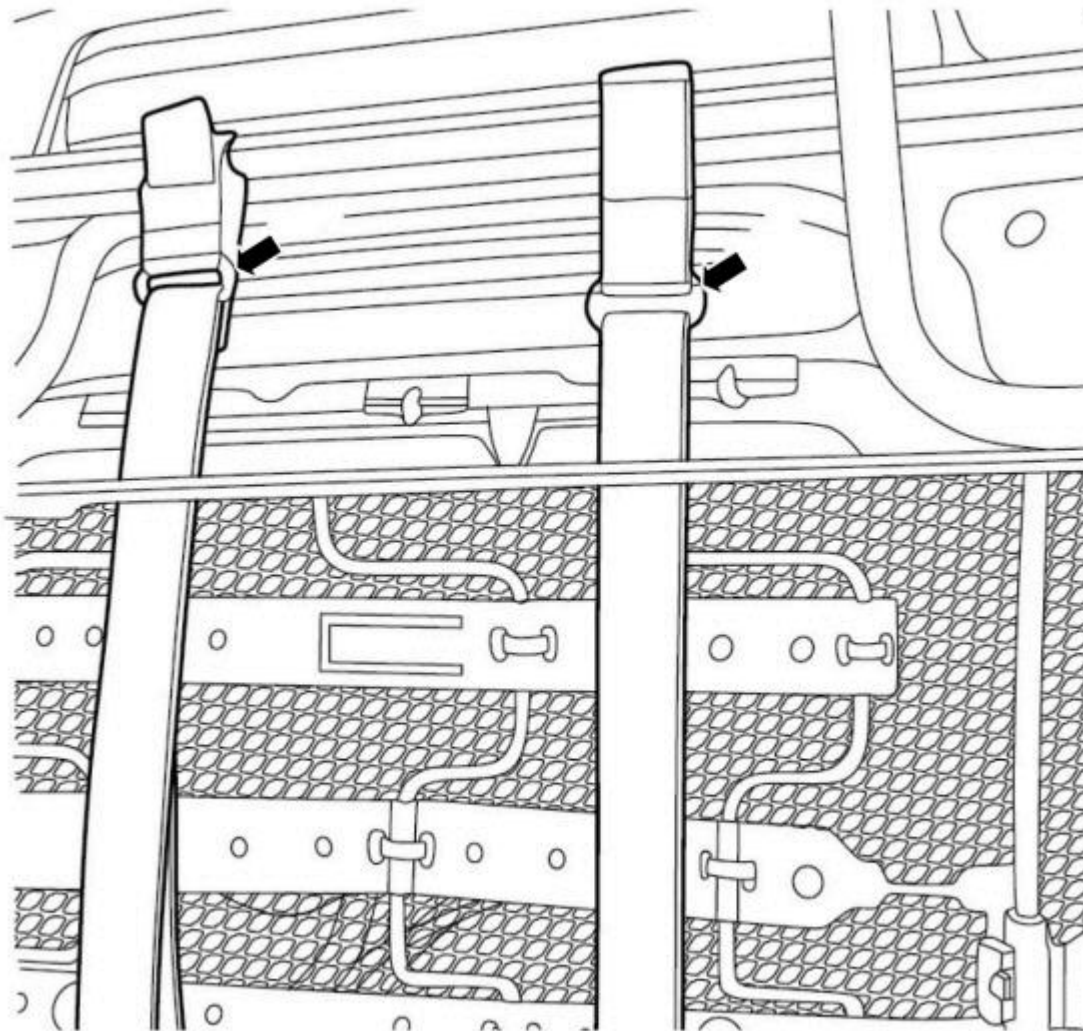

E390187

6. Install the new suspension mat assembly from the service kit.

(1). Locate the suspension mat to the cushion and webbing assembly.

(2). At the rear tube verify one webbing is located between the left and center suspension attachment and the other is between the center and right suspension attachment. (Figure 9)

Figure 9

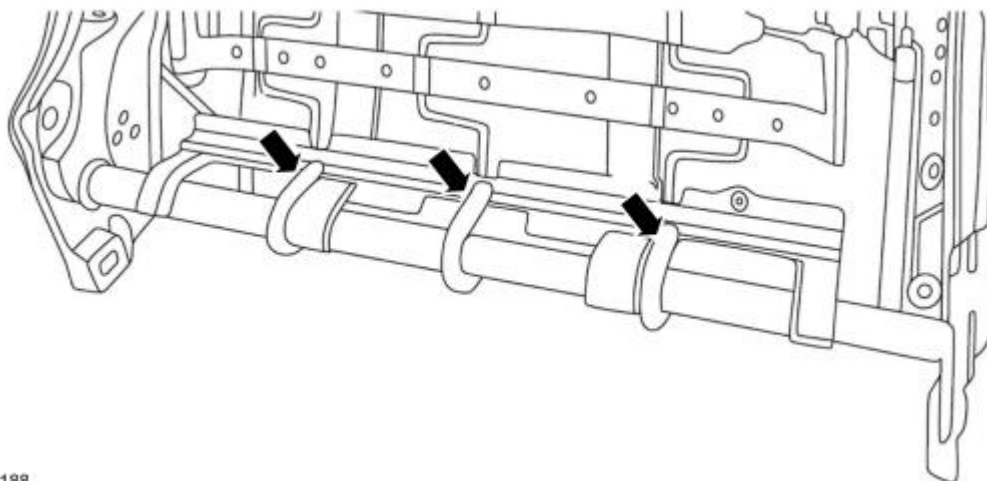

E390188

(3). Apply force to secure the rear attachment features, attachment feature is a snap-on.

(4). Secure the front of the suspension mat to the retaining tabs on the cushion pan (no tools required). (Figure 10)

Figure 10

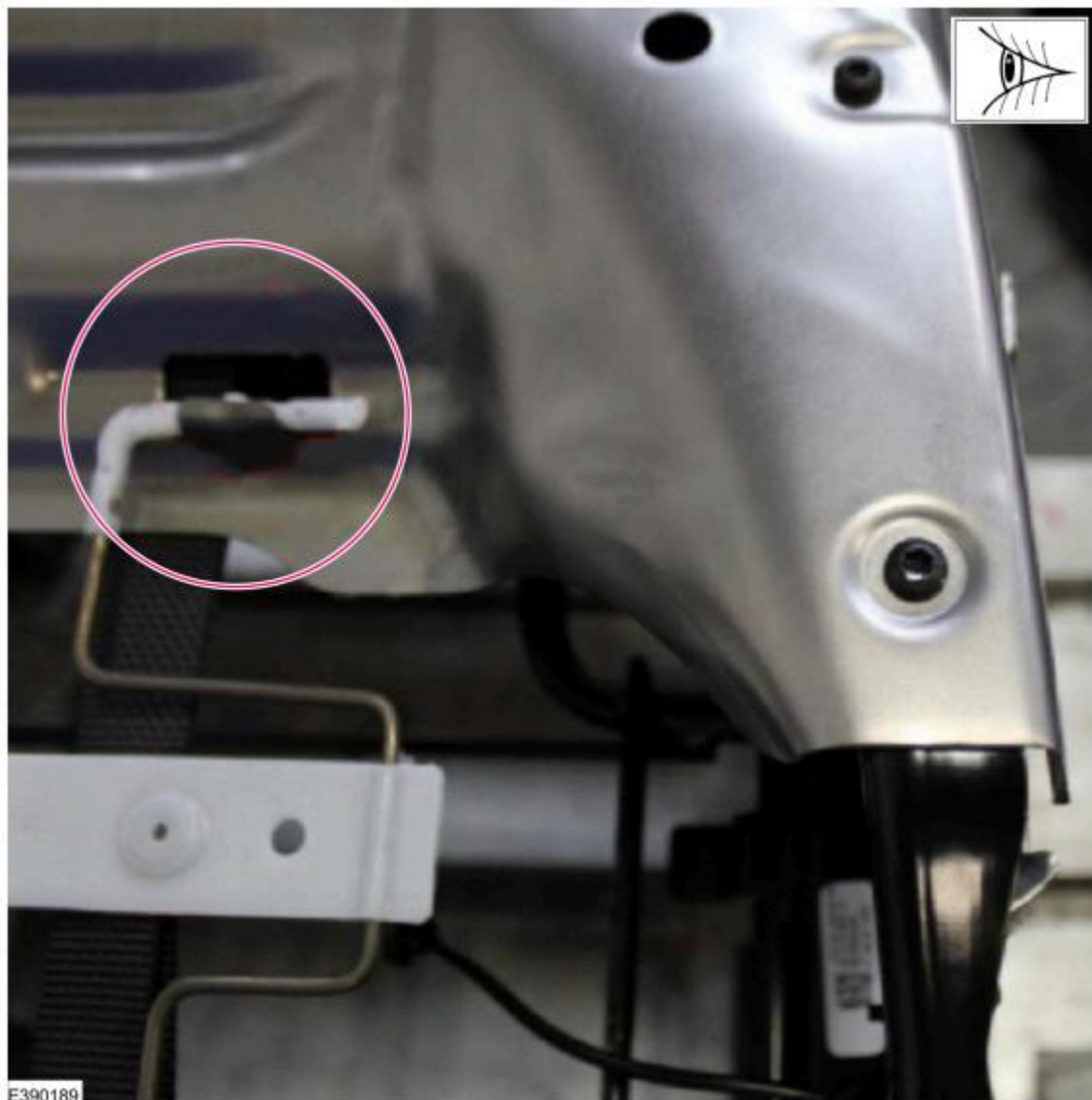

(5). Verify the cross-car position of the webbings. The position should be aligned with the stud on the suspension mat. (Figure 11)

Figure 11

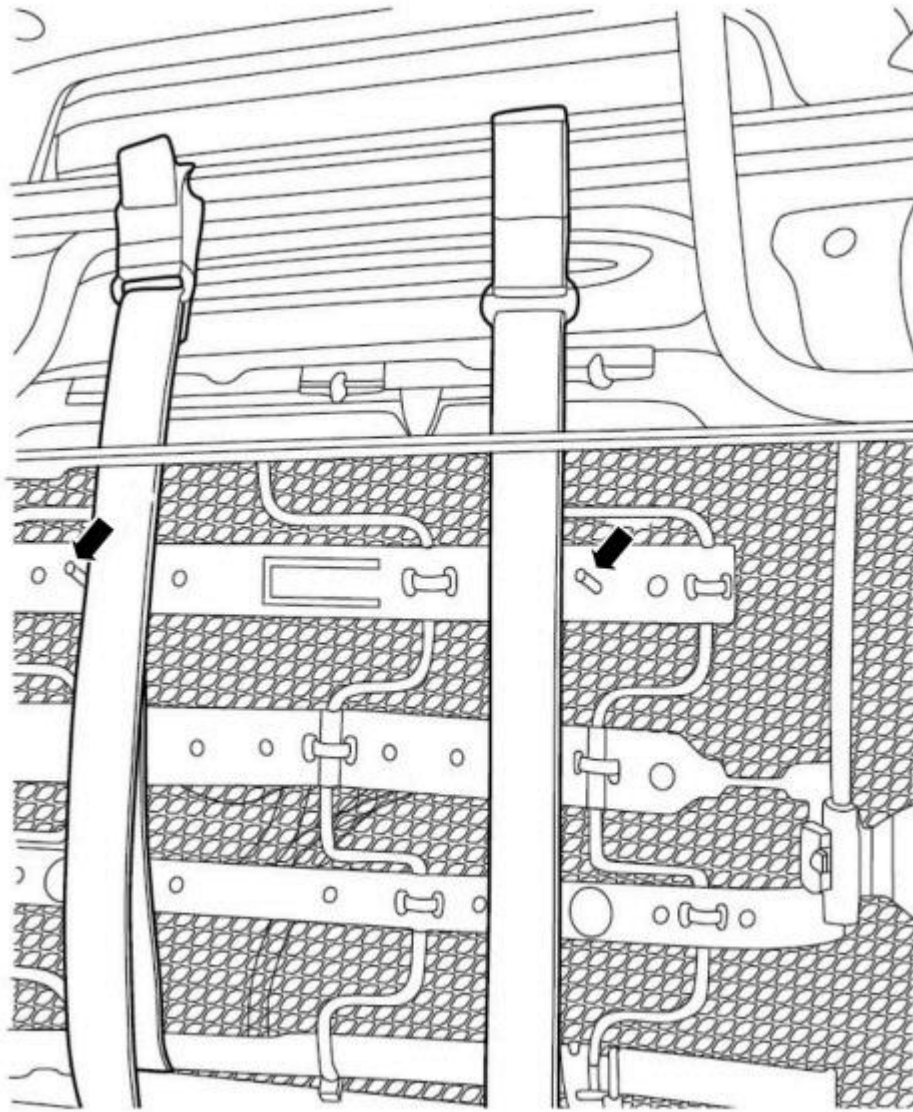

E390190

(6). Secure the wire harness(es) to the suspension mat. (Figure 12)

Figure 12

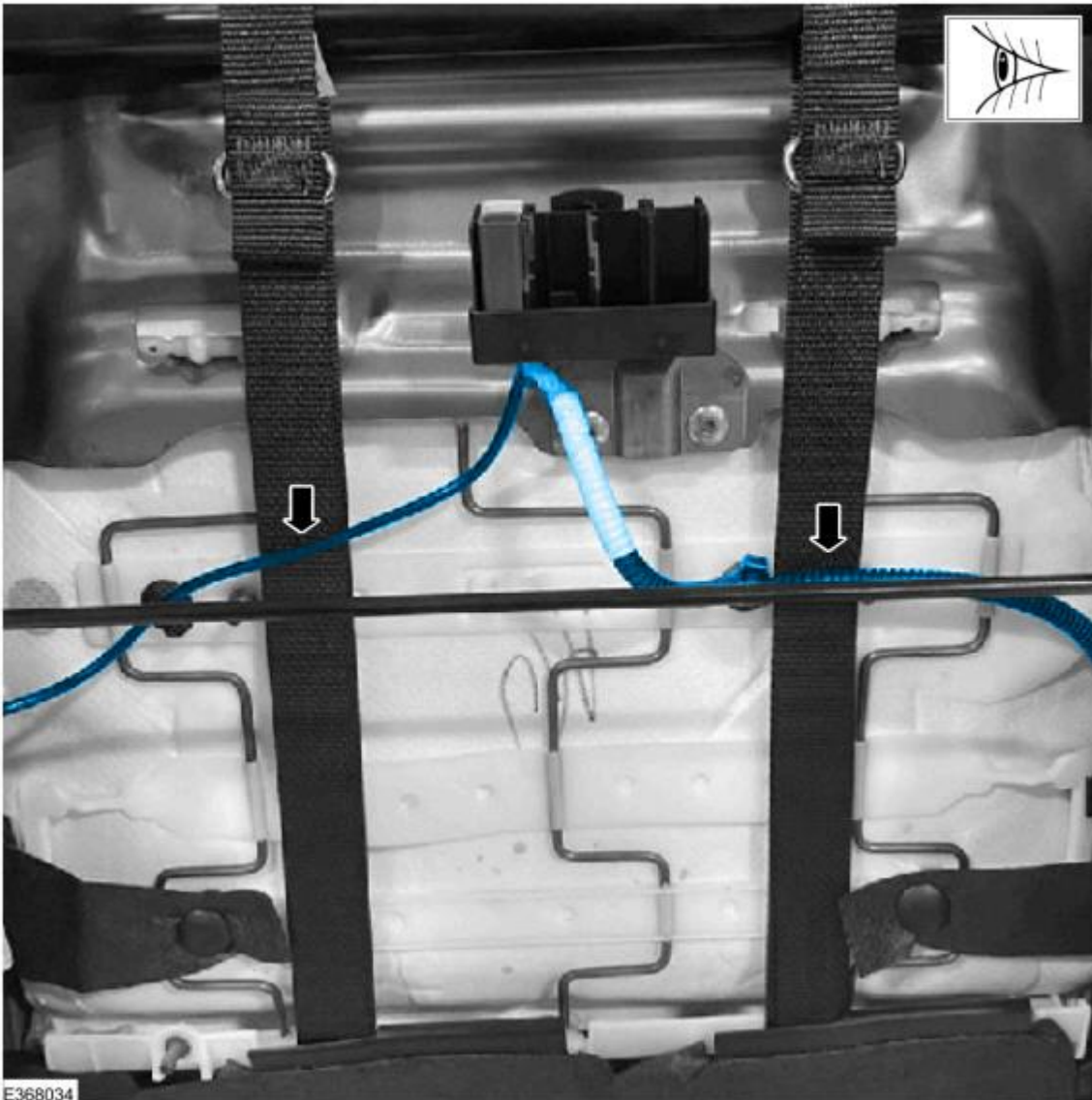

NOTE: Make sure all electrical harnesses hang below the webbing and not between the webbing and suspension mat. When the final assembly is installed in the vehicle, it will have the suspension mat on top (closest to the cushion), then the webbing straps, and then the wire harnesses on the bottom. (Figure 6)

7. Notch the cushion trim rear j-retainers for clearance to the webbings.

(1). Measure 1 3/4 in. (45 mm) and cut with a knife along the dotted line. (Figure 13)

Figure 13

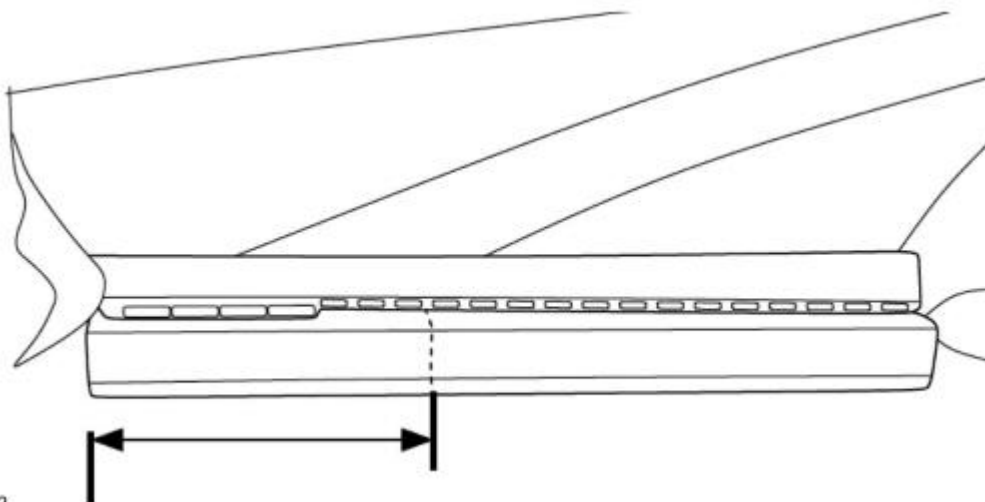

(2). Cut along the dotted line (Figures 14-15), perpendicular to the previous cut, so that the portion of the J retainer in Figures 16 and 17 can be removed.

Figure 14

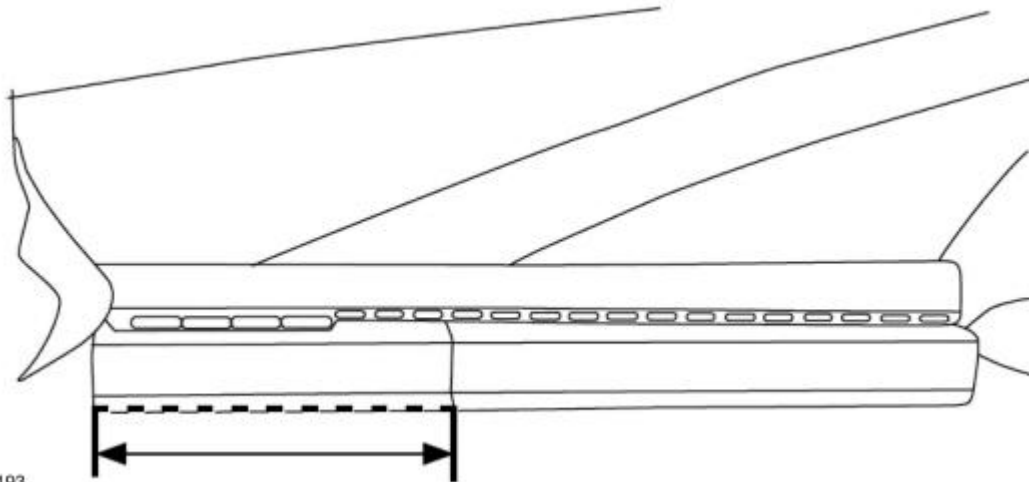

Figure 15



Figure 16

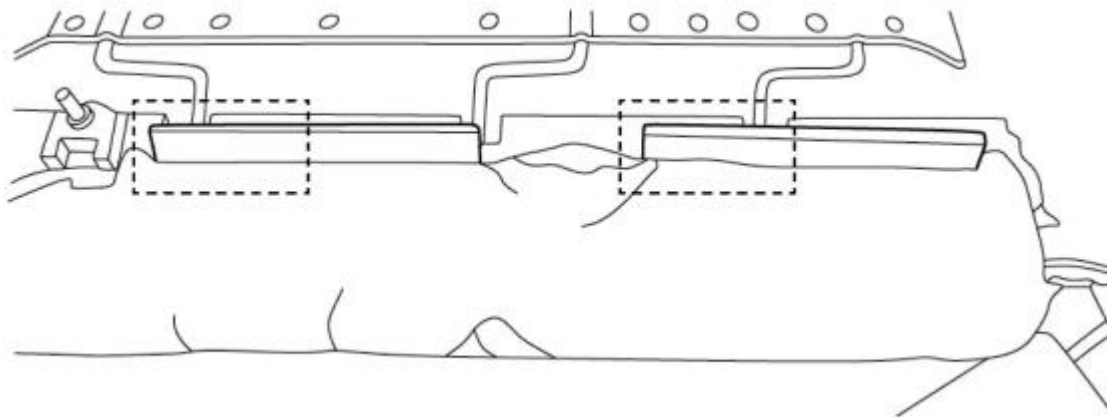

Figure 17



E390195

8. Reinstall the affected driver seat track. Refer to WSM, Section 501-10A.

© 2024 Ford Motor Company

All rights reserved.

NOTE: The information in Technical Service Bulletins is intended for use by trained, professional technicians with the knowledge, tools, and equipment to do the job properly and safely. It informs these technicians of conditions that may occur on some vehicles, or provides information that could assist in proper vehicle service. The procedures should not be performed by "do-it-yourselfers". Do not assume that a condition described affects your car or truck. Contact a Ford or Lincoln dealership to determine whether the Bulletin applies to your vehicle. Warranty Policy and Extended Service Plan documentation determine Warranty and/or Extended Service Plan coverage unless stated otherwise in the TSB article. The information in this Technical Service Bulletin (TSB) was current at the time of printing. Ford Motor Company reserves the right to supersede this information with updates. The most recent information is available through Ford Motor Company's on-line technical resources.