

April 2024
SF682AB

Subject: AB12 and Crash Sensors

Models Affected: Specific model years 2023-2024 Freightliner eCascadia vehicles manufactured January 19, 2022, through May 30, 2023.

General Information

Daimler Truck North America LLC (DTNA), on behalf of its Freightliner Trucks Division, is initiating Field Service Campaign SF682AB to modify the vehicles mentioned above.

Vehicles were built with numerous protections against crash-related damages or high voltage hazards. Early production units were installed with a prior version of AB12 modules and with forward crash sensors not engaged. These will be replaced by upgraded modules with crash sensors engaged. Additionally, optional passenger protection airbag functionality will be enabled on certain vehicles.

There are approximately 366 vehicles involved in this campaign.

Additional Repairs

Dealers must complete all outstanding recall and field service campaigns prior to the sale or delivery of a vehicle. A dealer will be liable for any progressive damage that results from its failure to complete campaigns before sale or delivery of a vehicle.

Owners may be liable for any progressive damage that results from failure to complete campaigns within a reasonable time after receiving notification.

Please contact Warranty Campaigns for consideration of additional charges prior to performing the repair.

Work Instructions

Please refer to the attached work instructions. Prior to performing the campaign, check the vehicle for a completion sticker (Form WAR261).

Replacement Parts

Replacement parts are now available and can be obtained by ordering the kit and/or part number(s) listed below from your facing Parts Distribution Center (PDC).

If our records show your dealership has ordered any vehicle(s) involved in campaign number SF682, a list of the customers and vehicle identification numbers will be available on the DTNA Portal via OWL. Please refer to this list when ordering parts for this campaign.

Table 1 - Replacement Parts for SF682AB

Campaign Number	Part Description	Part Number	Qty. per Kit
SF682A	SENSOR - CRASH	A18-74629-000	1 ea
SF682B	SENSOR - CRASH	A18-74629-001	1 ea
SF682AB	BLANK COMPLETION STICKER	WAR260	1 ea

Table 1

Removed Parts

U.S. and Canadian Dealers, please follow Warranty Failed Parts Tracking shipping instructions for the disposition of all removed parts. Export distributors, please destroy removed parts unless otherwise advised.

April 2024
SF682AB

Labor Allowance

Table 2 - Labor Allowance

Campaign Number	Procedure	Time Allowed (hours)	SRT Code	Corrective Action
SF682AB	Replace AB12 sensor and connect crash sensors	1.2	996-F210A	12-Repair Recall/Campaign

Table 2

IMPORTANT: When the campaign has been completed, locate the base completion label in the appropriate location on the vehicle, and attach the gray completion sticker provided in the field service kit (Form WAR261). If the vehicle does not have a base completion label, clean a spot on the appropriate location of the vehicle and first attach the base completion label (Form WAR259). If a field service kit is not required or there is no completion sticker in the kit, write the campaign number on a blank sticker and attach it to the base completion label.

Claims for Credit

You will be reimbursed for your parts, labor, and handling (landed cost for Export Distributors) by submitting your claim through the warranty system within 30 days of completing this campaign. Please reference the following information in OWL:

- Claim type is **Field Service Campaign**.
- In the Campaign field, enter the campaign number and appropriate condition code (**SF682-A** or **SF682-B**).
- In the Primary Failed Part field, enter **25-SF682-000**.
- In the Parts section, enter the appropriate kit or part number(s) as shown in the Replacement Parts Table.
- In the Labor section, enter the appropriate SRT from the Labor Allowance Table. Administrative time will be included automatically as SRT 939-6010A for 0.3 hours.
- The VMRS Component Code is **F99-999-005** and the Cause Code is **A1 - Campaign**.
- This Field Service Campaign will **terminate on April 30, 2025**. Dealers will be notified of any changes to the termination date via an Important Campaign Information Letter (ICI) posted on the DTNA Portal.

IMPORTANT: OWL must be viewed prior to beginning work to ensure the vehicle is involved and the campaign has not previously been completed. Also, check for a completion sticker before beginning work.

All claims must be submitted within 30 days of the repair and within 30 days of the termination date of the campaign. U.S. and Canadian Dealers: All excess inventory to be returned to the PDC following the conclusion of the campaign must be returned in resaleable condition to the Memphis PDC within 90 days from the termination date. Please submit a PAR to request return to the Memphis PDC. (Canadian dealers should return the kits to their facing PDC.)

For questions, U.S. and Canadian dealers, contact the Warranty Campaigns Department using the Warranty Support Center (WSC) app located on the DTNA Portal. Export distributors submit a WSC inquiry or contact your International Service Manager.

April 2024
SF682AB

Copy of Notice to Owners

Subject: AB12 and Crash Sensors

Daimler Truck North America LLC (DTNA), on behalf of its Freightliner Trucks Division, is initiating Field Service Campaign SF682 to modify specific model years 2023-2024 eCasadia vehicles, manufactured January 19, 2022, through May 30, 2023.

Vehicles were built with numerous protections against crash-related damages or high voltage hazards. Early production units were installed with a prior version of AB12 modules and with forward crash sensors not engaged. These will be replaced by upgraded modules with crash sensors engaged. Additionally, optional passenger protection airbag functionality will be enabled on certain vehicles.

Please contact an authorized DTNA dealer to arrange to have the campaign performed and to ensure that parts are available at the dealership. The campaign will take approximately one hour and will be performed **free of charge**. To locate an authorized dealer, search online at northamerica.daimlertruck.com/contact-us. Scroll down to "Locate a Dealer," and select the appropriate brand.

This Field Service Campaign will **terminate on April 30, 2025**. Please make sure the campaign is completed prior to this date. Work completed after this date will be done at the customer's expense.

As stated in the terms of your express limited warranty, DTNA will not pay for any damage caused by failure to properly maintain your vehicle. DTNA considers the work necessary under this campaign to be proper maintenance and will, therefore, not pay for any damage to your vehicle caused by your failure to have the repairs that are the subject of this campaign performed in a reasonable time.

Contact the Warranty Campaigns Department at (800) 547-0712, from 7 a.m. to 4 p.m. Pacific Time, Monday through Friday, e-mail address DTNA.Warranty.Campaigns@DaimlerTruck.com, or the Customer Assistance Center at (800) 385-4357, if you have any questions or need additional information.

WARRANTY CAMPAIGNS DEPARTMENT

Enclosure

April 2024
SF682AB

Work Instructions

Subject: AB12 and Crash Sensors

Models Affected: Specific model years 2023-2024 Freightliner eCascadia vehicles manufactured January 19, 2022, through May 30, 2023.

Replacement of the Air Bag Sensor (AB12)

1. Check the base label (Form WAR259) for a completion sticker for SF682 (Form WAR261), indicating this work has been done. The base label is usually located on the passenger-side door, about 12 inches (30 cm) below the door latch. If a completion sticker is present, no work is needed. If a completion sticker is not present, proceed to the next step.
2. Park the vehicle on a level surface, place the vehicle in neutral, shut down the vehicle, and set the park brake. Chock the tires.
3. Disconnect the low-voltage batteries. For instructions, see **Section 54.08** of the *eCascadia Workshop Manual*.
4. Open the driver-side door.

 **CAUTION**

Do not remove the seat air spring without first using an appropriate method to secure the seat suspension in the extended position. If the seat suspension is not properly secured, the seat could lower unexpectedly, pinching a hand or finger between the suspension parts, resulting in personal injury.

5. Drain all the air from the air tanks.

 **WARNING**

Air lines under pressure can whip dangerously if disconnected. Drain all air from the air tanks before disconnecting air lines. Disconnecting pressurized air lines can cause personal injury and/or property damage.

April 2024
SF682AB

6. Disconnect the power supply from the seat, if applicable. See **Fig. 1**.

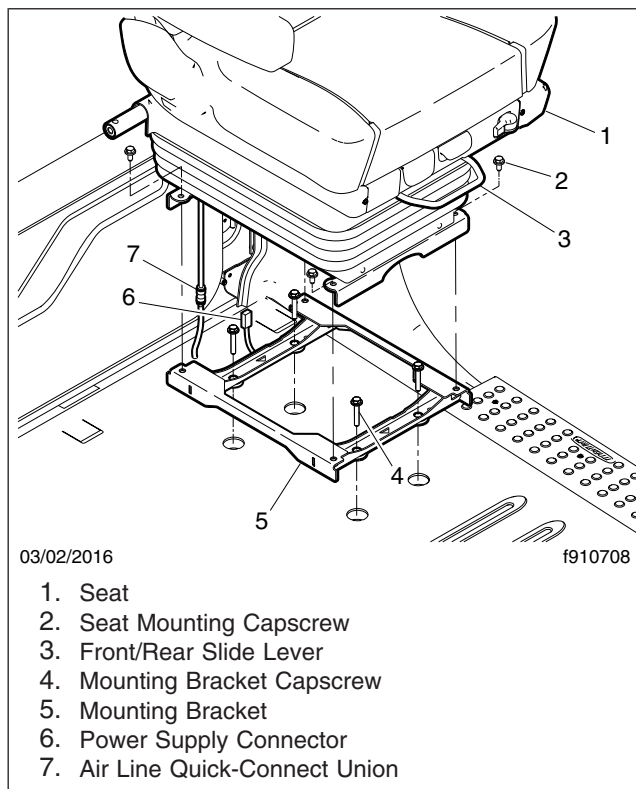

Fig. 1, Seat Installation

7. Disconnect the air supply tubing from the quick-connect union behind the seat.

April 2024
SF682AB

- Remove the Torx® screws that attach the seat belt and tether belts to the intermediate-connection-point (ICP) bar. See [Fig. 2](#).

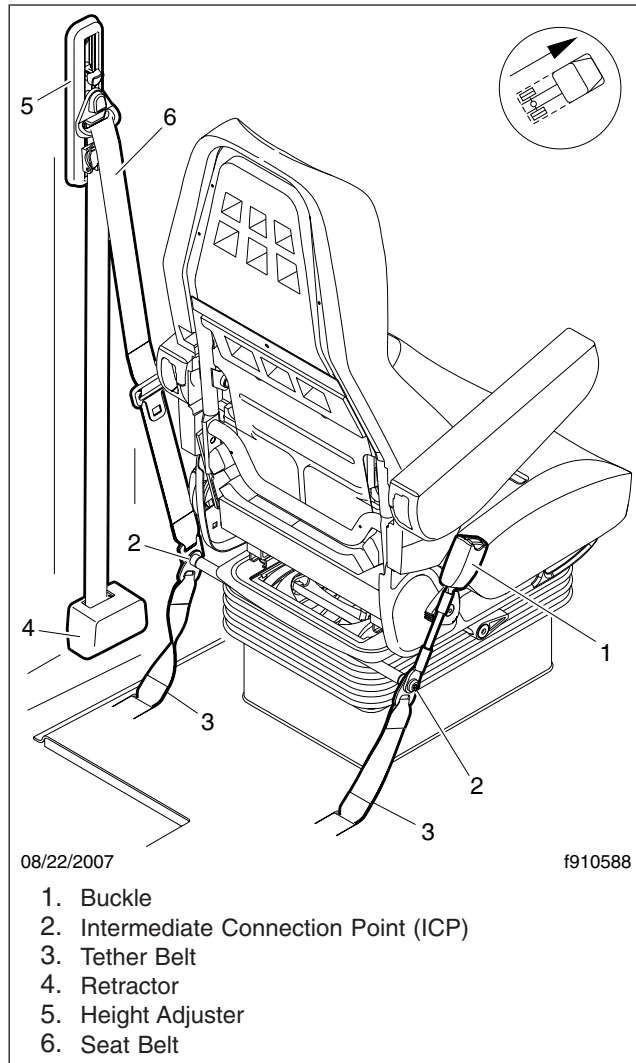

Fig. 2, Seat Belt Installation, Air Suspension Seats

NOTICE

Do not use the front/rear slide lever, shown as item 3 in [Fig. 1](#), as a lift handle when removing or installing the seat. Doing so will damage the lever and prevent operation of the front/rear slide.

- Remove the four capscrews that attach the seat to the mounting bracket.
- To get access to the air bag sensor mounting fasteners, tilt the seat over.
- To get access to the air bag sensor plug, remove the sill cover and pull back the weather stripping.
- Disconnect the electrical connector from the air bag sensor.
- Pull the wiring from under the floor mat.

April 2024
SF682AB

14. Remove the capscrews from the air bag sensor, and remove the seat bracket. See [Fig. 3](#).
15. Remove the air bag sensor.

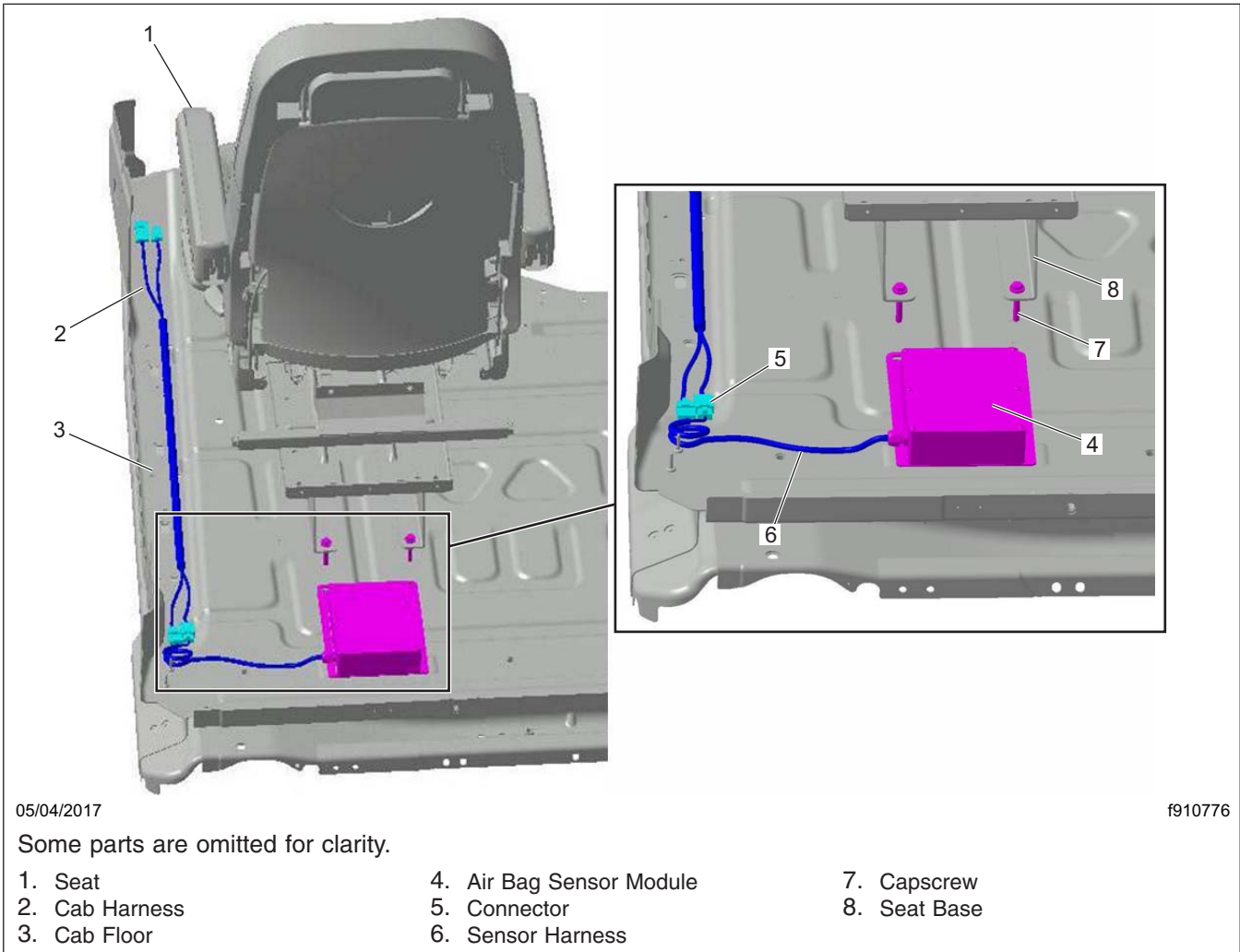

Fig. 3, Air Bag Sensor Removal

NOTE: Do not connect the low-voltage harness to the air bag sensor yet.

16. Install the new air bag sensor, and route the low-voltage cable.
17. Install the seat bracket and the air bag sensor mounting fasteners. Tighten the fasteners 12 lbf-ft (16 N·m).
18. Connect the low-voltage harness to the air bag sensor.
19. Install the sill cover, and put the weather stripping back in place.
20. Position the seat in place, and install the seat mounting fasteners. Tighten the fasteners 12 lbf-ft (16 N·m).
21. Install the seat belt mounting fasteners, and tighten 41 lbf-ft (56 N·m).

April 2024
SF682AB

22. Connect the air supply by pressing the tubing to the quick-connect union behind the seat.

IMPORTANT: Check the radiator-mounted crash sensor connectors for any sign of dirt/corrosion. Clean or repair, as required. If the front crash sensors are damaged or corroded, replace with:

- A66-30389-000 – Left-hand front sensor assembly
- A66-30389-001 – Right-hand front sensor assembly

23. Connect the power supply to the seat, if applicable.

IMPORTANT: Check the radiator-mounted crash sensor connectors for any signs of dirt/corrosion. Clean or repair, as required.

24. Connect the electrical connectors to the radiator-mounted crash sensors. See **Fig. 4**.



Fig. 4, Radiator-Mounted Crash Sensor

25. Connect the low-voltage batteries. For instructions, see **Section 54.08** of the *eCascadia Workshop Manual*.

26. Turn the ignition key to the ON position, and check for active fault codes in DiagnosticLink®.

27. Clean a spot on the base label (Form WAR259), and attach a campaign completion sticker for SF682 (Form WAR261), indicating this work has been completed.