

**TITLE: 2024 Z e-1 ABS & NINJA® e-1 ABS Battery Lead Wire Replacement****FACTORY DIRECTED MODIFICATION****IMMEDIATE REPAIR REQUIRED****Eligibility****Eligible Units**

Year	Model Name	Model Code
2024	Z e-1 ABS NINJA e-1 ABS	NR011ARFNN NX011ARFNN

**Verify individual vehicle eligibility using VIP in K-Dealer before starting the repair.**

Please check VIP (Vehicle Information Portal) in K-Dealer for other possible repair campaigns for eligible units.

**Subject**

On certain eligible units, the 12V battery lead wire terminals may break off due to a faulty manufacturing process.

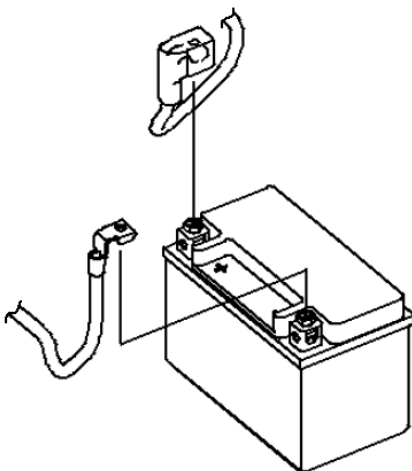
**Kawasaki Action****Initiate Campaign:**

Kawasaki has initiated an FDM campaign to replace the positive and negative battery lead wires.

**Notify Registered Owners:**

Kawasaki is sending an FDM letter to all registered owners of eligible units. A copy of the letter is printed on page 17 of this bulletin.

**Dealer Action****Repair Eligible Units:**

Repair all eligible units including sold units in the field and unsold units in your dealership inventory prior to delivery to the retail purchaser. It is the obligation of authorized Kawasaki retail Dealers to repair eligible units in Dealer's possession prior to retail sale. Failure to comply with this obligation to repair all units eligible for Recall or FDM campaigns by the Dealer constitutes a breach of the Dealer Sales and Service Agreement. Refer to Service Policies bulletin SP 08-01. Refer to the Repair Procedure section of this bulletin for details.

**NOTE:**

- o If you fail to submit a Warranty Claim for a new unit that is subsequently sold and registered, the new owner will receive the FDM letter requesting the return of the vehicle to you for repair.

**Submit Product Registration:**

Submit the product registration to Kawasaki via K-Dealer immediately after retail sale of any eligible unit. Be sure to supply the correct customer name and mailing address. Kawasaki uses the product registration information for customer notification. Also, if you know that the customer has moved, please submit a Customer Update via K-Dealer.

## Parts Information

### Repair Kit Part Number:

### INSTALL REPAIR KIT 99999-0933 ON ALL ELIGIBLE UNITS.

Order parts to complete the FDM through K-Dealer as outlined in Service Bulletin SP15-03.

### Parts Availability:

To ensure parts availability across the dealer network, Kawasaki initially requests that parts are ordered based on immediate demand:

- For retailed units, order parts as customers schedule repairs or for repairs expected to take place within the next two weeks.
- For unsold units, use VIP in K-Dealer to identify the number of affected units in your dealership inventory. Order repair parts only for units that will be repaired for retail sale within the next two weeks.

### NOTE:

- o Use VIP in K-Dealer to identify affected units in your dealership inventory to order repair kits for unsold units.

Kit, Wire Lead, MC24-05, P/N 99999-0933	
Contents	Qty
Wire-Lead, Positive	1
Wire-Lead, Negative	1
Tape	1

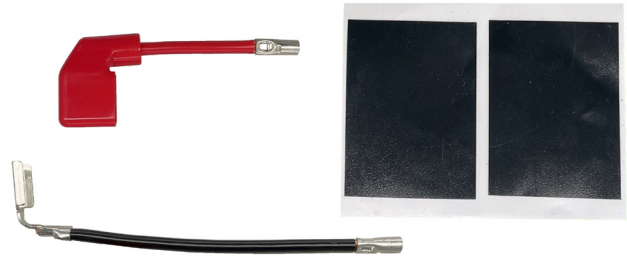

## Recommended Tools & Consumables

- 8mm Socket
- Wire Stripper
- Wire Cutter
- Razor Blade
- Metric Ruler
- Masking Tape
- Vinyl Tape (Black)
- White paint pen
- 5.5mm Non-Insulated Terminal Crimp Tool.



### NOTE:

- o The crimp tool required for this repair is not a common tool. Please purchase the following approved tool. You will be reimbursed for the cost of the tool when you file the claim.

### [CLICK HERE TO ORDER FROM AMAZON](#)

\*Amazon and all related Marks are Trademarks of Amazon.com, Inc. or its affiliates.\*



iCrimp Non-insulated Terminal Crimping Tool for AWG 16 to AWG 10 Non-Insulated Terminals and Butt/Spice/Open/Plug Connectors for Auto Electrical, Marine, Motorcycle Wiring Repairs, Loom Assembly

\$16<sup>99</sup>

prime One-Day  
FREE Returns

Size: IWS-6 AWG16-10

IWS-6 AWG16-10  
\$16.99  
prime

Delivery Pickup

\$16<sup>99</sup>

prime One-Day  
FREE Returns

In Stock

Quantity: 1

Add to Cart

Buy Now

## Repair Procedure

Refer to service manual 99832-0282-02 (Z e-1 ABS) or 99832-0276-02 (NINJA e-1 ABS ) for detailed information related to safety precautions, parts removal and parts installation.

- Remove front and rear seats.
- Remove and retain:
  - o Bolt [A]
  - o Bracket [B]
  - o Battery terminals [C] & [D]
  - o Battery [E]

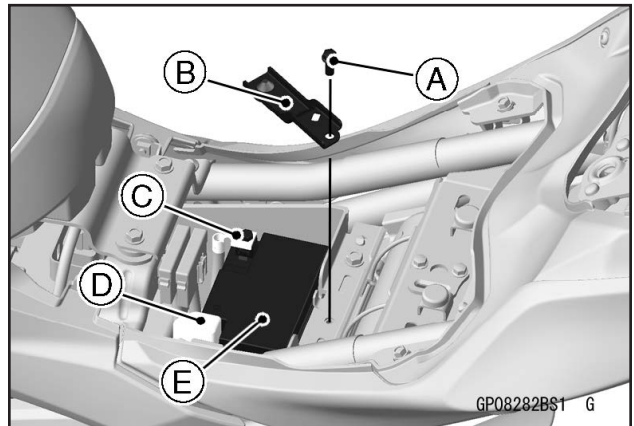

- Unclip fuse boxes [A], [B] & [C] to gain access to the positive and negative battery lead wires.

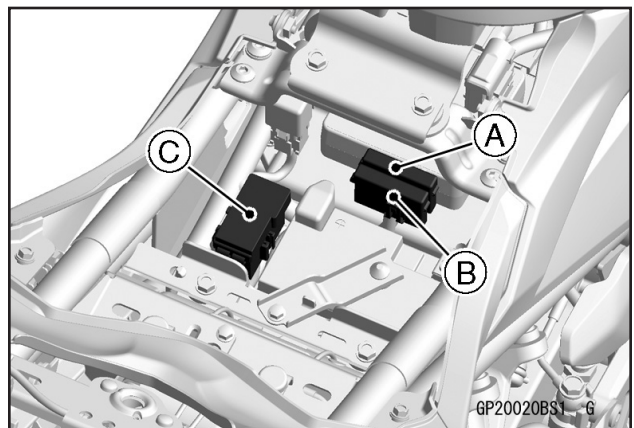

- Cover the left side of the frame and bodywork with masking tape as shown.
- Pull the battery lead wires from the vehicle as shown.

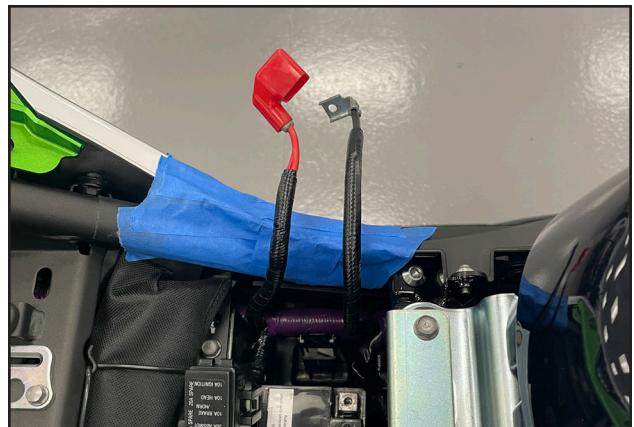

- Tape the positive battery lead [L] to the frame to keep it out of the way temporarily.



## Repair Procedure (continued)

### Replace Negative Lead Wire

- Mark the negative lead wire with a piece of masking tape 160mm from the end of the connector.



- Carefully cut and peel back and remove 160mm of the vinyl tape [T] from negative lead connector wire, making sure to avoid cutting the underlying mesh wire loom [L].

#### NOTE:

- o *Be careful not to cut the mesh wire loom [L] under the vinyl tape.*

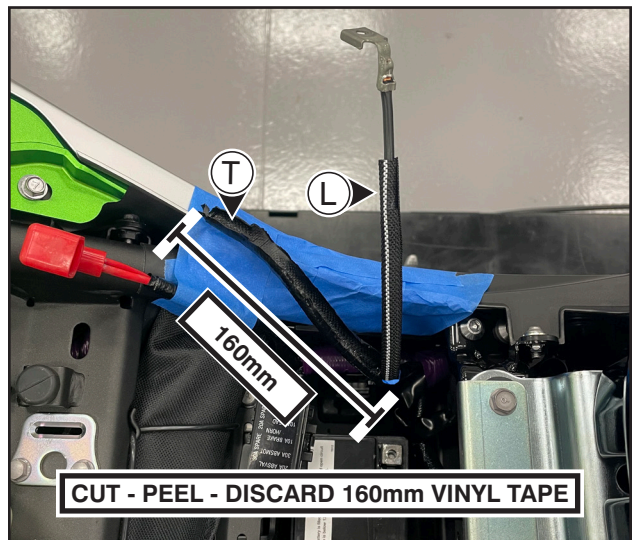

#### NOTE:

- o *Do not cut the mesh wire loom.*
- Remove the negative lead wire [N] from the mesh wire loom [L] taking care not to damage the loom.

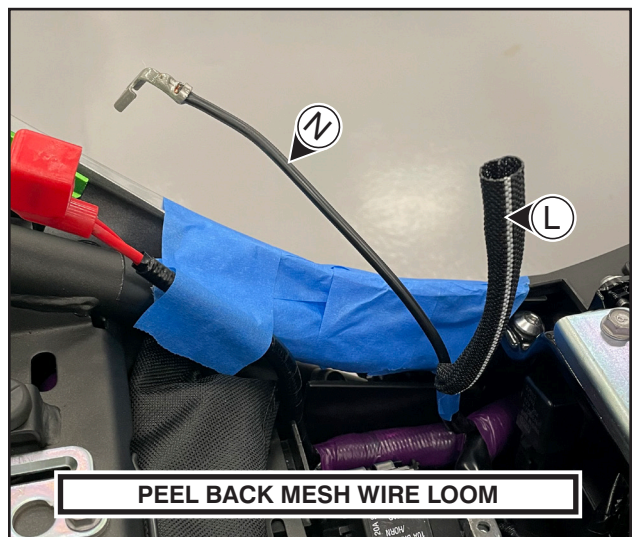

## Repair Procedure (continued)

### Replace Negative Lead Wire (continued)

- Align [A] new lead wire with original.
- Tape the new lead to the original lead.



- Cut the original negative lead wire even with the new connector as shown in the photo to the right.

**NOTE:**

- o *Be careful not to cut the mesh wire loom.*



## Repair Procedure (continued)

### Replace Negative Lead Wire (continued)

- Measure 7mm from the end of the lead wire and mark with a piece of tape.

#### NOTE:

- o *Be careful not to damage the copper wire when stripping the insulation.*

- Strip 7mm insulation from lead wire.

- Insert the exposed wire into the connector of the new lead wire.
- Verify that there is a 1mm gap [G] between the insulation and the connector.

- Center [C] the crimp tool between the edge of the connector and the dimple in the center of the connector.

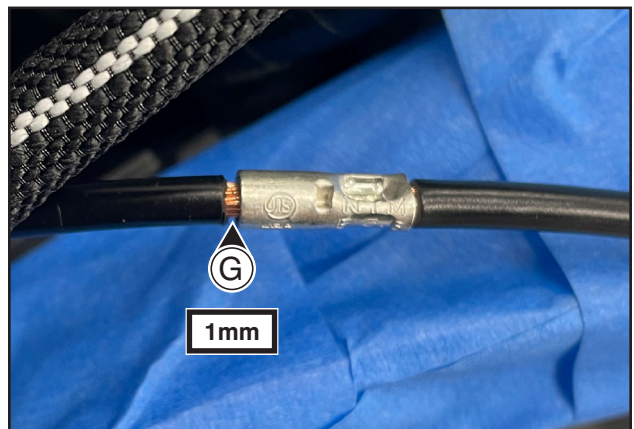
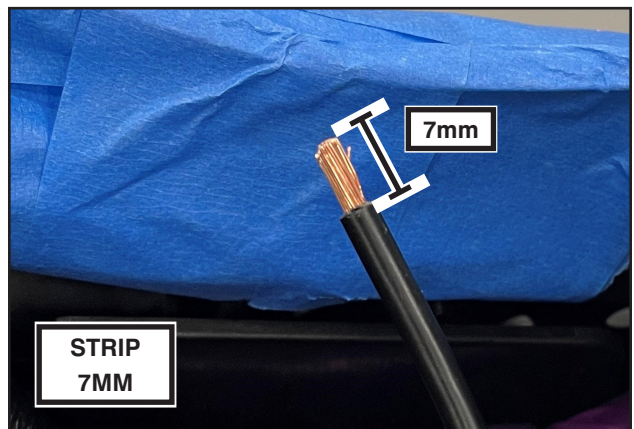
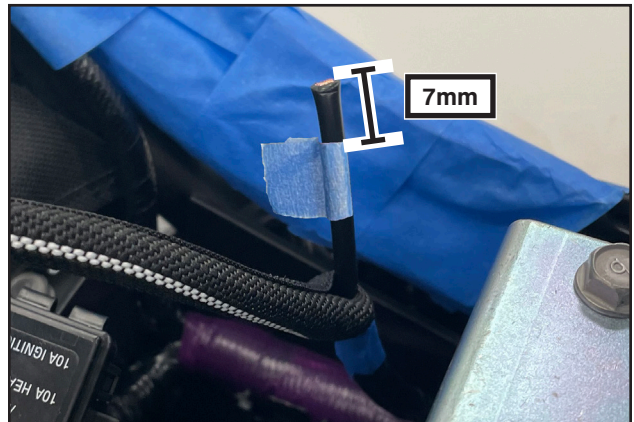

## Repair Procedure (continued)

### Replace Negative Lead Wire (continued)

- Crimp the new lead wire to the existing wire with the 5.5 mm jaw.

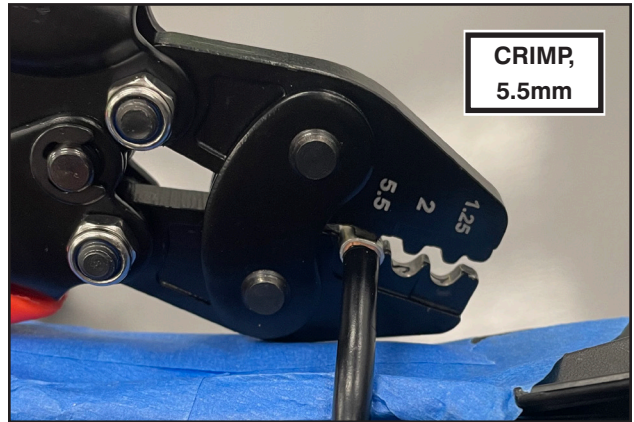

- Pull on the lead wire on each side of the connector to verify that the connection is secure.

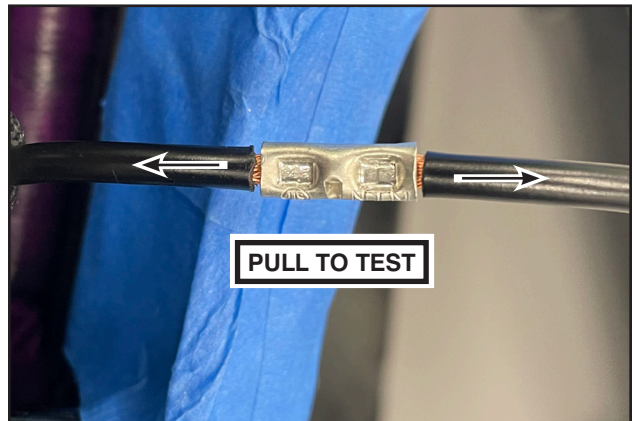

- Place the sleeve connector on the center of the tape (protector).
- Refer to the photo to position the long and short edges of the tape correctly.

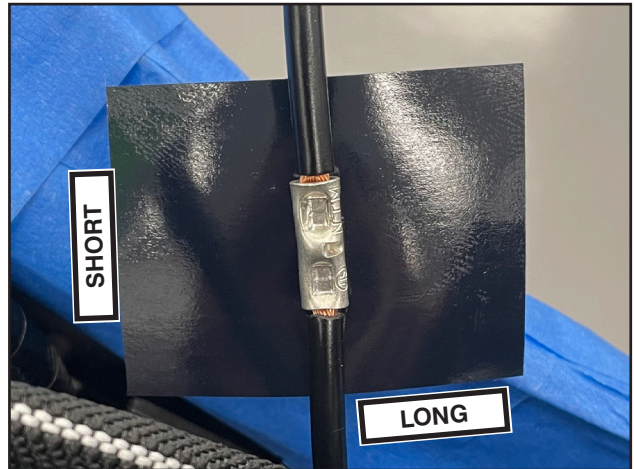

- Fold the tape in half and stick it together.



## Repair Procedure (continued)

### Replace Negative Lead Wire (continued)

- Wrap the tape [T] around the wire lead and secure with a small piece of vinyl tape [V].

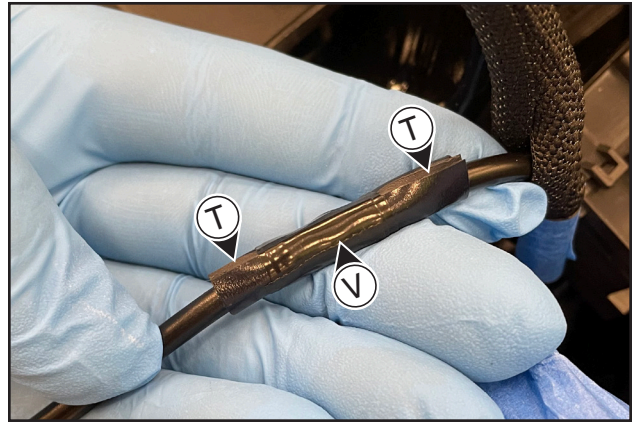

- Insert the wire lead back inside the slotted loom [L].

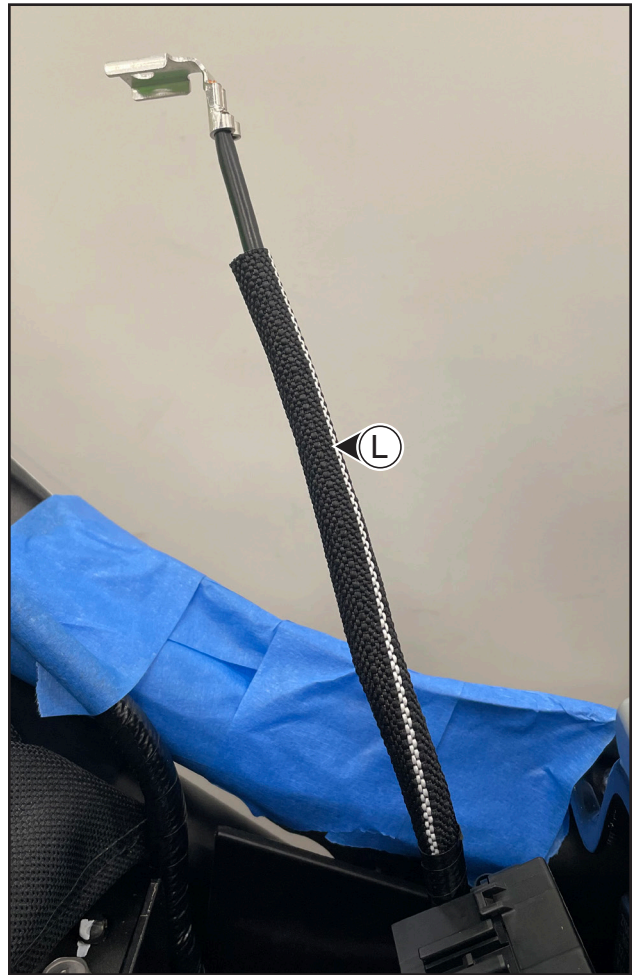

## Repair Procedure (continued)

### Replace Negative Lead Wire (continued)

- Begin wrapping with vinyl tape 20mm from the edge of the slotted loom.

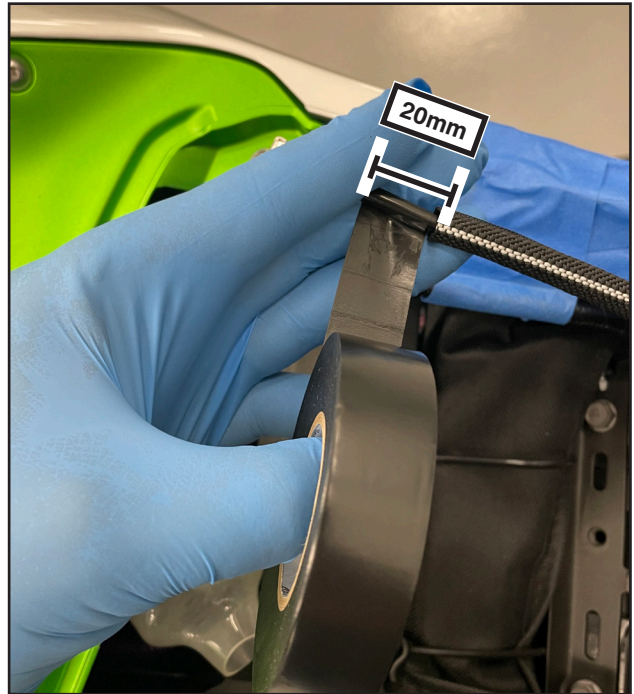

- Make sure to overlap a half of the tape or more



- Continue wrapping with vinyl tape up to the original tape on the lead wire and overlap by 20mm.
- Negative lead repair complete.
- Perform repair on positive lead beginning on next page.

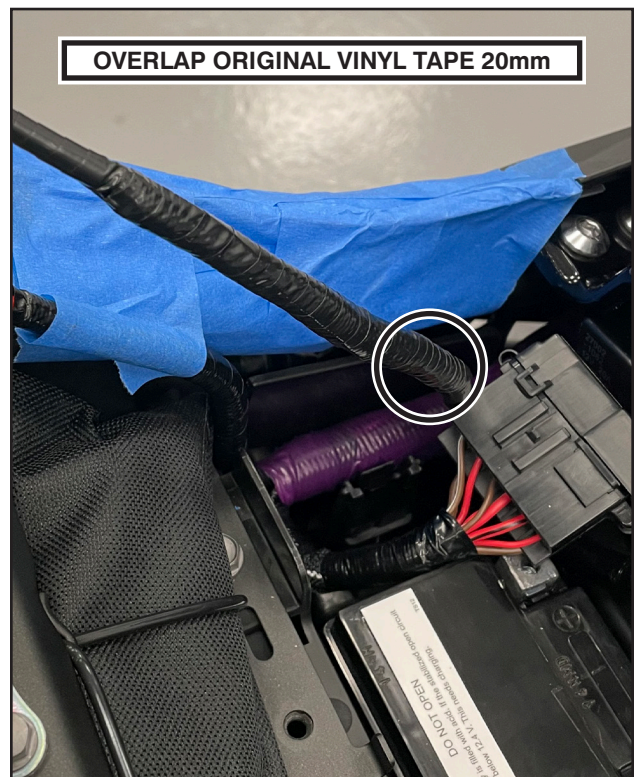

## Repair Procedure (continued)

### Replace Positive Lead Wire

- Measure 100mm from terminal end and mark with a piece of tape.

#### NOTE:

- o *Be careful not to cut the mesh wire loom or wires under the vinyl tape.*

- Carefully cut and peel back 100mm of the vinyl tape [T] from positive lead connector wire making sure to avoid cutting the underlying mesh wire loom [L].

#### NOTE:

- o *Be careful not to cut the mesh wire loom [L] under the vinyl tape.*

- Remove the positive lead wires from the mesh wire loom [L] taking care not to damage the loom.
- Align the connector of the new lead wire with the original and tape them together as shown.

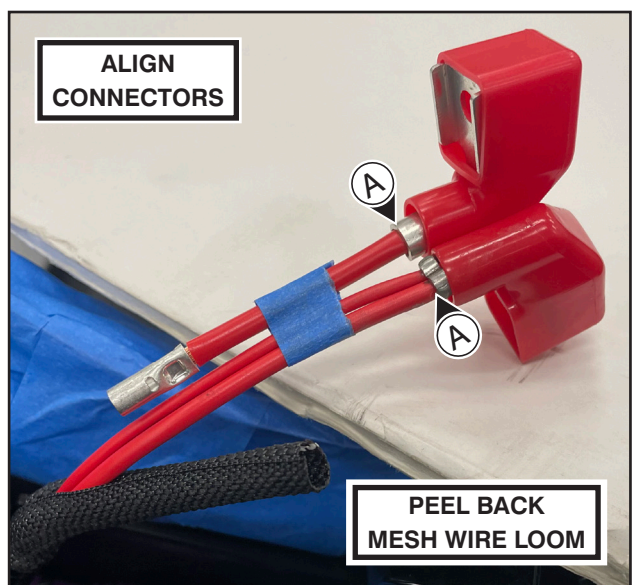
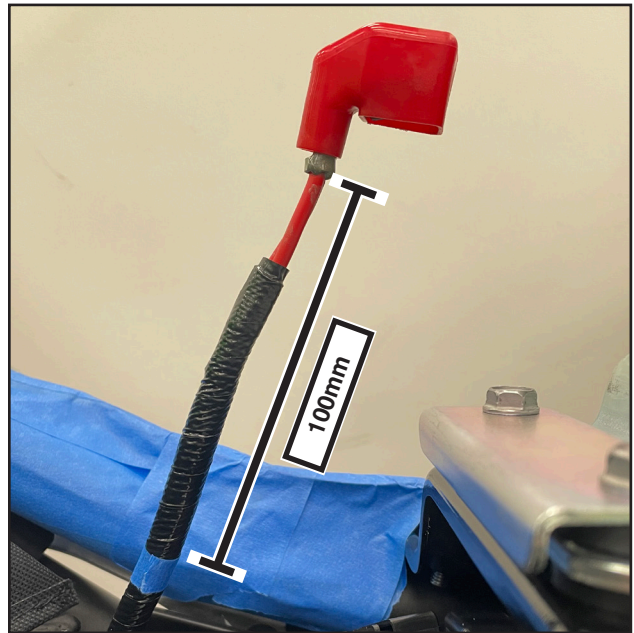

## Repair Procedure (continued)

### Replace Positive Lead Wire (continued)

- Cut the original positive lead wires even with the new connector as shown in the photo to the right.

#### NOTE:

- o Be careful not to cut the mesh wire loom.



- Measure 7mm from the end of the positive lead wires and mark with tape.
- Strip 7mm insulation from the lead wires.

#### NOTE:

- o Be careful not to damage the copper wire when stripping the insulation.

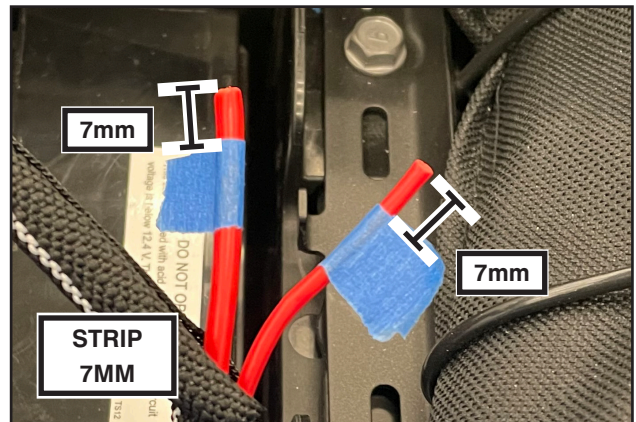

- Verify that the existing wires are stripped back 7mm.

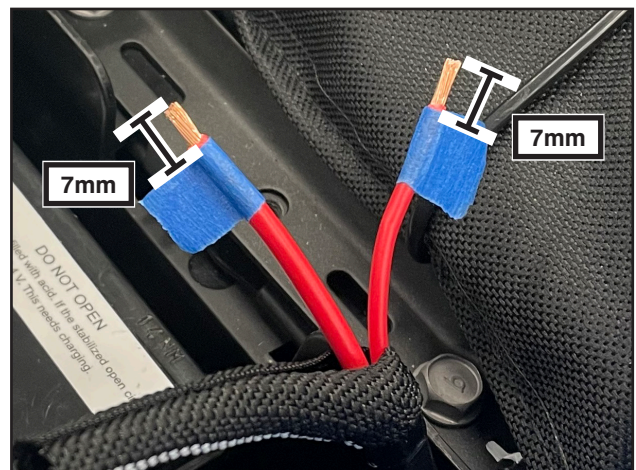

## Repair Procedure (continued)

### Replace Positive Lead Wire (continued)

- Twist the exposed wires together and insert into the connector of the new wire lead.
- Verify that a 1mm gap [G] exists between the connector and the insulation.

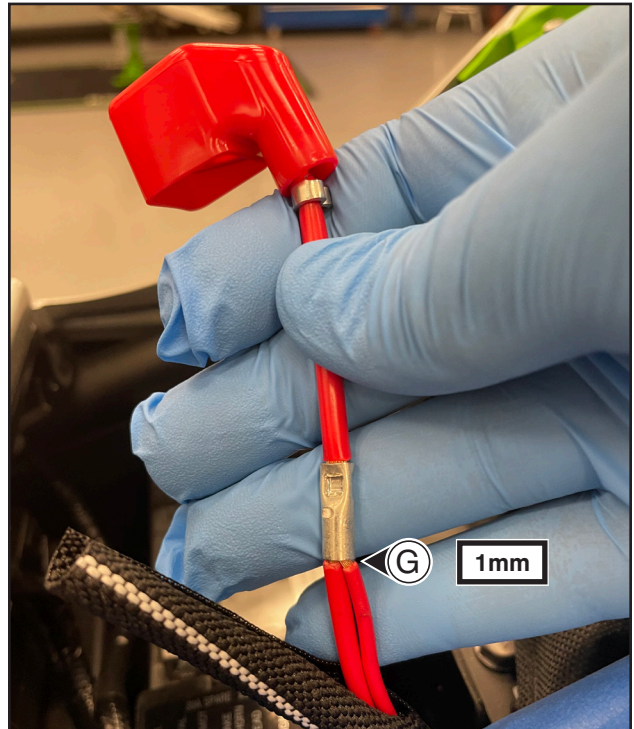

- Center [C] the crimp tool between the edge of the connector and the dimple in the center of the connector.



- Crimp the new lead wire to the existing wire with a 5.5mm crimp tool.



## Repair Procedure (continued)

### Replace Positive Lead Wire (continued)

- Pull to test the connection.

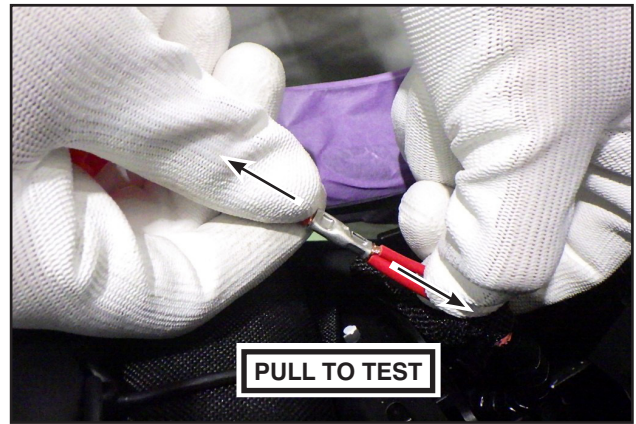

- Place the sleeve connector on the center of the tape (protector).
- Refer to the photo to position the long and short edges of the tape correctly.

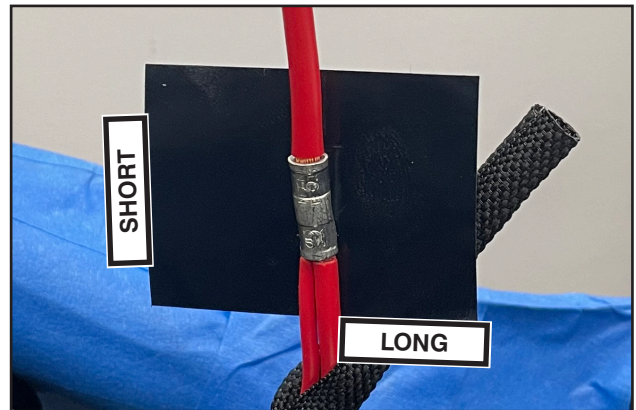

- Fold the tape in half and stick it together.

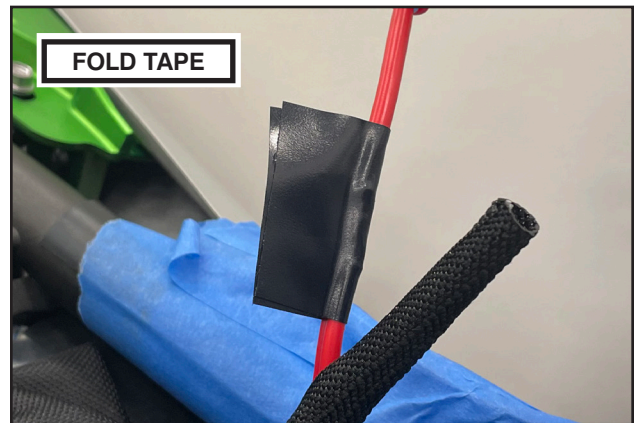

- Wrap the tape [T] around the wire lead and secure with a small piece of vinyl tape [V].

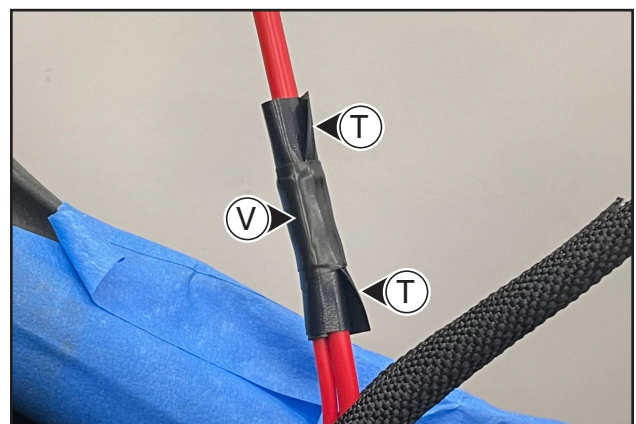

## Repair Procedure (continued)

### Replace Positive Lead Wire (continued)

- Insert the wire lead inside the slotted loom.
- Cover wire lead completely with slotted loom.



- Begin wrapping with vinyl tape 20mm from the edge of the slotted loom.

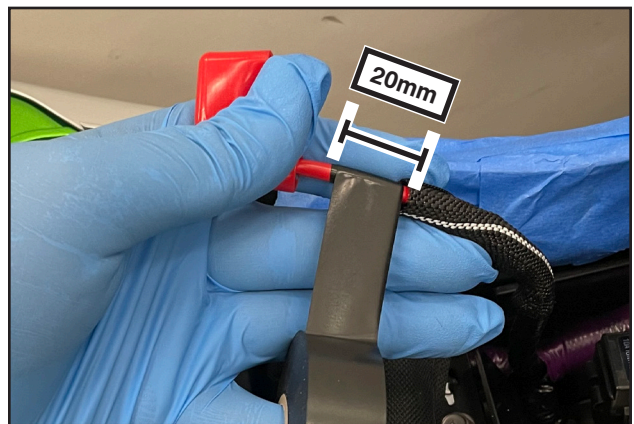

- Make sure to overlap a half of the tape or more



- Continue wrapping with vinyl tape up to the original tape on the lead wire and overlap by 20mm.



## Repair Procedure (continued)

### Replace Positive Lead Wire (continued)

- After repairing, apply white mark [M] on the KIT harness as shown in the picture to the right

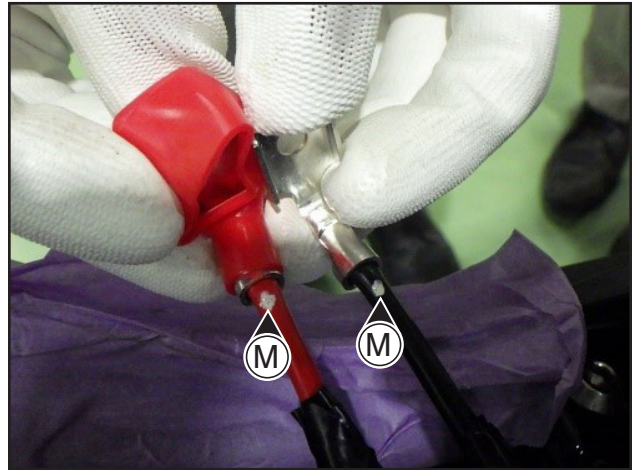

- Route each lead wire under the fuse box as shown in the picture to the right.

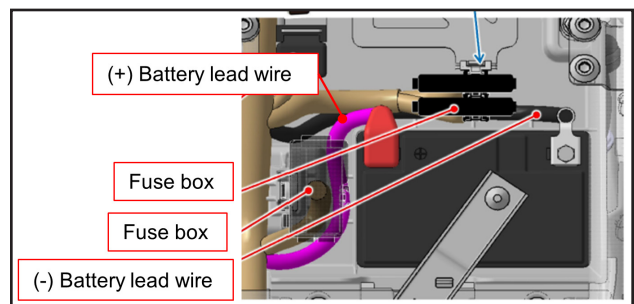

- Install fuse boxes [A] [B] [C].

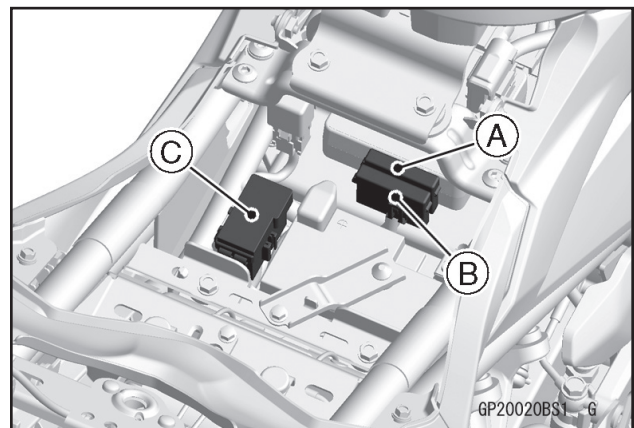

- Install Bolt [A], Bracket [B], Battery terminal [C], [D], and Battery [E]
- Remove masking tape from frame and bodywork.

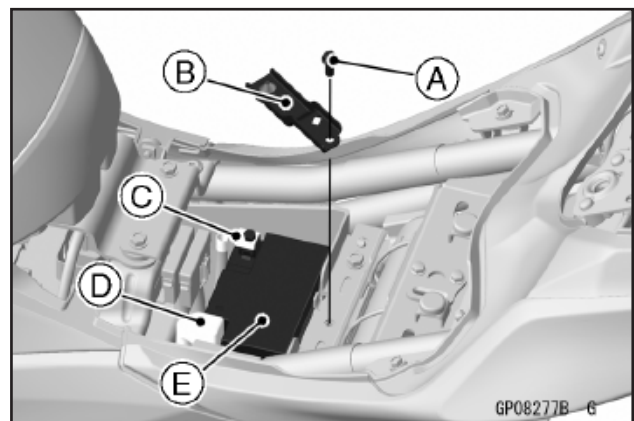

## Repair Procedure (continued)

### Replace Positive Lead Wire (continued)

- Turn ignition key on and check that 12V battery power is supplied.

#### NOTE:

- o Spare battery can be used for inspection.
- o Check that meter is operating as shown in the picture to the right.



#### NOTE:

- o If meter is not operating, check if the battery lead wires are properly connected with the battery.
- o If meter is still not operating, even if battery lead wires are connected with the battery, the battery lead wires may not be repaired properly.

## Warranty Information

This is a Factory Directed Modification. Repair is authorized regardless of ownership or warranty status.

Repairs **MUST BE PERFORMED IMMEDIATELY ON ALL ELIGIBLE UNITS** in the field and during initial assembly and preparation.

See the Warranty Policies and Procedures Manual (claim type 3 information) for detailed instructions when submitting the Warranty Claim.

### Verify eligibility using VIP in K-Dealer before starting the repair.

Please check VIP (Vehicle Information Portal) in K-Dealer for other possible repair campaigns for eligible units.

Procedure	Replace Battery Leads
Job Code	21438
Flat Rate Time	0.4 hrs
Claim Type	3
Part Number	99999-0933
Description	KIT, Wire Lead, MC24-05
Quantity	1
Sublet	Crimp Tool

## Repair Verification

Make a white paint mark [M] at the end of the frame number as shown to serve as repair verification.

#### NOTE:

- o Repair verification is an essential part of the repair procedure. Along with the physical repair verification, check VIP (Vehicle Information Portal) in K-Dealer for other possible repair campaigns for eligible units.

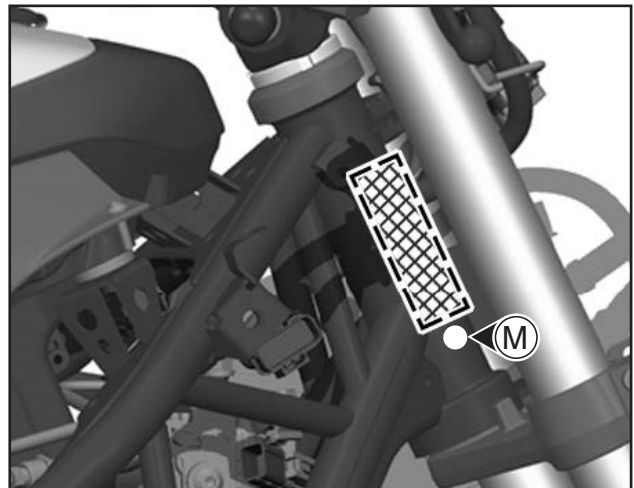

## 2024 Z e-1 ABS & NINJA® e-1 ABS BATTERY LEAD WIRE REPLACEMENT FACTORY DIRECTED MODIFICATION

Dear Kawasaki Motorcycle Owner:

At Kawasaki, we take pride in producing high quality products and are committed to your continued satisfaction. To maintain these standards, we have launched a service campaign to address a condition present on your motorcycle.

### **What is the reason for this notice?**

On certain eligible units, the 12V battery lead wire terminals may break off due to a faulty manufacturing process.

### **What Kawasaki and your dealer will do:**

At no cost to you, Kawasaki has authorized your dealer to replace the positive and negative battery lead wires. The repair will take approximately 30 minutes but may take longer due to scheduling at the dealership and the time needed to obtain required parts.

### **What should you do?**

Please call your Kawasaki dealer to schedule an appointment to have your motorcycle inspected. Please have your Vehicle Identification Number (VIN) ready when calling to schedule the appointment. To locate the nearest authorized Kawasaki motorcycle dealer, please visit [www.kawasaki.com](http://www.kawasaki.com) and click on the "LOCATE DEALER" link.

### **Can we assist you further?**

If you have questions or concerns that your dealer is not able to resolve, please contact Kawasaki's Customer Care Department at (866) 802-9381 (toll-free) between 7:00 a.m. and 4:00 p.m. PT Monday through Friday. Please have your Vehicle Identification Number ready when calling.

### **What if you no longer own this vehicle?**

Our records indicate you are the current owner of the 2024 Z e-1 ABS or NINJA e-1 ABS described in this letter. If you no longer have the vehicle described in this letter, please help us to update our records at [www.kawasaki.com](http://www.kawasaki.com) by clicking on "OWNER CENTER => OWNER SUPPORT => UPDATE OWNER INFO" or by calling Kawasaki toll free at (866) 802-9381.

Thank you for your purchase of a Kawasaki product and we hope that this campaign will maintain your continued satisfaction.

Sincerely,

Kawasaki Motors Corp., U.S.A.