

2024 Land Cruiser Pre-Delivery Service (PDS)

Service Category General

Section Pre-Delivery Service

Market USA

Toyota Supports
 ASE Certification 

Applicability

YEAR(S)	MODEL(S)	ADDITIONAL INFORMATION
2024	Land Cruiser	

Introduction

Pre-Delivery Service (PDS) is a critical step in satisfying our new car customers. Customer feedback indicates the following areas deserve special attention when performing PDS:

- Careful inspection for paint chips/scratches and body dents/dings.
- Proper operation of electrical accessories.
- Interior cleanliness.
- Proper function of mechanical systems.

Customer retention and proper maintenance of vehicles are and have always been a major focus for Toyota. To help remind customers that regular service is essential to the proper maintenance of the vehicle, dealers are required to install a service reminder sticker prior to delivery. By doing this, customers will be reminded to return to your dealership for service. Your current service reminder sticker may be used. (See PDS Check Sheet item 8 of “Final Inspection and Cleaning.”)

This bulletin contains the PDS procedures that apply specifically to 2024 model year Land Cruiser vehicles. A universal PDS [Check Sheet](#) that contains PDS steps that apply to all 2024 model year Toyota vehicles has been developed. To properly perform a complete PDS, you must complete all procedures contained in this TSB as well as the universal PDS Check Sheet.

In addition, if the vehicle is stored for over 30 days, be sure to follow [Long-Term Vehicle Storage Guidelines](#).

2024 Land Cruiser Pre-Delivery Service (PDS)

Table of Contents

- [Warranty Policy](#)3
- [Warranty Information](#)3
- [Required Tools & Equipment](#)3
- [D/C Cut Fuse Installation](#)4
- [Front License Plate and Mounting Bracket Installation*](#)5
- [Check Torque of Wheel Fasteners](#)6
- [Tire Pressure Warning System \(TPWS\) Initialization](#)6
- [Seating Position Control ECU Initialization*](#)7
- [Head Unit System Reset](#)7
- [Customize ACC Function](#)7
- [Dealer Contact Information for Call Dealer Head Unit Function*](#)7
- [Navigation — Set Date & Time by GPS](#)7

*If applicable.

2024 Land Cruiser Pre-Delivery Service (PDS)

Warranty Policy

If the need for additional repairs or adjustment is noted during the PDS, the required service should be performed under warranty. Reimbursement will be managed under the warranty policy.

The Warranty Policy and Procedures Manual requires that you maintain the completed PDS Check Sheet in the customer's file. If you cannot produce a completed form for each retailed vehicle upon TMS and/or Region/Distributor audit, the PDS payment amount will be subject to debit.

An additional Repair Order completed in conjunction with normal PDS MUST have time punch/flags for service. If multiple repairs are performed, separate time flags MUST be punched for each repair.

Warranty Information

OP CODE	DESCRIPTION	MODEL	TIME	OFF	T1	T2
001013	Pre-Delivery Service (PDS)	Land Cruiser	1.0	-	-	-

Required Tools & Equipment

REQUIRED EQUIPMENT	SUPPLIER	PART NUMBER	QTY
Techstream ADVi*	ADE	TSADVUNIT	1
Techstream 2.0		TS2UNIT	
Techstream Lite		TSLITEPDLR01	
Techstream Lite (Green Cable)		TSLP2DLR01	

*Essential SST.

NOTE

- Only ONE of the Techstream units listed above is required.
- GTS+ software version 2023.04.003.02 or later is required.
- Additional Techstream units may be ordered by calling Approved Dealer Equipment (ADE) at 1-800-368-6787.

2024 Land Cruiser Pre-Delivery Service (PDS)

D/C Cut Fuse Installation

To minimize battery discharge during transportation and storage, the D/C cut fuse (30A) has been removed at the assembly plant and temporarily stored in the blank space of the relay block in the engine compartment. During PDS, reinstall the D/C cut fuse (30A) into its original location and confirm ALL related Diagnostic Trouble Codes (DTCs) are cleared.

Remove the D/C cut fuse (30A) from the blank space of the relay block in the engine compartment and install the D/C cut fuse (30A) in the relay block as shown.

Figure 1.

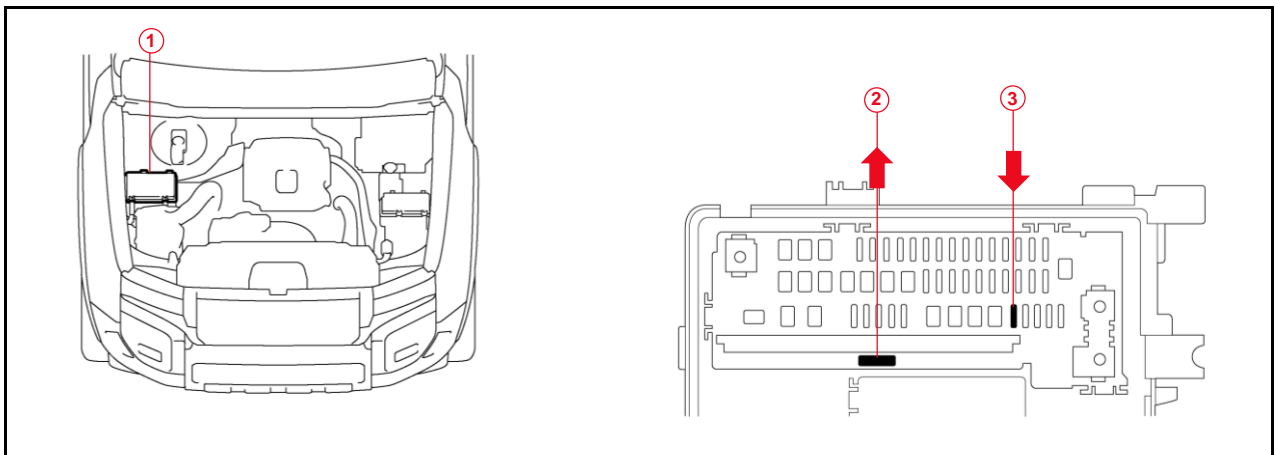

1	Relay Block
2	Remove the D/C Cut Fuse (30A)
3	Install the D/C Cut Fuse (30A) (Original Location)

NOTE

- With the D/C cut fuse (30A) removed, if ANY DTCs are detected when the ignition is turned ON during transportation, use Global Techstream Software (GTS+) to clear ALL DTCs AFTER ensuring that there are NO malfunctions.
- While the vehicle is stored at the dealership, disconnect the negative (-) battery terminal to prevent battery discharge. Refer to [T-SB-0024-23](#), *Battery Maintenance During PDS* for battery maintenance information.

2024 Land Cruiser Pre-Delivery Service (PDS)

Front License Plate and Mounting Bracket Installation

The front license mounting plate bracket and two self-tapping screws are loaded in the vehicle at the assembly plant. Follow this procedure to install the front license plate mounting bracket and front license plate in states where it is required by law.

1. Align holes "A" of the mounting bracket with the dimples on the front bumper.

NOTE

- Holes "A" are used for installation of the front license plate mounting bracket to the front bumper.
- Holes "B" are used to install the license plate onto the mounting bracket.

2. Screw the two self-tapping screws directly into the dimples to install the front license plate mounting bracket.

NOTICE

- Do NOT pre-drill holes in the dimples.
- Do NOT overtighten the self-tapping screws.

Figure 2.

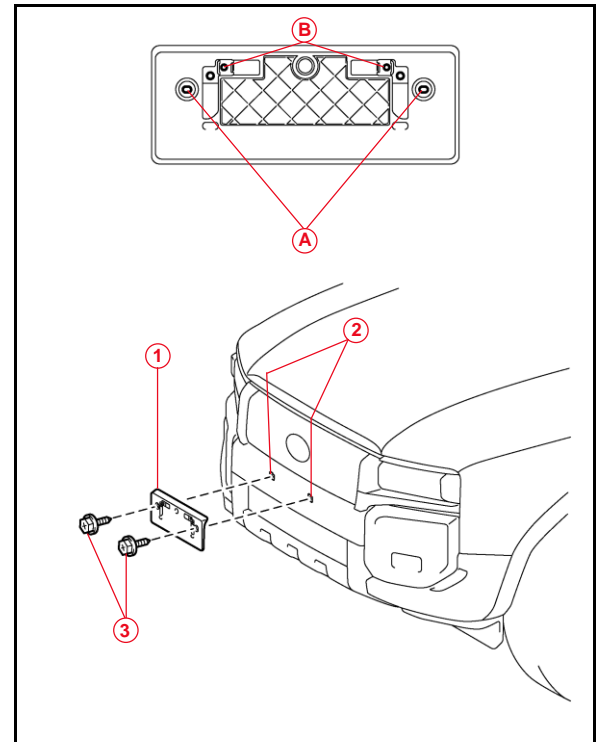

1	Mounting Bracket
2	Dimples
3	Self-tapping Screws

2024 Land Cruiser Pre-Delivery Service (PDS)

Front License Plate and Mounting Bracket Installation (continued)

3. Install the front license plate to the mounting bracket at holes "B" using two non-corroding bolts with the following dimensions:

Length: 15.0 mm (0.59 in.)

Diameter: 6.0 mm (0.24 in.)

Figure 3.

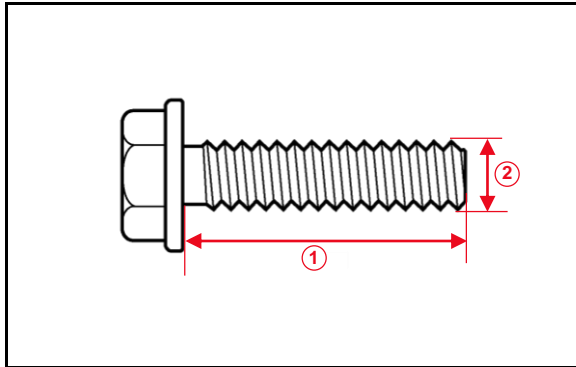

1	Length
2	Diameter

Figure 4.

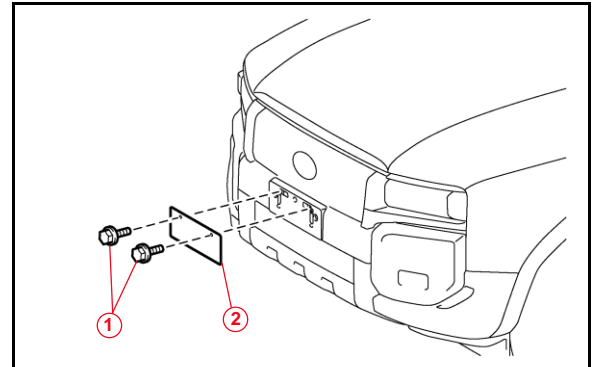

1	Bolts
2	Front License Plate

Check Torque of Wheel Fasteners

1. Refer to the applicable Repair Manual for the [specified torque](#) for the wheel fasteners.
2. Using a calibrated torque wrench, verify the wheel fasteners on each wheel are tightened to the specified torque listed in the Repair Manual.

Tire Pressure Warning System (TPWS) Initialization

Refer to the applicable Repair Manual for the TPWS [initialization procedure](#). Note the spare tire does have a TPWS sensor.

NOTE

To adjust the tire pressure correctly when the outside temperature is significantly colder than shop temperature, perform a Health Check using GTS+ and select the compensation tire pressure checkbox. Compensation pressures will display on the Health Check results screen. Adjust the tire pressure when the tires are cold.

2024 Land Cruiser Pre-Delivery Service (PDS)

Seating Position Control ECU Initialization

Refer to the applicable Repair Manual for the seating position control ECU [initialization procedure](#) (procedure 2).

Head Unit System Reset

Prior to vehicle delivery, please confirm that the welcome screen with language options appears on the head unit display when ignition is switched to the ON position. There may be instances where the welcome screen with language options may not properly appear on the head unit display.

If the welcome screen showing language options is not displayed, complete the following steps:

1. Select the Settings option (gear icon).
2. Scroll down and select the Info & Security option.
3. The System Reset dialogue box will appear. Select Reset to confirm the resetting of system.
4. Confirm that the welcome screen with language options is now displayed.

Customize ACC Function

The pre-startup function detects when a user enters the vehicle and energizes the audio head unit (+BA) so that the multimedia system can quickly be used. This function is not enabled at the factory to reduce parasitic current draw in transit and storage. To enable this function, it is necessary to set the ACC customization function in the navigation display to OFF.

1. Turn the engine switch (power switch) to the ON position (ON mode).
2. Enter the following menus: *Settings – Vehicle Customization – Utility – ACC Customize*.
3. Change the setting to OFF.

Dealer Contact Information for Call Dealer Head Unit Function

Refer to the *Multimedia System Owner's Manual* to [add dealer contact information](#).
See section 2-8 *Vehicle settings – Setting dealer information*.

Navigation — Set Date & Time by GPS

Prior to vehicle delivery, it is necessary to turn the Set Date & Time by GPS setting to the ON position.

1. Turn the engine switch (power switch) to the ON position (ON mode).
2. Navigate the following menus in the head unit: *Settings – General – Date & Time – Set date & time by GPS*.
3. Ensure the Set Date & Time by GPS function is set to the ON position.