



GROUP
Product Improvement

MODEL
See Model List
on Page 1

NUMBER
PI1802Y/Z (Rev 7, 03/22/2024)

DATE
March 2020

PRODUCT IMPROVEMENT CAMPAIGN

**SUBJECT: ENGINE REPLACEMENT INSTRUCTIONS
FOR DTC P1326 (PI1802Y/Z)**

* NOTICE

This bulletin has been revised to include additional information. New/revised sections of this bulletin are indicated by a black bar in the margin area.

This bulletin provides information related to the Technical Service Bulletin previously published [PI1802](#) titled "Knock Sensor Detection System - ECU Logic Improvement" equipped w/THETA II engine. Specifically, this bulletin provides instructions on which procedures to follow if, after installation of the KSDS, any one of the subject vehicles below returns to the dealer with Diagnostic Trouble Code (DTC) P1326 (Knock Signal Range/Performance).

Model List:

Year	Model	Engine	Production Date
2014	Optima (TF)	2.4L GDI	8/29/13 – 4/25/14
2015-2018	Optima (TF/QF/JF/JFa)	2.4L & 2.0L T-GDI	4/16/14 – 7/11/18
2014-2018	Sportage (SL/QL)	2.4L & 2.0L T-GDI	9/30/13 – 4/5/18
2015-2018	Sorento (XMa/UMa)	2.4L & 2.0L T-GDI	1/3/14 – 3/7/18

If DTC P1326 is present, first perform the bearing clearance inspection with the Engine Bearing Clearance Tester device (SST KQ231-2T110QQK). This device checks the rod bearing clearance by placing air and vacuum into the cylinder block. Measure the bearing clearance and follow the instructions in this bulletin. Refer to the flow charts found on page 2, then follow the appropriate procedure as outlined in this bulletin.

A [Vehicle Diagnosis Number \(VDN\)](#) must be created with or without DTC P1326 after scanning for DTCs, prior to performing PI1802Y/Z. If a VDN is not created, Warranty claim submission issues **WILL** occur.

Before conducting the procedure, verify the vehicle is included in the list of affected VINs.

* NOTICE

To ensure complete customer satisfaction, always remember to refer to KDealer+ Warranty Coverage (validation) Inquiry Screen (Service → Warranty Coverage → Warranty Coverage Inquiry) for a list of any additional campaigns that may need to be performed on the vehicle before returning it to the customer.

Printed TSB copy is for reference only; information may be updated at any time.
Always refer to KGIS for the latest information.

Circulate To: General Manager Service Manager Parts Manager
 Service Advisors Technicians Body Shop Manager Fleet Repair

Main Flowchart:

Note: Certain limitations may apply to this Product Improvement Campaign coverage. Refer to **Warranty Bulletin 2020-26** for more details.

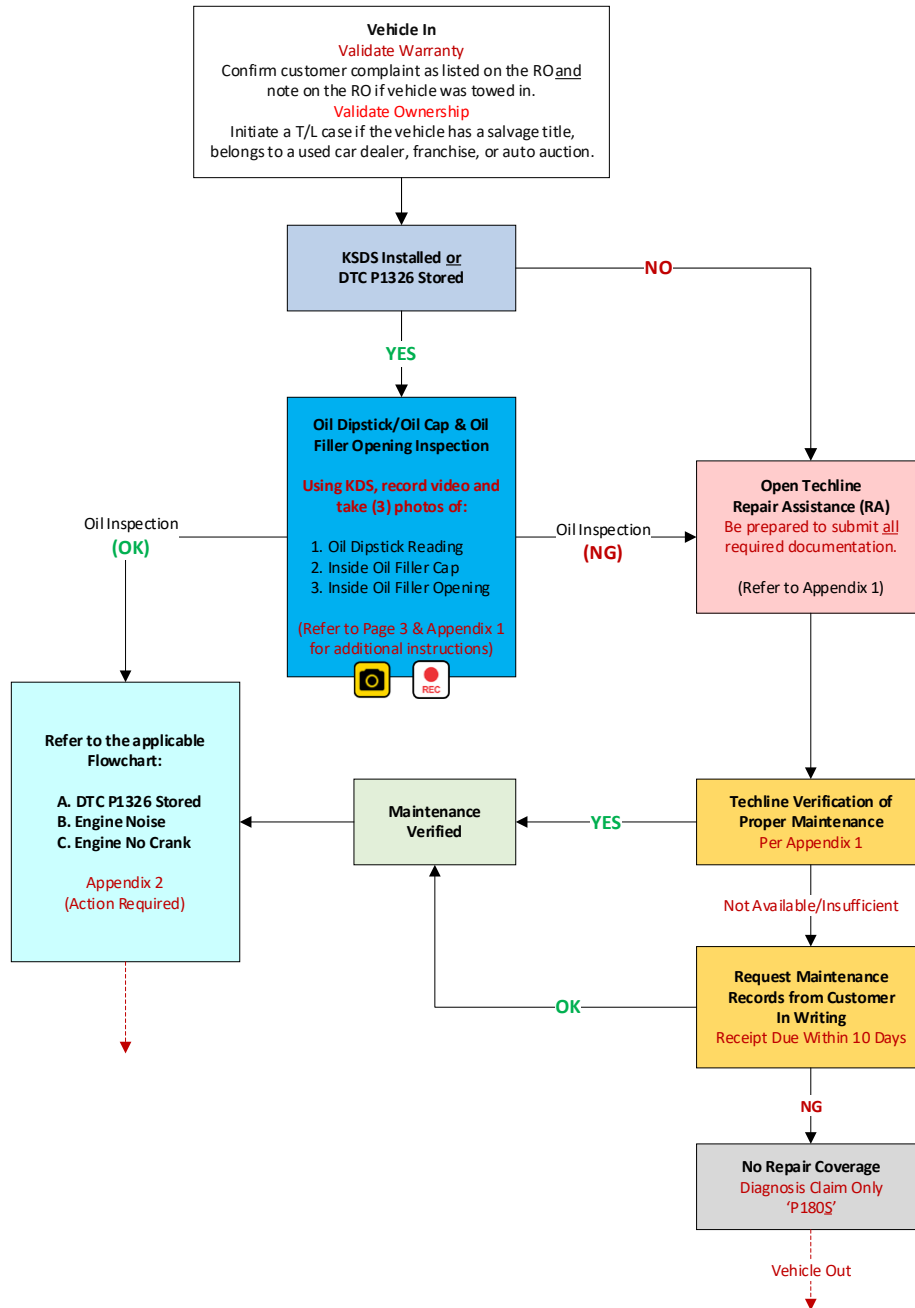

Follow the applicable flowchart upon documenting customer complaint for one (1) of the three (3) following concerns from Main Flowchart:

- A. DTC P1326 Stored... (Page 4)
- B. ENGINE NOISE... (Page 5)
- C. ENGINE, NO CRANK... (Page 6)



SUBJECT: ENGINE REPLACEMENT INSTRUCTIONS FOR DTC P1326 (PI1802Y/Z)

Oil Condition and Oil Level Inspection: (Main Flowchart)

1. Start video showing vehicle and move in towards the dash VIN tag.
2. Measure and record oil dip stick level.
3. Note oil dip stick reading on the RO.
4. Take a picture of the oil reading on dipstick.
5. Inspect the inner/bottom of the oil cap and inside oil filler opening.
6. Take a picture of both, the bottom of the oil cap and oil filler opening.



Record/Note findings: No oil, oil sludge, varnish, burnt oil smell condition(s) found.

*** NOTICE**

If NO oil is registered on the dipstick, or oil lacquering, oil sludge and/or oil varnish is present (NG), then the engine is therefore suspect to maintenance neglect. Review of the vehicle's maintenance history is required.

If suspect, proceed to the 'Oil Level Measurement' instructions below **and** submit with the Techline case.

Oil Level Measurement: (Main Flowchart → PWA Request) NO OIL READING ON DIPSTICK

1. Remove oil filler cap, remove oil drain plug and drain oil into the measuring container SST067BUCK and check oil level.
2. Record oil level reading on the RO.
3. Take photo of the drained oil container using KDS and attach to warranty claim PWA request.

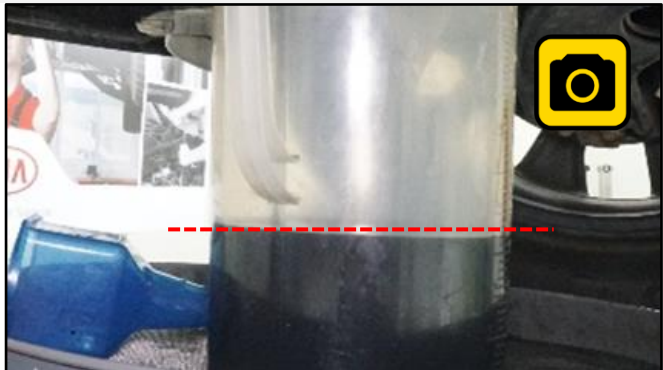

A. DTC P1326 Stored Create PI1802Y Claim – No Techline PWA Required

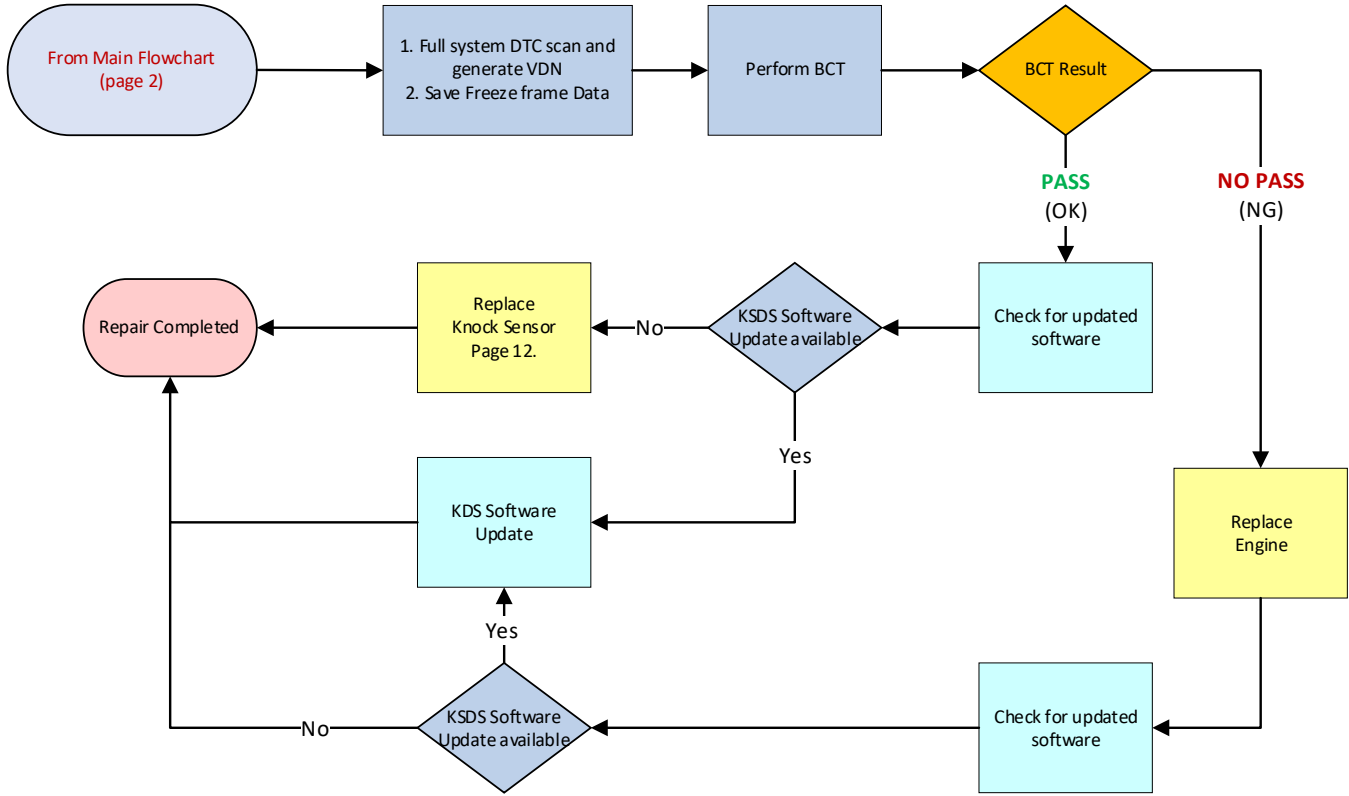

Note: If any concerns arise during/after completing the flowchart(s), open a Techline case online.

❗ IMPORTANT

Due to recent updates to KDS, always follow the BCT procedure instructions outlined in KDS. You may also refer to [SST067 for BCT Procedure/Calibration information](#).



B. Engine Noise

Techline PWA Required; Diagnosis Only Campaign Possible



Note: If any concerns arise during/after completing the flowchart(s), open a Techline case online.

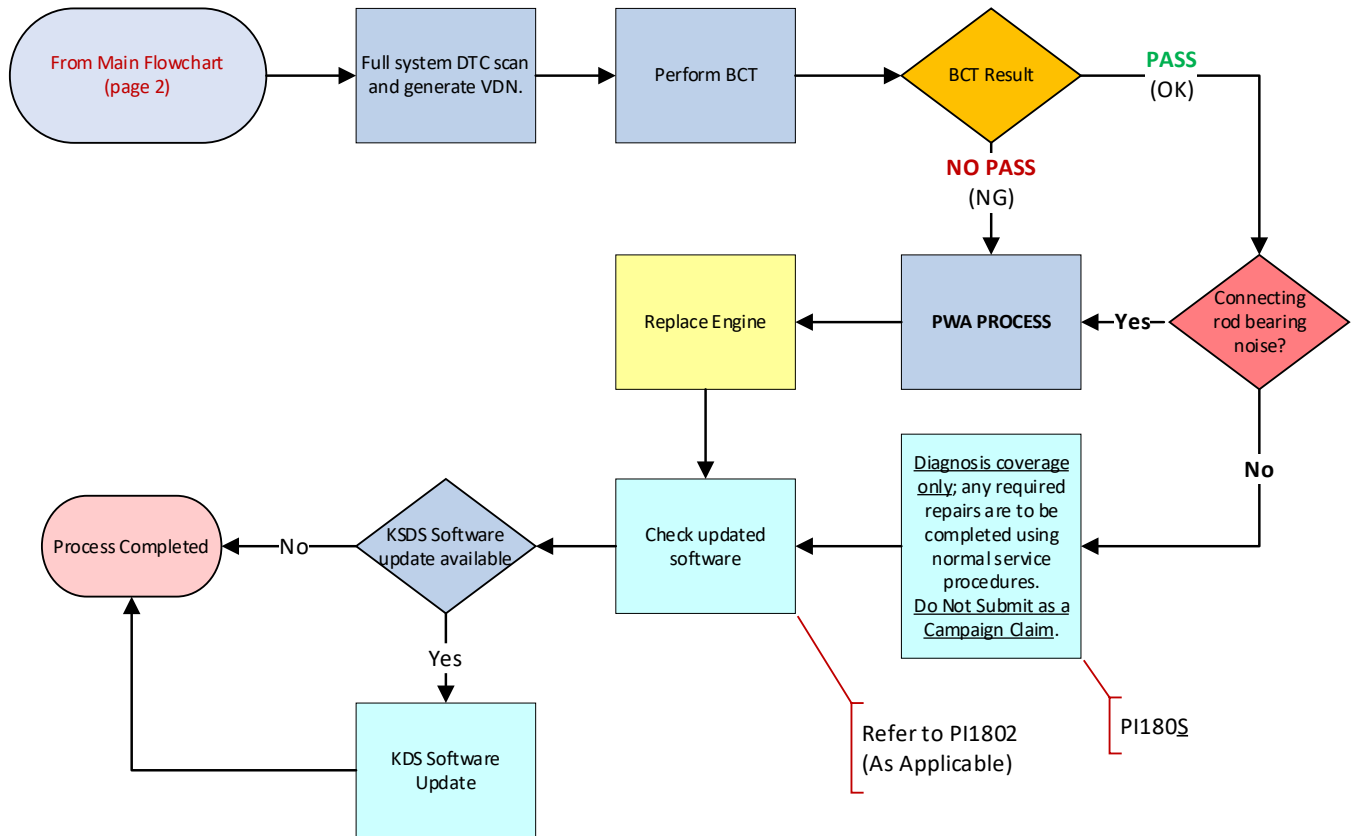

ⓘ IMPORTANT

Due to recent updates to KDS, always follow the BCT procedure instructions outlined in KDS. You may also refer to [SST067 for BCT Procedure/Calibration information.](#)



C. Engine No Crank

Techline PWA Required; Diagnosis Only Campaign Possible



Note: If any concerns arise during/after completing the flowchart(s), open a Techline case online.

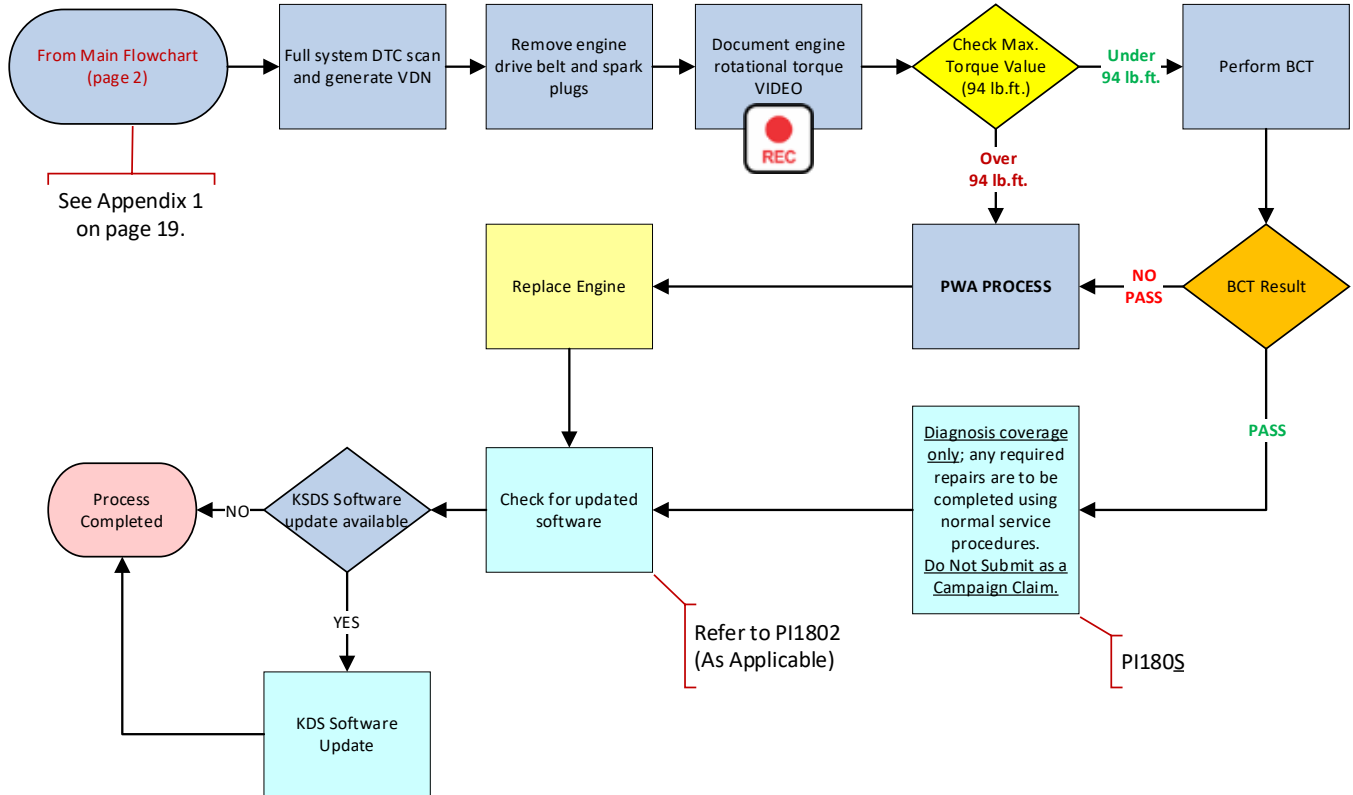

❶ IMPORTANT

Due to recent updates to KDS, always follow the BCT procedure instructions outlined in KDS. You may also refer to [SST067](#) for BCT Procedure/Calibration information.



SUBJECT: ENGINE REPLACEMENT INSTRUCTIONS FOR DTC P1326 (PI1802Y/Z)

Engine Replacement Procedure:

1. Remove the engine assembly by referring to the “Engine and Transmission (Transaxle) Assembly → Engine and Transmission (Transaxle) Assembly → Repair procedures” chapter in the applicable Shop Manual on KGIS.

Refer to [TSB ENG190](#) for information regarding engine replacement practices.



2. After removal of the engine from the vehicle, remove all components that will need to be transferred by referring to the applicable Shop Manual on KGIS.
3. Place the new engine block on an engine stand.
4. Install all removed components from the old engine block onto the new engine block utilizing all parts from Service Kit I and II. **Be advised of the following notes.**

Tightening torque for Knock Sensor:

13.7 – 17.4 lb.ft (18.6 – 23.5 N.m, 1.9 – 2.4 kgf.m)

Notes:

High Pressure Pump & Roller Tappet:

- Refer to [TSB ENG083](#) for special attention and handling procedures of GDI-specific components.
- When installing the high pressure pump and roller tappet onto the new engine, apply engine oil to the roller tappet, and O-rings of the high pressure pump.

Tightening torques of pump bolts:

**9.4 – 10.9 lb.ft (12.8 – 14.7 N.m,
1.3 – 1.5 kgf.m)**

Tightening torques of pipe flare nut:

**19.5 – 23.9 lb.ft (26.5 – 32.4 N.m,
2.7 – 3.3 kgf.m)**

**★ NOTICE**

Refer to [TSB ENG083](#) for gasoline direct injection (GDI) specific information, including related warnings and cautions for handling high fuel pressure system components.



High Pressure Fuel Pipe:

1. Properly position the new fuel pipe (A) and then hand-tighten both flare nuts (B).

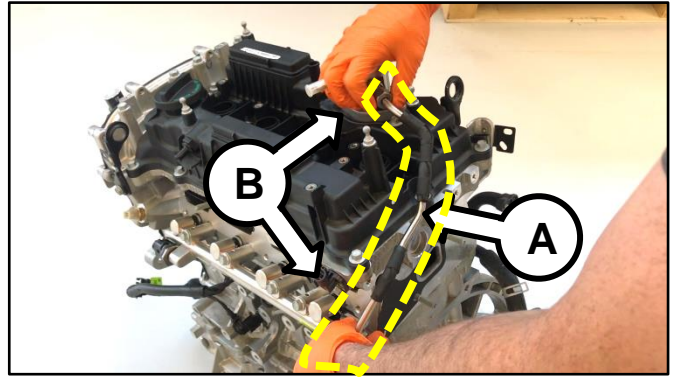

2. Install the pipe retaining bracket and bolt (C) and torque to specifications.

*** NOTICE**

If the bracket and bolt are missing, order and install a new bracket and bolt.

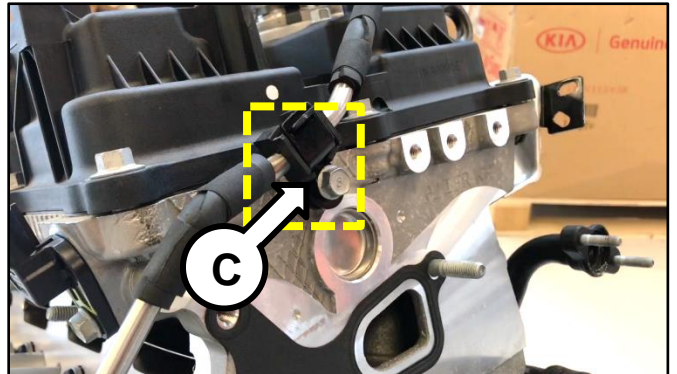

Tightening torque (bracket bolt):
5.8 – 8.7 lb.ft (7.8 –11.8 N.m,
0.8 – 1.2 kgf.m)

3. Using a click-type/electronic torque wrench and SST 09314-3Q100, torque both flare nuts (B) to specifications.

Tightening torque (flare nuts):
19.5 – 23.9 lb.ft (26.5 – 32.4 N.m,
2.7 – 3.3 kgf.m)

[Click here to see a video tutorial of high pressure fuel pipe install \(includes high pressure pump install\).](#)

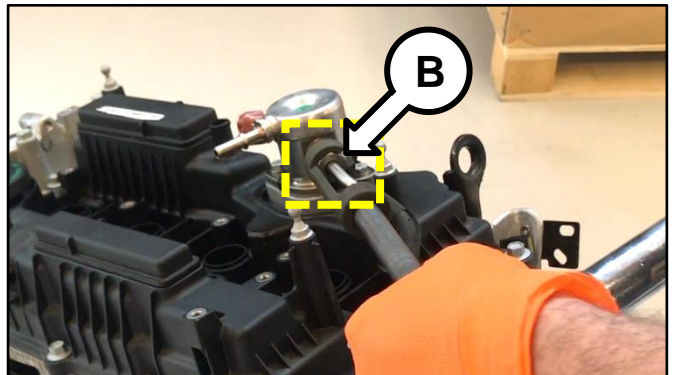
*** IMPORTANT**

The high-pressure fuel pipe bracket and bolt must be installed **AND** properly torqued prior to torquing the high-pressure fuel pipe flare nuts.

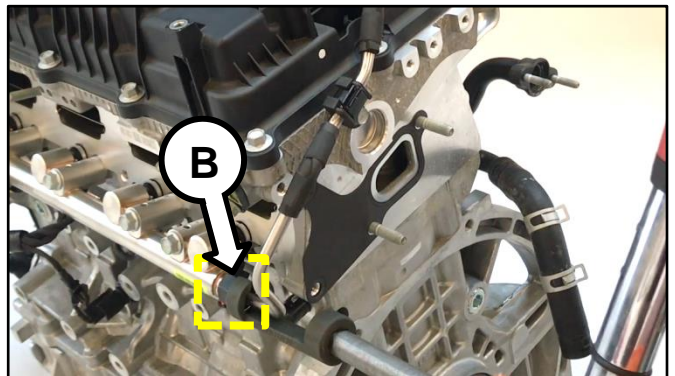

SUBJECT: ENGINE REPLACEMENT INSTRUCTIONS FOR DTC P1326 (PI1802Y/Z)

Delivery Pipe:

- Refer to [TSB ENG083](#) for special attention and handling procedures of GDI-specific components.
- Prior to installing the delivery pipe, be sure to replace all of the injector O-rings and injector retainers.
- Prior to installing the delivery pipe, apply engine oil to the injector O-rings.
- When installing the delivery pipe, use caution not to damage the tip of the injector.
- Be sure to replace the delivery pipe retaining bolts and torque them in the sequence shown.

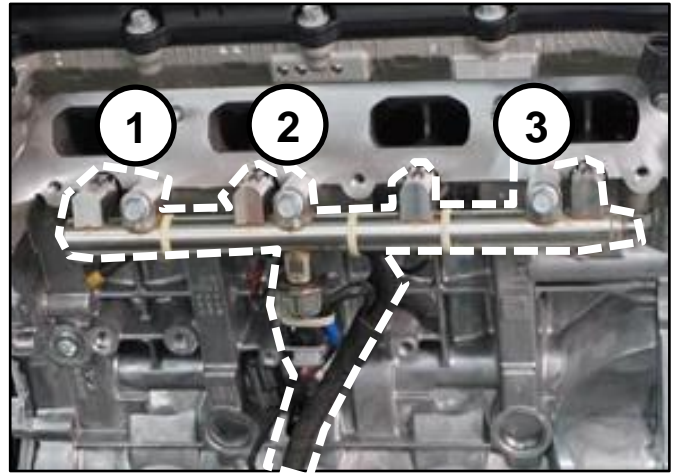
**Tightening torque of bolts:**

**13.7 – 17.4 lb.ft (18.6 – 23.5 N.m,
1.9 – 2.4 kgf.m)**

*** NOTICE**

Combustion seals must be compressed after installation and before attempting to install into the cylinder head. Use SST 09353 2B000 (refer to [TSB ENG083](#)).

Dipstick Tube & Dipstick:

- Prior to installing the new tube, lubricate the o-ring located at the bottom of the tube with engine oil.
- Install the red dipstick included in Service Kit I.

Tightening torque of bolt:

**5.8 – 8.7 lb.ft (7.8 – 11.8 N.m,
0.8 - 1.2 kgf.m)**

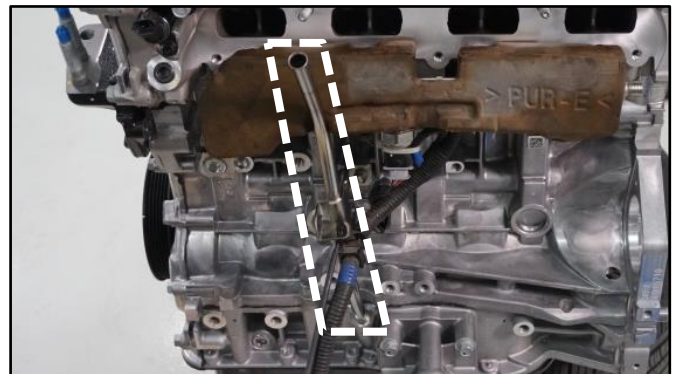

Intake Manifold:

- Prior to installation, replace the intake manifold gaskets.
- Torque bolts in the sequence shown.

Tightening torque of bolts:

**13.7 – 17.4 lb.ft (18.6 – 23.5 N.m,
1.9 – 2.4 kgf.m)**

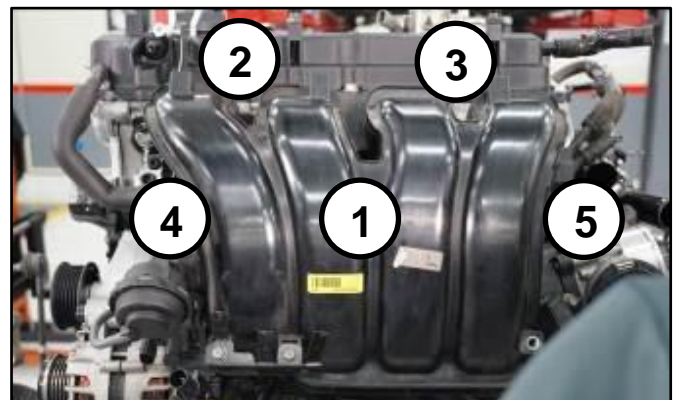

Exhaust Manifold:

- All engines supplied under this Product Improvement Campaign have the exhaust manifold studs configured for SULEV engines.
- Using the pictures to the right, check the exhaust manifold stud location and quantity. Relocate as required for ULEV engines and obtain one (1) extra from the removed engine.
- Prior to installation, replace the exhaust manifold gasket and front muffler gasket.
- Torque nuts in the sequence shown.

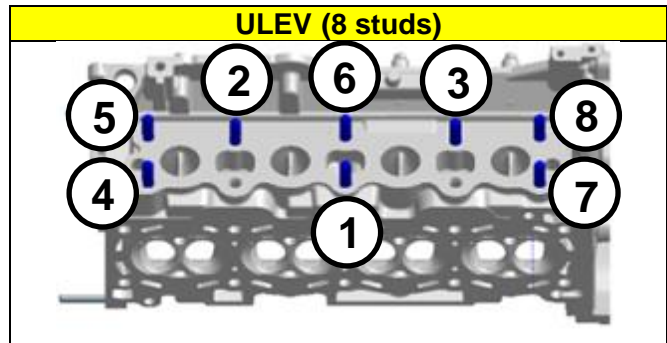
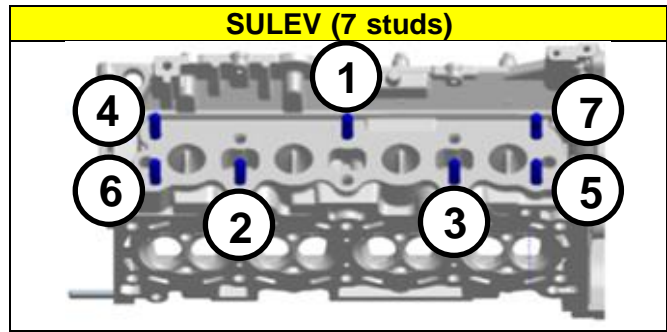

Tightening torque of nuts:
36.2 – 39.7 lb.ft (49.0 – 53.9 N.m,
5.0 – 5.5 kgf.m)

***For 15MY Sorento (XMa) vehicles only: check the underhood emissions label and record whether the label references ULEV or SULEV. This information is needed to select/order the correct replacement engine.**

	KIA MOTORS CORPORATION VEHICLE EMISSION CONTROL INFORMATION		
Conforms to regulations :		2015 MY	
U.S.EPA :	T2B5 LDV	OBD :	CA II Fuel : Gasoline
California :	ULEV PC	OBD :	CA II Fuel : Gasoline
Group :	EKMRV24APE	DFI/HO2S(2)/WU-TWC/TWC	
Evap. :	EKMRV0130CRE	No adjustments needed.	
[WARNING]		39417-20A02	A402
Loaded I/M testing of permanent four-wheel drive or traction control-equipped vehicles must be conducted on a four-wheel drive speed synchronized dynamometer. Otherwise, a non-loaded test procedure must be performed.			

- On Turbo engines, replace the turbocharger oil feed line and gaskets.

Tightening torque of oil feed line bolt:
8.7 – 13.0 lb.ft (11.8 – 17.7 N.m,
1.2 – 1.8 kgf.m)

Tightening torque of oil feed line nuts:
5.8 – 8.7 lb.ft (7.8 – 11.8 N.m,
0.8 – 1.2 kgf.m)

Tightening torque of oil drain line nuts and bolts:
5.8 – 8.7 lb.ft (7.8 – 11.8 N.m,
0.8 – 1.2 kgf.m)

- Torque exhaust manifold nuts in the sequence shown.

Tightening torque of nuts:
36.2 – 39.7 lb.ft (49.0 – 53.9 N.m,
5.0 – 5.5 kgf.m)

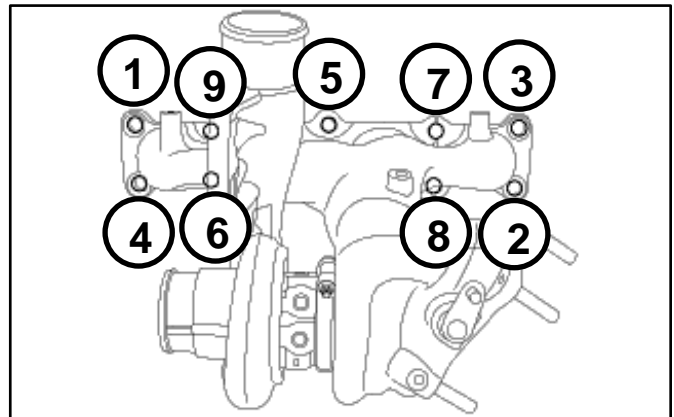

SUBJECT: ENGINE REPLACEMENT INSTRUCTIONS FOR DTC P1326 (PI1802Y/Z)
Oil Cooler Tube Assembly:

New engines may be supplied with a different oil cooler. Use steps below to determine the need for a replacement oil cooler tube assembly.

- If the new engine's (bigger) oil cooler (A) does not match the old engine's (smaller) oil cooler (B), replace the oil cooler tube assembly with the improved part. See parts table on page 16.
- If the new engine's (bigger) oil cooler (A) matches the old engine's (bigger) oil cooler (A), reuse the old engine's oil cooler tube assembly.
- If the new engine's (smaller) oil cooler (B) matches the old engine's (smaller) oil cooler (B), reuse the old engine's oil cooler tube assembly.

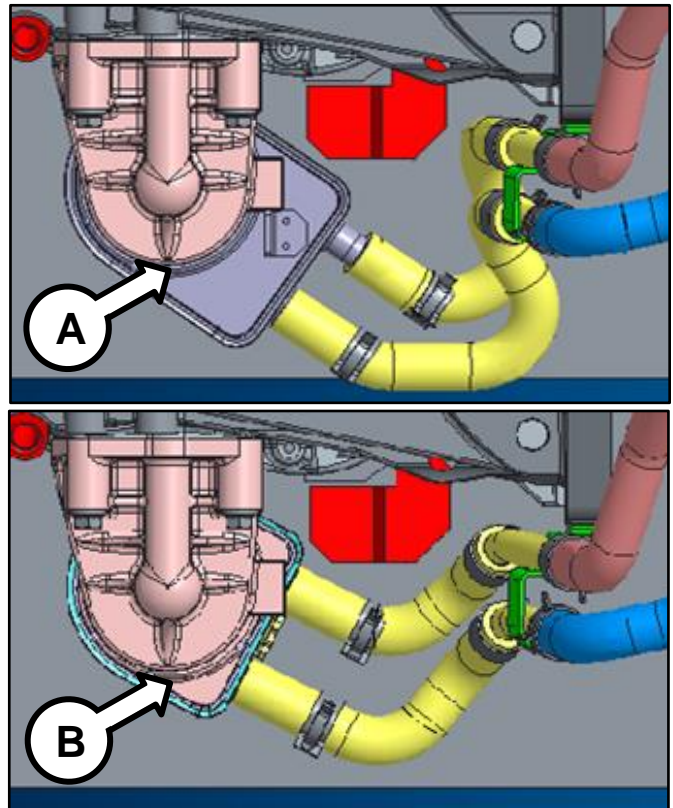
Drive Plate Bolts:

- Replace all seven (7) drive plate (AT) bolts.

Tightening torque of nuts:

**86.8 – 93.9 lb.ft (117.7 – 125.5 N.m,
12.0 – 13.0 kgf.m)**

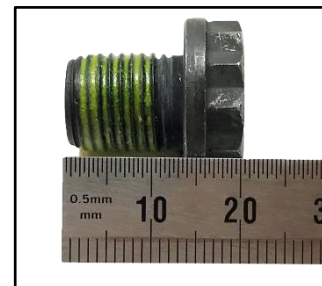

Drive Plate Bolt (A/T)

Torque Converter

- If the torque converter has moved from the fully inserted position, carefully push inward while rotating the torque converter until it is recessed approximately 9/16 – 5/8" (14 – 16mm) (☑) into the transaxle case when reinstalling the automatic transaxle.

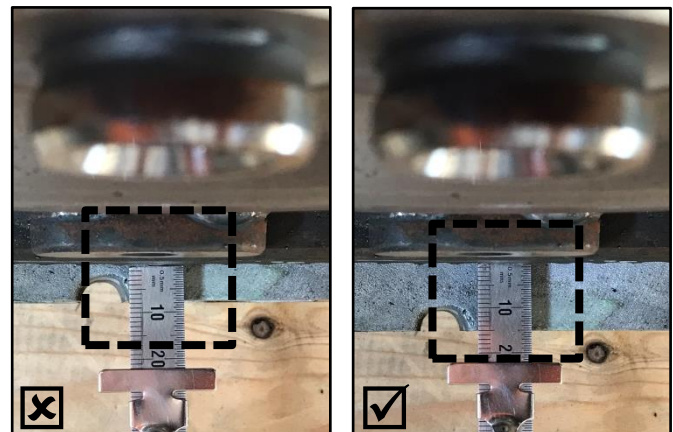

Not Fully Inserted

Fully Inserted



- Reinstall the assembled engine and transmission/transaxle into the vehicle.

Be sure to:

- Fill crankcase with 5W-30 oil (~5.8 quarts).
- Recommended Product: QUARTZ 9000 FUTURE FGC 5W-30 **Full Synthetic** SN PLUS, QUARTZ 9000 FUTURE XT 5W30 **Full Synthetic** SN PLUS, Mobil Super Synthetic 5W30 or above.
If not available, use other brand 5W30 and **Full Synthetic** type with API SN/SN+/SP, ILSAC GF4/GF5 or higher service grade.
- Fill and bleed the cooling system with 50/50 coolant or mixture appropriate for area.
- Pressurize the fuel system before starting the vehicle.
- Reset engine adaptive values and perform steering angle sensor calibration.

Refer to [TSB ENG190](#) for information regarding engine replacement practices.

- Confirm that the ROM ID is up-to-date. If not, reflash the ECU to the latest ROM ID available. Refer to [PI1802 – Knock Sensor Detection System ECU Logic Improvement](#)
- Verify proper operation of the vehicle with road test, and **with the engine ON (running), erase any stored DTCs** (e.g., EPS, ESC, and TPMS) that may have been set by this procedure. Verify no leaks exist and ensure engine oil and coolant are at their proper level.

If any DTCs are still active, follow any related diagnosis and repair as needed.

Knock Sensor Replacement:

- Ensure the ignition is 'OFF'.
- Disconnect the battery negative (-) terminal.
- Disconnect the knock sensor (A) connector.
- Remove the intake manifold by referring to the "Engine Mechanical System → Intake Manifold → Repair Procedure" chapter in the applicable Shop Manual on KGIS.
- Loosen the knock sensor (A) retaining bolt (B) and replace the knock sensor.

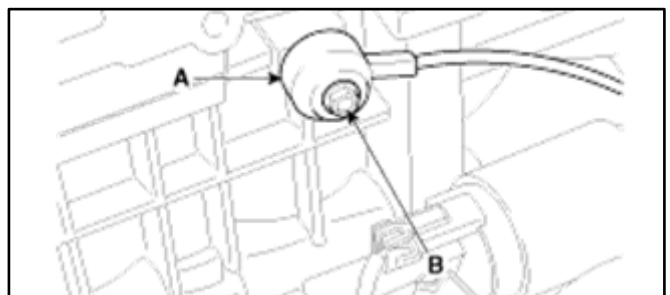
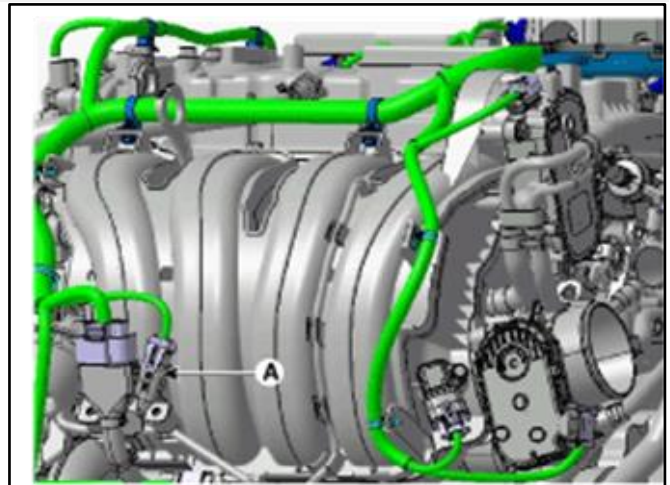

Torque Specification for bolt (B):

13.7 – 17.4 lb. ft. (18.6 - 23.5 N.m,
1.9 - 2.4 kgf.m)

Reinstall all removed parts in the reverse order of removal and confirm normal engine operation and no DTC's.

SUBJECT: ENGINE REPLACEMENT INSTRUCTIONS FOR DTC P1326 (PI1802Y/Z)
Additional Instructions for AWD (XMa) 2.4L models:

1. Remove the right front drive axle (A) by detaching the brake line and ABS retainer brackets (B) from the strut housing and knuckle then remove the two knuckle/strut retaining bolts (C).

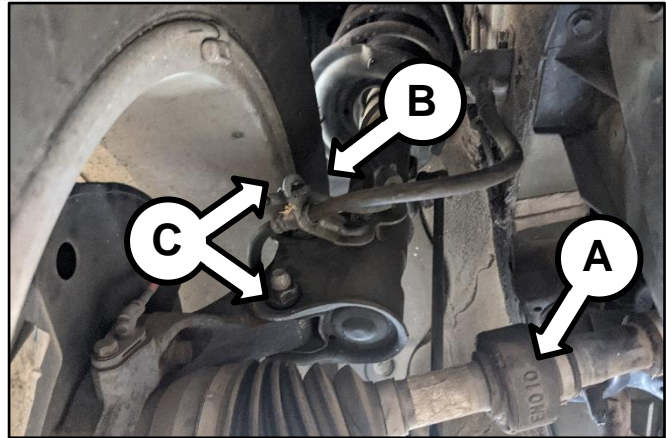

2. Remove the five (5) transfer case retaining bolts (D).

Note: Three (3) located on the bottom.

Refer to the chapter in the applicable Shop Manual on KGIS for torque specifications.

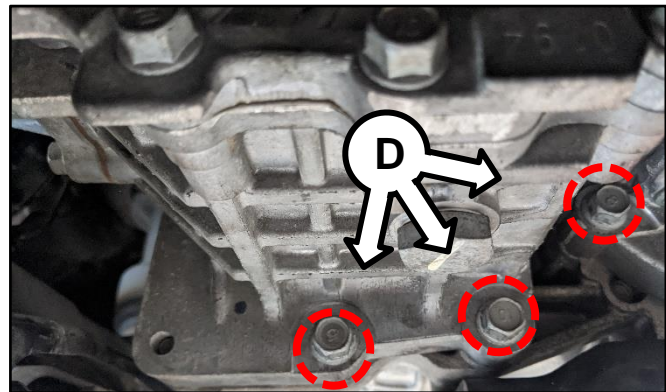

Note: Two (2) located on the top.

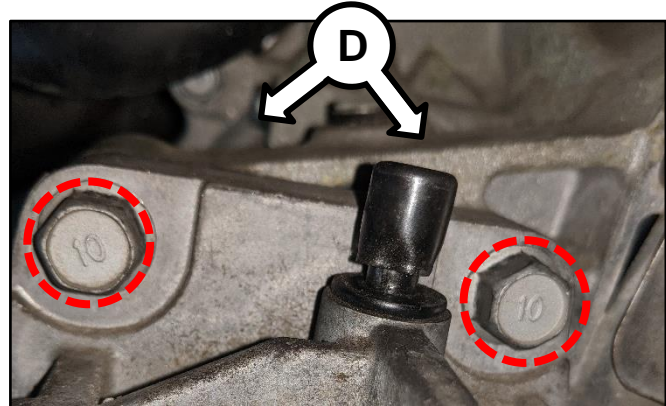

3. Remove the two (2) drive axle bracket retaining bolts (E).

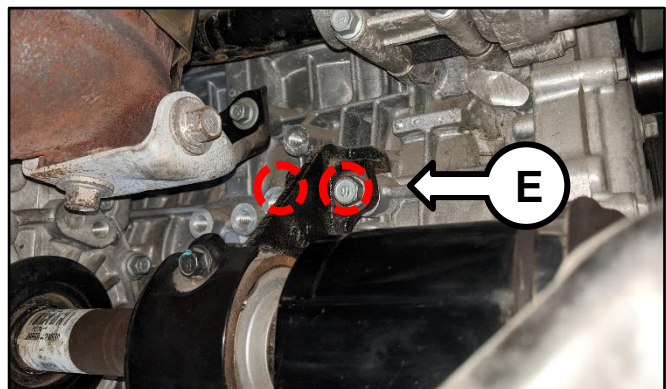

SUBJECT: ENGINE REPLACEMENT INSTRUCTIONS FOR DTC P1326 (PI1802Y/Z)

- Using a pry bar and rubber hammer, strike the axle where shown to release the right front drive axle (A).

Remove the right front drive axle (A) and set aside.

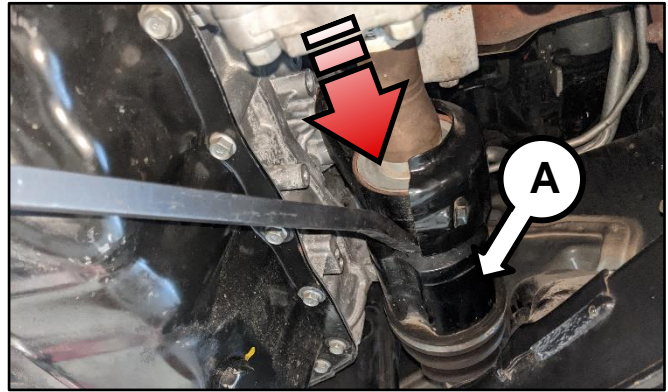

- Remove the four (4) rear driveshaft retaining bolts (F).

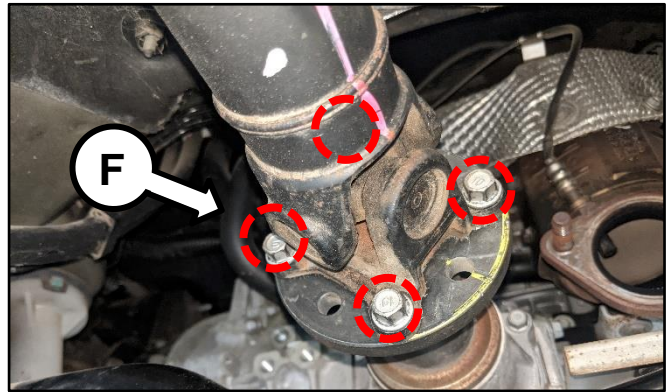

- Move the transfer case to the right for additional room to allow engine removal.

Additional Instructions for AWD (SL) 2.0L-T models:

- Remove the two (2) bottom damper retaining bolts (A).

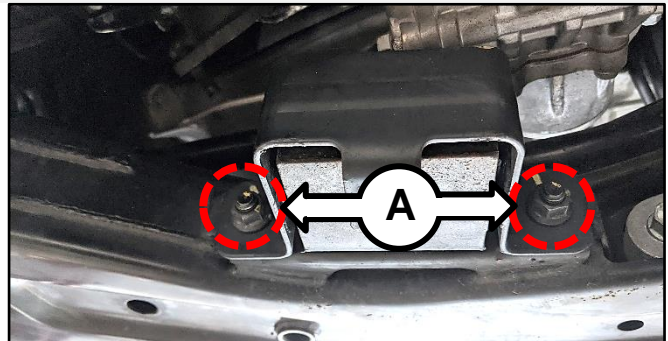

- Remove the five (5) transfer case retaining bolts (B).

Note: Two (2) located on the top.

Refer to the chapter in the applicable Shop Manual on KGIS for torque specifications.

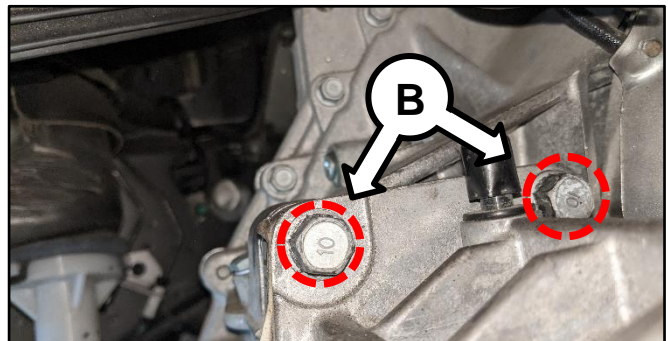

SUBJECT: ENGINE REPLACEMENT INSTRUCTIONS FOR DTC P1326 (PI1802Y/Z)

Note: One (1) located on the bottom left.

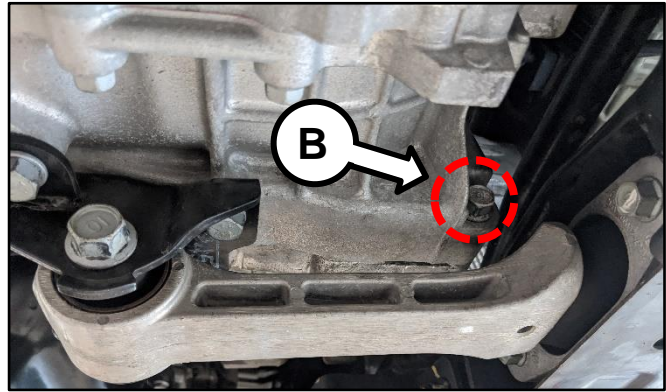

Note: Two (2) located on the bottom right.

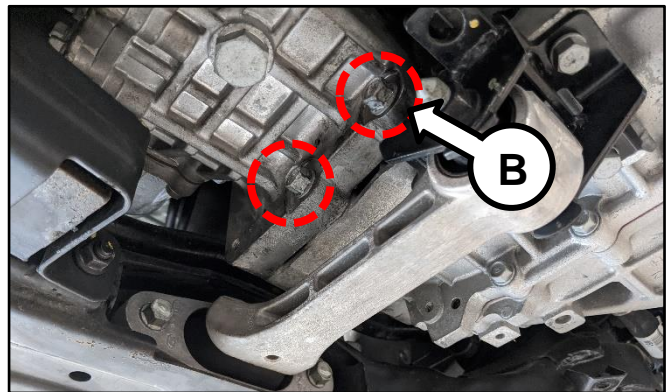

3. Remove the two (2) drive axle bracket retaining bolts (C).

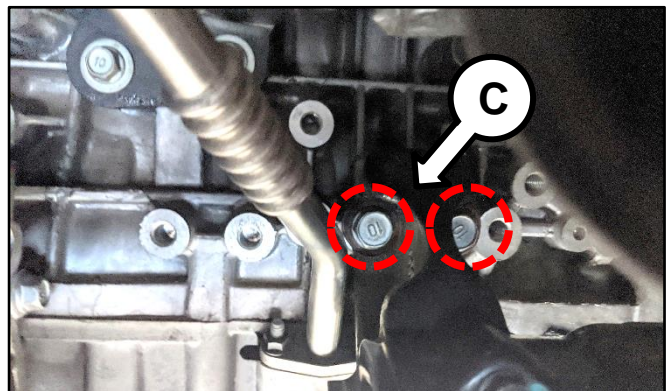

4. Remove the four (4) rear driveshaft retaining bolts (D).

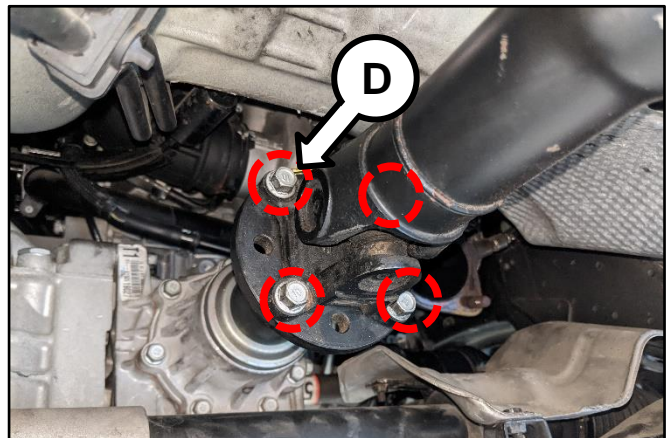

5. Move the transfer case to the right for additional room to allow engine removal.







SUBJECT: ENGINE REPLACEMENT INSTRUCTIONS FOR DTC P1326 (PI1802Y/Z)

AFFECTED VEHICLE RANGE:

Model	Production Date Range
14MY Optima (TF)	August 29, 2013 through April 25, 2014
15-18MY Optima (TF/QF/JF/JFa)	April 16, 2014 through July 11, 2018
14-18MY Sportage (SL/QL)	September 30, 2013 through April 5, 2018
15-18MY Sorento (XMa/UMa)	January 3, 2014 through March 7, 2018

REQUIRED TOOL:

Tool Name	Tool Part No.	Figure	Comments
Torque Wrench Socket	09314 3Q100		Refer to TSB ENG083 for detailed usage instructions
Injector Combustion Seal Ring Installer	09353 2B000		
Click-Type or Electronic Torque Wrench	N/A		Locally Sourced
Bearing Clearance Tester Kit	KQ231 2T110QQK		Auto-shipped to Dealers For troubleshooting assistance, contact the GITA Support Line at: (888) 542-4371. For replacement parts, refer to SST067 or contact Snap-On Tools at: (888) 542-1011.
Oil Measurement Container	SST067BUCK		Auto-shipped to dealers in December 2020. For replacement parts, contact Snap-On Tools at: (888) 542-1011.









REQUIRED PARTS:

Part Name	MY	Model	Part Number		Figure
			2.4L GDI	2.0L T-GDI	
Engine Long Block	14-15	TF	21101 2GK06QQKR	N/A	
	14-16	SL	21101 2GK36QQKR	21101 2GK37QQKR	
	15	QF	21101 2GK06QQKR	21101 2GK08QQKR	
		XMa ULEV & SULEV	21101 2GK11QQKR	N/A	
	17-18	QL	21101 2GK35QQKR	21101 2GK39QQKR	
	16-17	UMa	21101 2GK31QQKR	21101 2GK32QQKR	
	18		21101 2GK33QQKR		
	16-18	JF, JFa	21101 2GK34QQKR	21101 2GK32QQKR	

Note: You may receive an engine with a part number ending in “QQK” when a part number ending in “QQKR” was ordered. Both part numbers are interchangeable and acceptable in the warranty claim.

Continued on page 16.

SUBJECT: ENGINE REPLACEMENT INSTRUCTIONS FOR DTC P1326 (PI1802Y/Z)

Models	Part Name	Engine	Part Number	Figure	
TF, SL, QF, XMa	Service Kit I	2.4L GDI	21111 2GK50QQK		
		2.0L T-GDI	21111 2GK60QQK		
UMa, QL, JF, JFa		2.4L GDI	21111 2GK51QQK		
		2.0L T-GDI	21111 2GK52QQK		
TF, SL, QF, XMa		Service Kit II	2.4L GDI and 2.0L T-GDI	21111 2GK70QQK	
UMa, QL, JF, JFa			2.4L GDI	21111 2GK71QQK	
			2.0L T-GDI	21111 2GK72QQK	
All		Drive Plate Bolts	2.4L GDI and 2.0L T-GDI	23311 25050	
	Oil Cooler Tube Assembly (replacement is conditional, refer to page 10)	2.4L GDI	25470 2G050QQK		
		2.0L T-GDI	25470 2G650QQK		
All	Knock Sensor	2.0L-T GDI	39250 2G700	N/A	
		2.4L GDI	39250 2G100		

***Oil Cooler Tube assembly replacement is conditional, refer to page 10.**

* NOTICE

VIN inquiry data for this repair is provided for tracking purposes only. Kia retailers should reference **PI1802Y/Z*** when accessing the KDealer+ system.



SUBJECT: ENGINE REPLACEMENT INSTRUCTIONS FOR DTC P1326 (PI1802Y/Z)

WARRANTY CLAIM INFORMATION FOR:

PI1802 Y1, PI1802 Z1 AND PI180S (DIAGNOSIS ONLY CLAIMS):

❗ IMPORTANT

REFER TO WARRANTY BULLETIN 2020-26 (PI1802Y, Z OR 180S) FOR MODEL-SPECIFIC LABOR OPERATIONS AND TIMES, AS WELL AS SPECIFIC CLAIM SUBMISSION PROCEDURES. **NOTE:** SEE APPENDIX 1 & 2 ON PAGE 19 AND 20 FOR ADDITIONAL TECHLINE PWA INFORMATION REQUIRED.

Flow Chart Symptom #A	Diagnostics	Repairs
PI1802<u>Y</u> DTC P1326 (No TL PWA Required)	BCT Pass	ECU Upgrade
		R& R Knock Sensor
	BCT No Pass	Engine R&R
		Engine R&R + ECU Software Update

Flow Chart Symptom #B	Diagnostics	Repairs
PI1802<u>Z</u> Engine Noise (TL PWA Required)	Check Oil + BCT Pass	Inspection + Noise Check (N) (PI180S Claim) Repairs under normal warranty coverage MAY apply. Separate TL PWA case required
		Noise Check + TL PWA + Engine R&R
		Noise Check + TL PWA + Engine R&R + ECU Software Update
	Check Oil + BCT No Pass	Engine R&R with TL PWA
Engine R&R with TL PWA + ECU Software Update		

Flow Chart Symptom #C	Diagnostics	Repairs
PI1802<u>Z</u> Engine No Crank (TL PWA Required)	Check Oil Amount + Check Crank Rotation (+ 94lb.ft)	Inspection Only (PI180S Claim) – Repairs under normal warranty coverage MAY apply – separate TL PWA case required)
	Check Oil Amount + Crank Rotation (- 94lb.ft) + BCT Pass	Diagnosis Only (PI180S Claim) – Repairs under normal warranty coverage MAY apply – separate TL PWA case required)
	Check Oil Amount + Crank Rotation (-94lb.ft) + BCT No Pass	Engine R&R with TL PWA
		Engine R&R + ECU Software Update with TL PWA
	Check Oil Amount + Crank Rotation (+94lb.ft) (No BCT)	Engine R&R with TL PWA
Engine R&R + ECU Software Update with TL PWA		

Note: Photo requirement for Warranty Claim submission as outlined in TSB PI1802: Separate photos of the oil dipstick reading, oil filler cap, oil filter opening must be attached to the claim using Warranty Claim Attachment type 'XX - Other'. Failure to provide the required photos may result in claim rejection or chargeback. Refer to [Warranty Bulletin 2020-26](#) for details regarding coolant and substitute transportation reimbursement requirements.



SUBJECT: ENGINE REPLACEMENT INSTRUCTIONS FOR DTC P1326 (PI1802Y/Z)

Appendix 1 (Techline Prior Work Authorization)

Inspection Type	Findings	Action
Oil Dipstick Oil Filler Cap Oil Filler Opening	Suspect Exceptional Neglect (NG) <ul style="list-style-type: none"> Physical inspection of engine shows oil sludge/buildup/varnish. 	<ol style="list-style-type: none"> Perform Oil Level Measurement Dealers are to empty crankcase oil into a measuring container and record findings. Note: Take a photo of the oil level using KDS. Request Maintenance Records: <u>Customers may be required to provide Maintenance Records in the absence of sufficient CP/Carfax data.</u> Customers have 5 business days to respond to dealer's request for maintenance records (or to confirm that they are gathering records and/or need additional time), in which case customers will be permitted an additional 5 business days (10 days total) to produce records <u>or</u> confirm they do not have records to provide.
	Oil level & Oil condition (OK)	KSDS Installed <u>or</u> DTC P1326 Stored? Applicable Flowchart A, B or C.

Note: Customers who perform their own maintenance may provide a service record log along with receipts for the purchase of oil filter and engine oil.

Maintenance Record Request	Maintenance Record Results	Action
Kia is required to verify Oil change records from dealers, Carfax (or similar reputable 3rd. parties) but may also request maintenance records from the customer.	<ul style="list-style-type: none"> One oil change gap of greater than 14 months and/or 10,500 miles. Previous diagnosis of excessive oil consumption issues but the customer did not obtain a repair to address such issues within 30 days or 1,000 miles (whichever comes first), subsequent after a completed oil consumption testing and confirmed diagnosis. No "Exceptional Neglect" can apply to otherwise eligible engine failures that occur within a Class Vehicle's first 15,000 miles. 	<p>Exceptional Neglect Determined.</p> <p>Any repairs performed are the customer's responsibility or insurable extended warranty plan.</p> <p>Diagnosis Coverage Only.</p>
	Maintenance Records Provided	Repair Assistance (RA)



Appendix 2 Techline Prior Work Authorization (PWA)

Scenario	Description	Action Required
Flowchart A	DTC P1326 Stored	No TL PWA required.
Flowchart B	Engine Noise	<p>TL PWA required for all dealers – Video of condition Video requirement examples below are for illustration purposes, individual requirements will vary based upon the condition reported:</p> <ul style="list-style-type: none"> Video should be continuous and show the VIN (most convenient VIN plate) and pan to show the engine condition. For engine seizures, attempt to turn over engine with torque wrench in video and exceeding 94 lb.ft. For hole in engine block, show hole in video For severe engine noise demonstrate severity of the noise without over accelerating (to RPM redline) the engine in video (Refer to Appendix 3)
Flowchart C	Engine Seized Bearing Clearance Test <u>or</u> No Test	

Note: Additional information may be requested by the Techline agent, including but not limited to screenshot of the stored DTC(s), ROM ID and Bearing Clearance Test (BCT) results.

NOTICE

VIN inquiry data for this repair is provided for tracking purposes only. Kia retailers should reference PI1802* when accessing the KDealer+ system.



SUBJECT: ENGINE REPLACEMENT INSTRUCTIONS FOR DTC P1326 (PI1802Y/Z)

Video Instructions for Seized Engine Inspection: (Flowchart C)

Prepare the vehicle prior to the video by removing the spark plugs and drive belt as well as setting the torque wrench to 94 lb.ft.

1. Start video showing the vehicle being worked on and move the camera in towards the dash VIN tag.



Note: Continue filming video until step 7.

2. Show the removed spark plugs.



3. Show the empty spark plug holes from the engine.



5. Show the removed drive belt and attached torque wrench to crank bolt.



6. Show the engine being cranked and torque specification exceeding 94 lb.ft. torque.



7. Submit video with Techline PWA case.



Appendix 3 (Video Capture & Upload)

Note: Additional information required to open a Techline case including but not limited to screenshot of the stored DTC(s), ROM ID and Bearing Clearance Test (BCT) results.

The Chrome™  browser should be used to access the Techline portal. Follow the steps below to clear the default browser if it is other than Chrome™.

For KDS Tab 10.1 Tablets:

1. Select “Settings” from the App Screen.
2. Select the “General” tab at the top.
3. Select “Default Applications”.
4. If “Internet” is the default browser, select the CLEAR button.
If “Chrome” is the default browser, further action is not required.

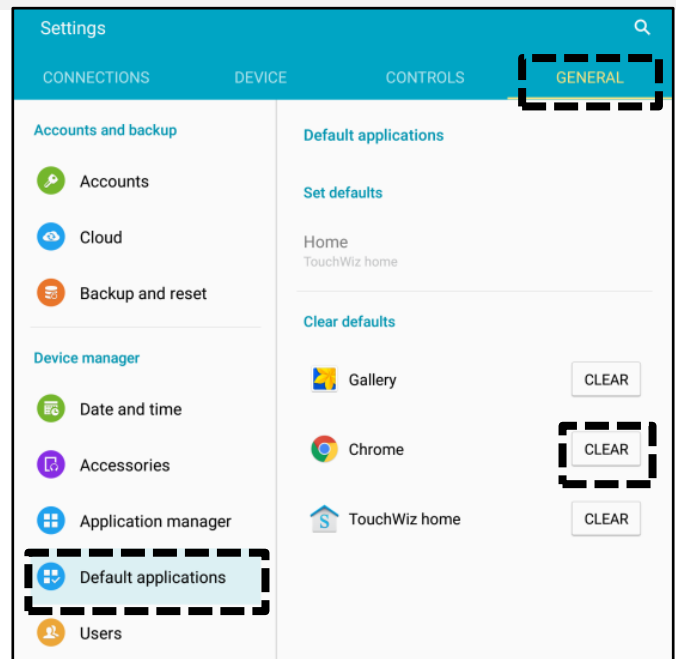

5. When opening the Techline portal, select “Chrome” and select Always”.

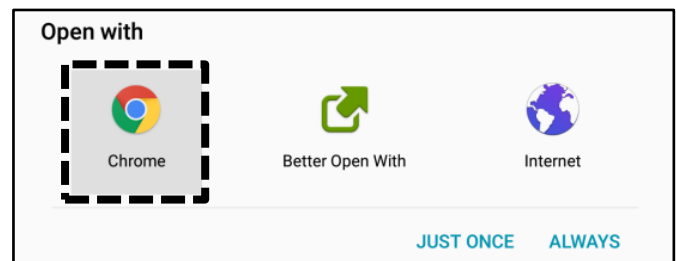

SUBJECT: ENGINE REPLACEMENT INSTRUCTIONS FOR DTC P1326 (PI1802Y/Z)
For KDS Tab S2 Tablets:

1. Select "Settings" from the App Screen.
2. Select "Applications".
3. Select "Default Applications".

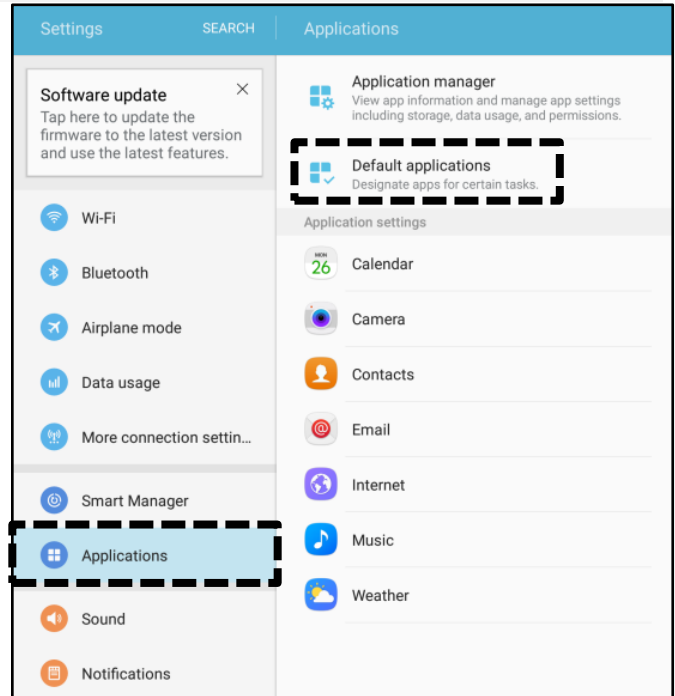

4. Select "Browser app".

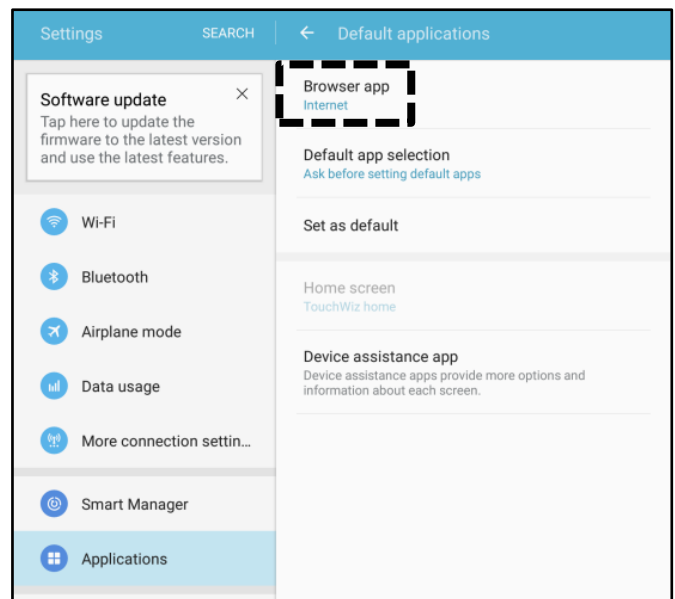

5. Ensure "Chrome" is selected.

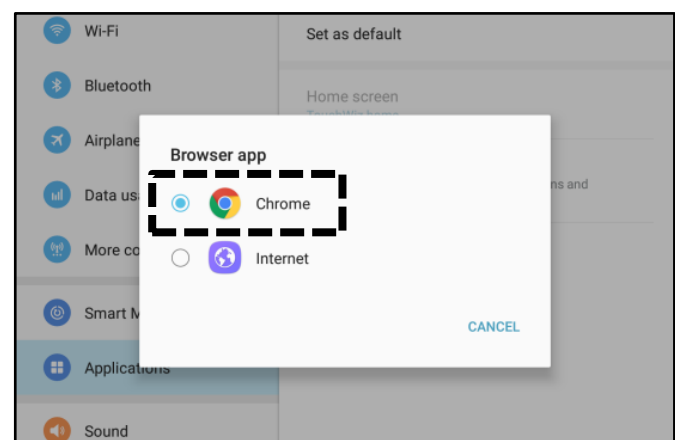

Attaching Video to a Techline Case:

1. Open K-Support in the device Chrome™ browser or select the “Techline” button on KDS home page.

<https://ksupport.kiausa.com>

2. Open your existing Techline case for the vehicle requiring a video capture by selecting the case number.

3. Select “Attachment”.

4. Select “Add Files”.

5. Select “Camcorder” and the video camera will open.

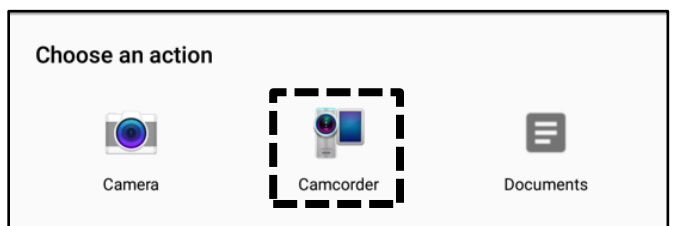
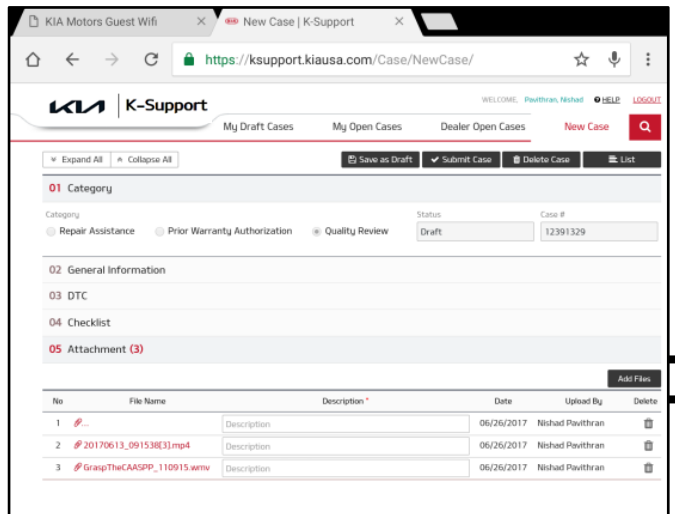
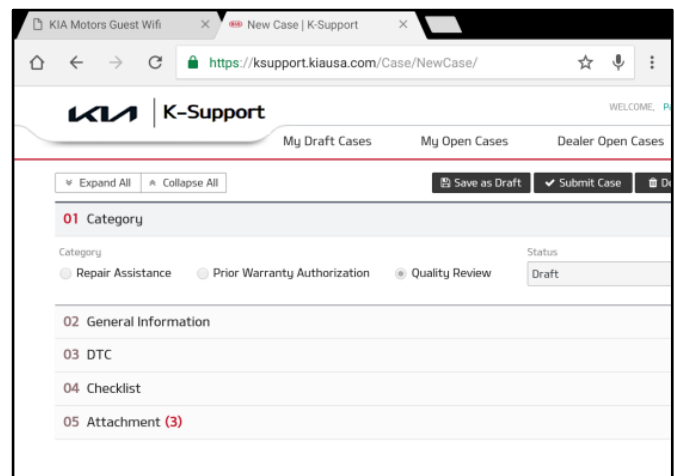
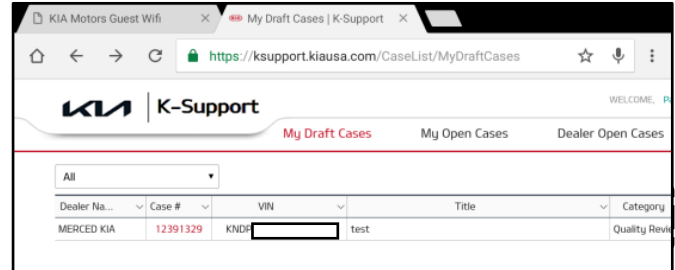

SUBJECT: ENGINE REPLACEMENT INSTRUCTIONS FOR DTC P1326 (PI1802Y/Z)

6. Start by recording the VIN. Ensure sun glare is not reflecting off windows or other objects.

Without stopping the recording, capture the area of the vehicle displaying the issue. i.e.;

- Engine Noise – record the engine.
- Hole In Block – record the side of the engine with the damage.
- Seized Engine – record a technician trying to turn the engine over with a torque wrench.



★ NOTICE

NOTE: Ensure the video size is set to “Limit to email”. Only record the VIN and the engine exhibiting the concern. Any additional information will increase the size of the video and make it difficult to upload or download.

7. Stop the video when you captured what is needed. Select “OK” to use this capture or “RETRY” to capture the video again.
8. Ensure a description of the recording. For example, engine knock or smoke from exhaust.
9. Select “Submit Case”.

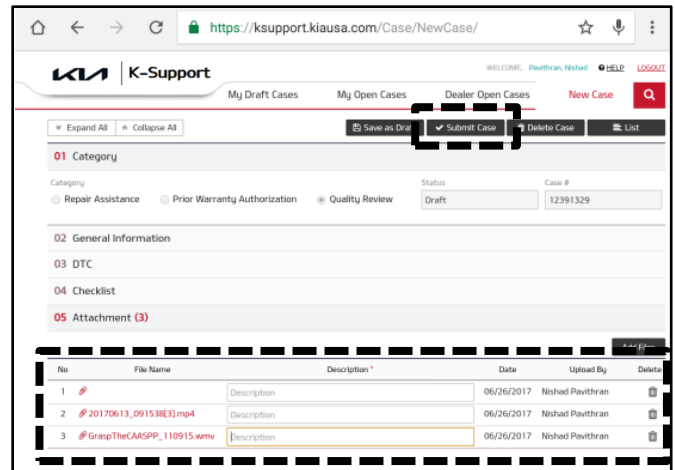

10. Select “Yes” when the confirmation message below appears.

Note: Selecting anything other than “Yes” will not save the video capture.

