



# Service Bulletin

Bulletin No.: 19-NA-206

Date: March, 2024

## TECHNICAL

**Subject: Intermittent Shift to Park Message Displayed While Vehicle in Park, DTC B000A Set**

Brand:	Model:	Model Year:		Date Breakpoint:		Engine:	Transmission:
		from	to	from	to		
Chevrolet	Blazer	2019	2019	SOP	Prior to April 2, 2019	All	All
	Malibu	2016					
	Traverse	2018					
	Volt	2016					
GMC	Acadia	2017					
Holden	Acadia	2019	2020				

<b>Involved Region or Country</b>	North America, Russia, Middle East, Israel, Palestine, Chile, Colombia, Peru, GM Korea Company, Australia/New Zealand, Other Africa
<b>Condition</b>	Some customers may comment on seeing an intermittent Shift to Park message when the vehicle has been shifted into Park, and the ignition has been turned to the Off position. Aside from seeing the message, technicians may find DTC B000A set.
<b>Cause</b>	The cause of the condition may be that the park switch in the transmission control (shifter) assembly is not pulling the BCM signal low to electronically show that the vehicle is in the Park position.
<b>Correction</b>	Verify the condition and follow the steps in the Service Procedure below. R & R the transmission control, install a new shifter harness, then upon reinstalling the transmission control, install an In-line Shifter Wire Harness Jumper between the shifter base connector and the console harness connector.

**Important:** Service agents must comply with all International, Federal, State, Provincial, and/or Local laws applicable to the activities it performs under this bulletin, including but not limited to handling, deploying, preparing, classifying, packaging, marking, labeling, and shipping dangerous goods. In the event of a conflict between the procedures set forth in this bulletin and the laws that apply to your dealership, you must follow those applicable laws.

**Service Procedure**

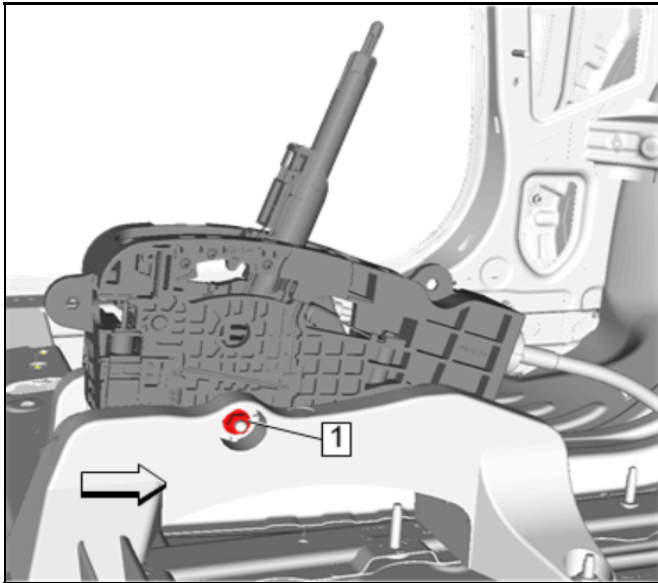

4489334

1. Remove the transmission control from the vehicle. Refer to *Transmission Control Replacement* in SI.
2. Remove the transmission control base plate, as necessary, and place the transmission control on a suitable work surface.

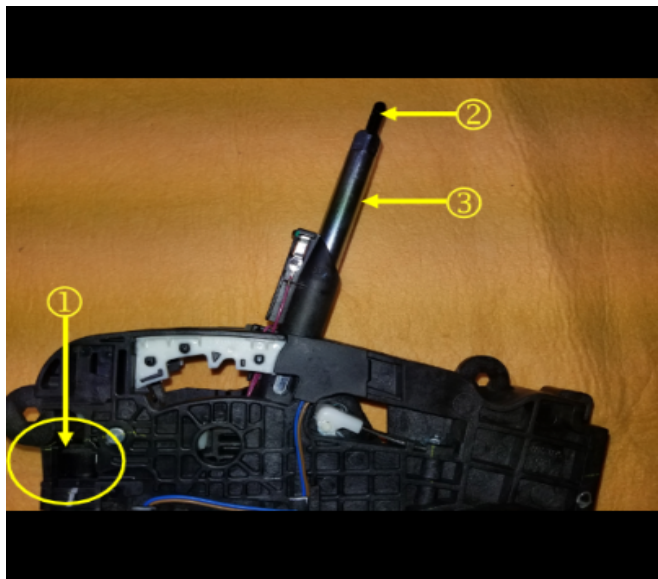

5682904

3. Move the shift rod out of Park position:
  - 3.1. From the back side of the shifter, use a finger to depress the Brake Transmission Shift Interlock (BTSI) solenoid (1) and release the lock arm.
  - 3.2. Depress the shift button (2) on top of the shifter.
  - 3.3. Move the shift rod (3) forward out of Park, to allow access to Park Switch pins.

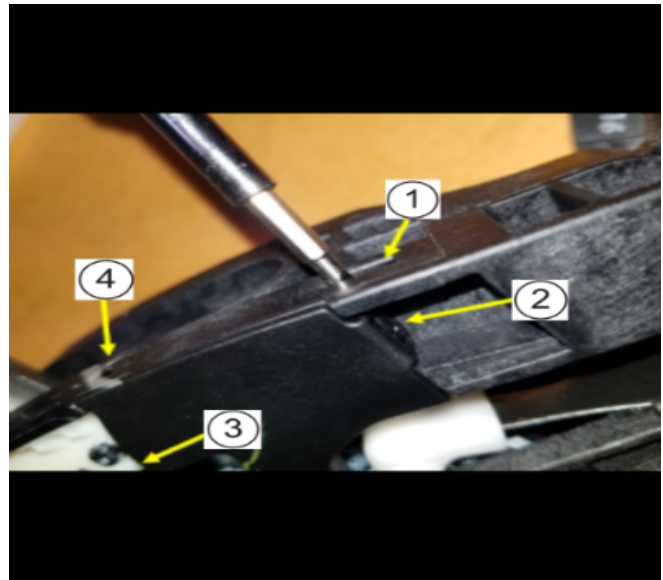

5845790

4. Remove the Park Switch Cover:

**Note:** The slot (1) on top of the shift control allows easier access to the tab.

- 4.1. Use a pick, or screwdriver, to lift and release the rear most tab (2) of cover.
- 4.2. Release the lower front tab (3) next.
- 4.3. Release the top tab (4) last and remove the cover.



5682906

- 5. Using a pick or screwdriver, push the Park Switch pins (1) out of the shift control body, and release the Park Switch.



5682907

- 6. Using a pick or screwdriver, release and lift the Park Switch (1) out of the shift control body.



5682908

- 7. Use needle nose pliers to release the BTSI lock.



5682909

- 8. Using a pick or screwdriver, lift the BTSI solenoid (1) out of pocket in shift control.



5682910

**Note:** There are two styles of Tap Up, Tap Down connectors. One is nested (shown above), one is loose.

9. Using a pick or screwdriver, disconnect the Tap Up, Tap Down harness in the shift control assembly.

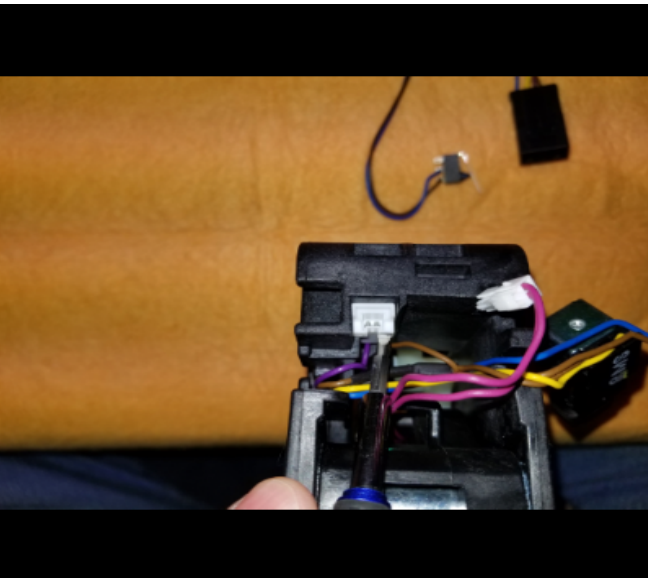

5682911

10. Using a pick or screwdriver, lift the Tap Up, Tap Down harness from the nest in the shift control assembly.

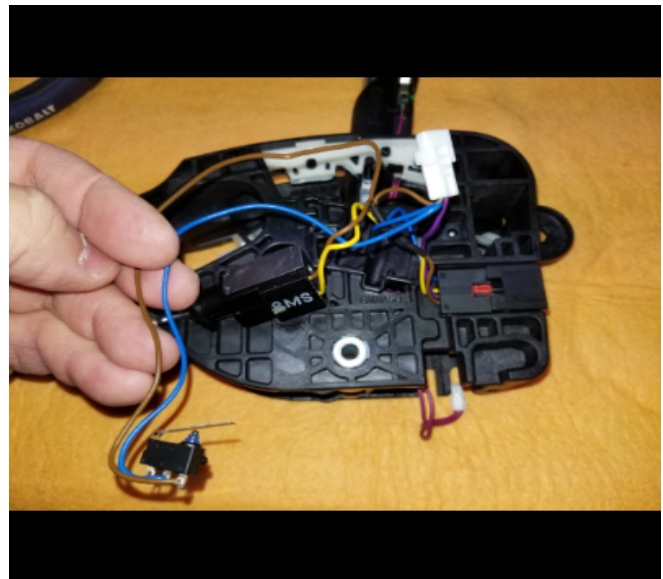

5682912

11. Carefully lift all wiring from the shift control assembly.



5682913

12. Carefully insert a pick or screwdriver between the shift control wire harness connector and shift control body, to release lock tab and lift up on connector and release.



5682916

13. The wire harness is now free from the shift control.



5682918

14. Start installation of the new shift control wiring harness:
- 14.1. Begin by inserting shift control harness connector into the shift control assembly.
  - 14.2. Fit the wire harness below the retainer tab in the shift control assembly.

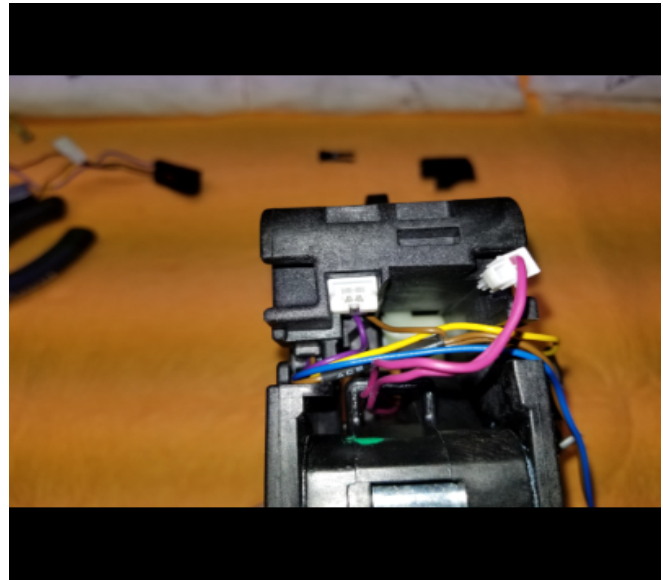

5682920

15. Push the Tap Up, Tap Down harness connector in the nest in the shift control assembly, and insert the Tap Up, Tap Down shift control harness connector.



5682922

16. Lay the BTSI solenoid and Park Switch on the shift control assembly, in the approximate location of installation.

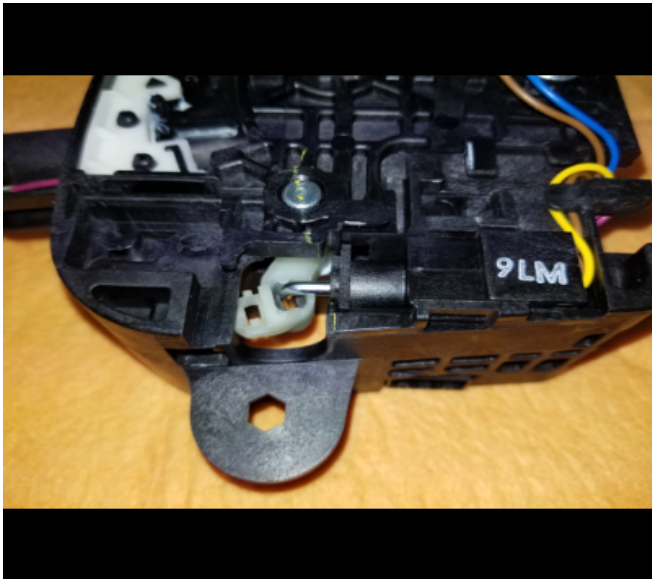

5682925

**Note:** When installing, be sure to align the BTSI elbow connection so it fits in the BTSI lock release.

17. Install the BTSI solenoid in the slots with the coil side down.



5682928

18. Push the BTSI solenoid lock in place until it clicks.



5682930

19. Install the BTSI solenoid wiring and the Park Switch wiring:
- 19.1. Press the wiring for the BTSI solenoid and the Park Switch under the tabs on the body of the shift control assembly.
  - 19.2. Press the Park Switch into place with the two alignment pins.
  - 19.3. Put the shift control in the Park position.
20. Check the operation of the Park Switch:

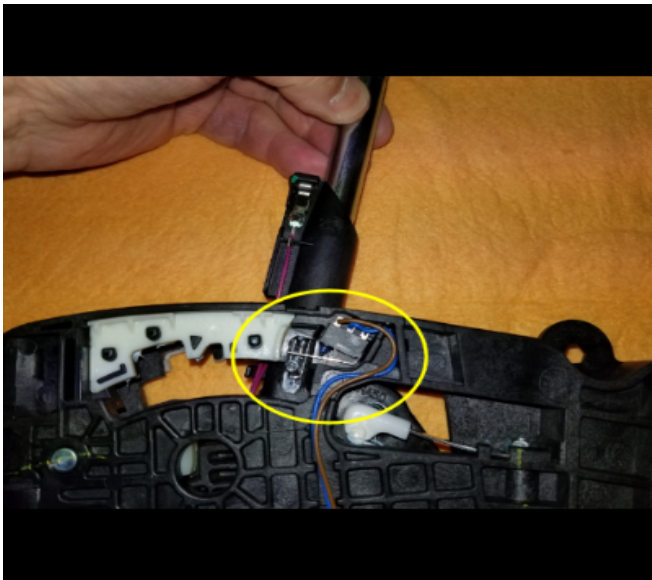

5682931

- 20.1. Press the shift shaft release rod on the top of the shift control to open the Park Switch to verify it opens all the way and stays in place.



5682933

- 20.2. Release the rod and cycle a few times to ensure the Park Switch is fully seated and opening and closing properly.
21. Carefully install the Park Switch cover, being sure all three tabs lock in place.

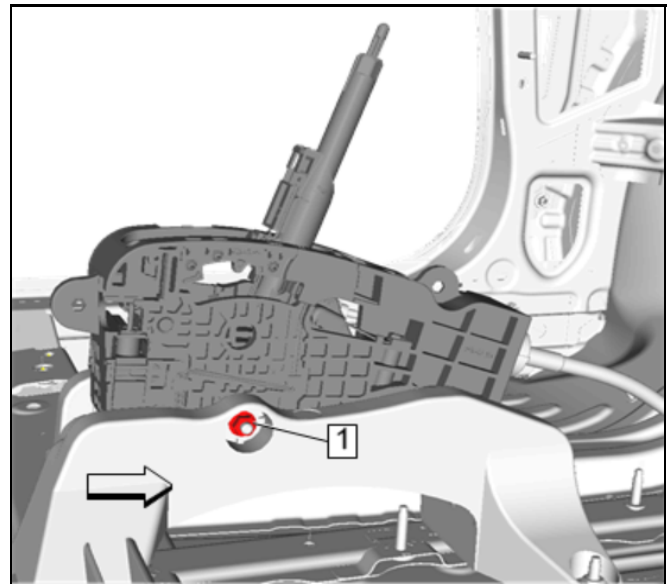

4489334

22. Reinstall the transmission control assembly in the vehicle. Refer to *Transmission Control Replacement* in SI.

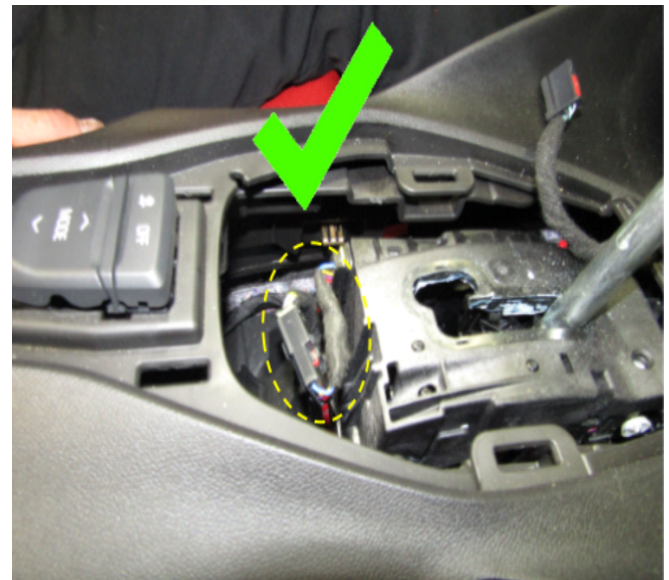

5404694

**Caution:** Ensure the jumper harness is not twisted or kinked.

23. Install the Jumper harness (P/N 84733196) between the shift control and the console body harness connector.
24. Start the vehicle and verify that the Shift to Park message is NOT displayed.

## Parts Information

Causal Part	Description	Part Number	Qty
N/A	HARNESS ASM-A/TRNS CONT WRG (Jumper)	84733196	1
	SWITCH ASM-A/TRNS CONT - (2016-2018 Malibu/Acadia/Traverse)	84955381	1
	SWITCH ASM-A/TRNS CONT - (2016-2019 Volt)	84955382	
	SWITCH ASM-A/TRNS CONT - (2019 Acadia, Blazer, Traverse, Malibu, Holden Acadia)	84955379	
	COVER-A/TRNS CONT TR	84955380	1, if necessary <b>Note:</b> Cover is NOT needed if step #4 is completed properly. Only order if damaged.

## Warranty Information

**Note:** Specific to the Volt model, repairs are covered under the **Voltec (Electric and Hybrid Vehicle) Warranty**.

For vehicles repaired under the Bumper-to-Bumper coverage (Canada Base Warranty coverage), use the following labor operation. Reference the Applicable Warranties section of Investigate Vehicle History (IVH) for coverage information.

Labor Operation	Description	Labor Time
5480908*	Remove and Reinstall Transmission Control, Install New Shifter Harness, Add Wire Harness Jumper	Blazer - 0.8 hr
		Malibu - 0.8 hr
		Traverse - 0.7 hr
		Volt - 1.1 hrs
		GMC Acadia - 1.4 hrs
		Holden Acadia - 1.4 hrs
*This is a unique Labor Operation for bulletin use only.		



<b>Version</b>	10
<b>Modified</b>	<p>Released September 11, 2019</p> <p>Revised September 19, 2019 – Removed the Camaro model.</p> <p>Revised October 14, 2019 – Updated the Warranty Information to add a Note for the Voltec Warranty.</p> <p>Revised January 30, 2020 – Added a reference to DTC B000A in the Condition and added repair information to steps #4 and 8 of the Service Procedure.</p> <p>Revised October 30, 2020 – Updated the Warranty Information with Add Times for Transmission Control Replacement.</p> <p>Revised December 11, 2020 – Updated the Correction section, changed the complete Service Procedure, Parts Information and Warranty Information.</p> <p>Revised February 05, 2021 – Removed the 2016 Volt Model and added a Note to the Cover listed at the bottom of the Parts Information table.</p> <p>Revised May 19, 2021 – Added the 2016 Volt model.</p> <p>Revised June 07, 2021 – Added Part Description to Harness Assembly and Corrected Graphic Callouts above Step 4.</p> <p>Revised March 13, 2024 – Added 2020 Holden Acadia and the Important statement.</p>

