



Preliminary Information

PIT5689F No Restart after an Auto Stop Event / No Crank / Dead Battery / Glow Plug / Transfer Case / SES MIL / DTC

Product Investigation Review Required

Models

Brand:	Model:	Model Years:	VIN:		Engine:	Transmissions:
			from	to		
Chevrolet	Silverado 1500 (New Model)	2019	All	All	All	All
Chevrolet	Silverado 1500	2020 - 2024	All	All	All	All
Chevrolet	Silverado 2500/3500 HD	2020 - 2024	All	All	All	All
GMC	Sierra 1500 (New Model)	2019	All	All	All	All
GMC	Sierra 1500	2020 - 2024	All	All	All	All
GMC	Sierra 2500/3500 HD	2020 - 2024	All	All	All	All

Involved Region or Country	North America
Condition	<p>Some customers may comment of the following:</p> <ul style="list-style-type: none"> - After an auto-stop event the engine does not restart (if equipped). - No crank (may be intermittent) - Dead Battery - Transfer Case Range Actuator Learn Failed - SES MIL with any of the following DTCs: P0562, P0617, P0621 P0622, P0700, P1005, P26E6, P305D, P305E, P2796, U010E, U0102, U0106, U0284, U0285, U0672, U029D, U029E, U02A1, U02A3, U0623, U111A, U111E, U1348, U18DE, P066B, P066D, P066F, P067B, P067D, P068D, P068F, C15AC, P0671, P0672, P0673, P0674, P0675, P0676 P067F, P0677, and P0678
Cause	These concerns could be caused by a broken or loose engine ground cable/strap, which grounds the engine (2) to the body (1), as shown below.

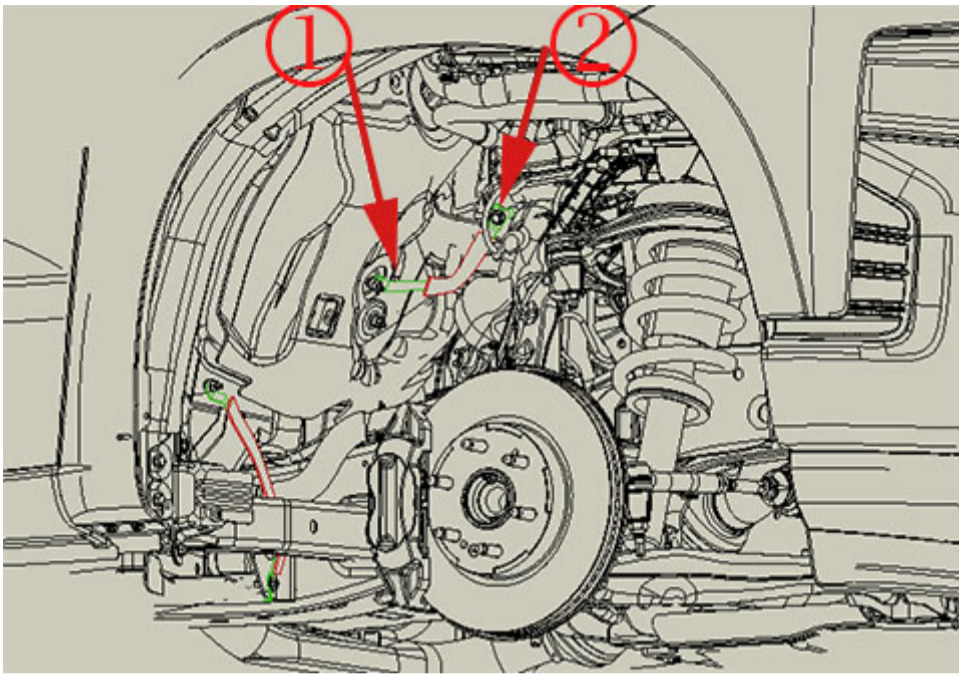

1 - G132
2 - G134



Shown above is ground G132 loose.

Correction:

Inspect the engine to body ground cable/strap, G132 and G134. Tighten any loose ground connections or replace any damaged ground cable/strap. Ensure that the ground cable/strap is properly orientated to prevent damage to the ground cable/strap caused by powertrain movement.

Warranty Information

For vehicles repaired under the Bumper-to-Bumper coverage (Canada Base Warranty coverage), use the following labor operation. Reference the Applicable Warranties section of Investigate Vehicle History (IVH) for coverage information.

Labor Operation	Description	Labor Time
4042010	Battery Negative Cable Extension Cable Strap Replacement	Use Published Time

Version History

Version	7
Modified	<p>06/04/2019 - Created on</p> <p>11/22/2019 - Update the title, condition and correction.</p> <p>06/22/2020 - Updated to temporarily refer to PIE0572 for this condition.</p> <p>02/19/2021 - Updated to Title, Condition, Cause and Correction.</p> <p>06/10/2021 - Updates to the Warranty Section</p> <p>01/30/2022 - Update to model list</p> <p>02/22/2024 - Updates to the Title, Models, and Condition sections</p>



© 2024 General Motors. All Rights Reserved.