

Title: External Sound Module Location

Applicability: All Revero GT and GTS and GS-6 (Karma “2.0 vehicles”)

PURPOSE:

This is an update to the Karma GT and GTS and GS-6 Workshop Manual (“Workshop Manual”). All the 2.0 vehicle models, as mentioned in “Applicability” above, are built with an External Sound Module (“ESM”) located behind the front fascia. To promote the best possible customer experience, diagnostics of and replacement the ESM should reference this document for location and any removal steps. The correct procedure is found in the section for SPEAKER – FRONT EXTERNAL, in the work shop manual. This bulletin is to provide further clarity

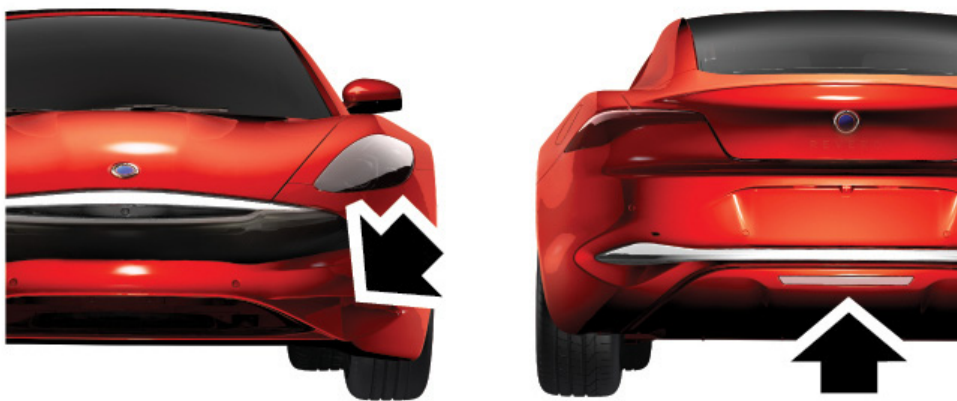

Fig. 1

The ESM module is also the front speaker, the rear speaker appears similar but does not contain the control module. These are two components of the same external sound system. The speaker locations are behind the fascias as indicated (Fig. 1). The ESM is shown below (Fig. 2)

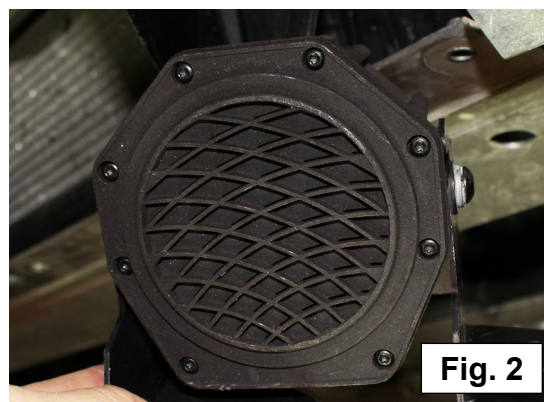

Fig. 2

Karma Automotive bulletins and service documents are intended for use by experienced and trained Technicians. If you lack the skills, tools, equipment and a suitable workshop for any procedure described in this document, we suggest you leave such repairs to a Karma retailer and service provider. See your service provider for advice on whether your vehicle may benefit from the information contained within this document. The information contained in the Karma Bulletin is accurate at the date of publication. However, Karma Automotive regularly updates technical information. Please check with your Karma Automotive Retailer and Karma Automotive service provider that the bulletin you intend to use contains the latest available information.

Title: External Sound Module Location

Applicability: All Revero GT and GTS and GS-6 (Karma "2.0 vehicles")

1. Open the hood and locate the connector for the External Sound Module (ESM) near the washer bottle, as shown in Fig 3.

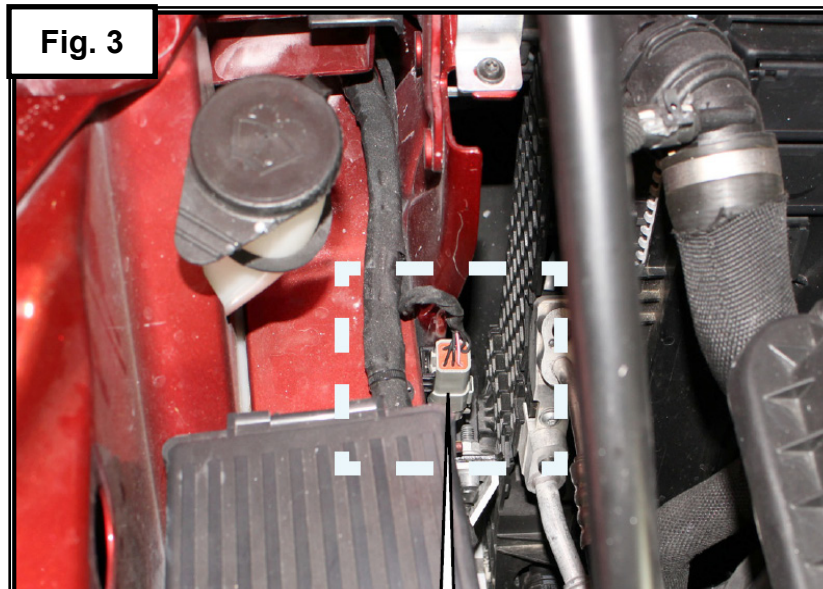

- 2 . Carefully disconnect the ESM connector (Fig. 4).

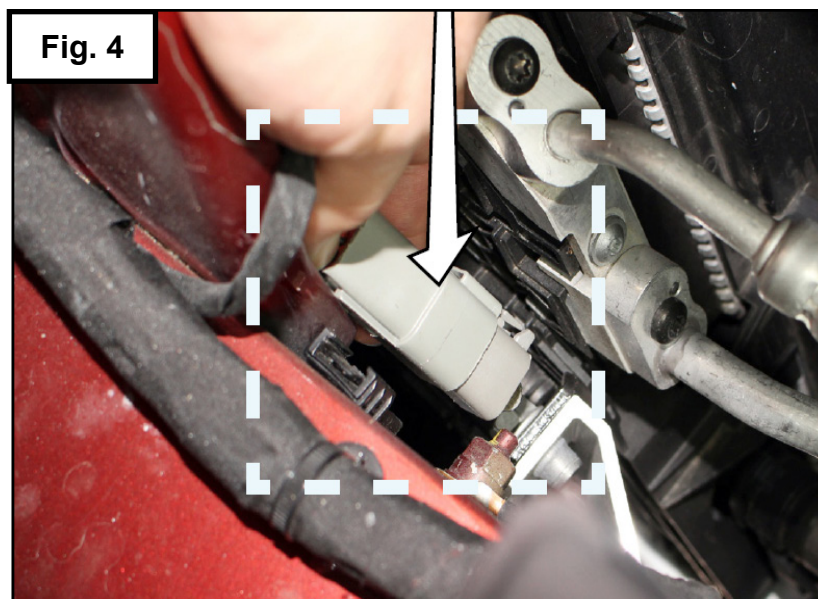

Karma Automotive bulletins and service documents are intended for use by experienced and trained Technicians. If you lack the skills, tools, equipment and a suitable workshop for any procedure described in this document, we suggest you leave such repairs to a Karma retailer and service provider. See your service provider for advice on whether your vehicle may benefit from the information contained within this document. The information contained in the Karma Bulletin is accurate at the date of publication. However, Karma Automotive regularly updates technical information. Please check with your Karma Automotive Retailer and Karma Automotive service provider that the bulletin you intend to use contains the latest available information.

Title: External Sound Module Location

Applicability: All Revero GT and GTS and GS-6 (Karma “2.0 vehicles”)

3. Remove the lower valance from the front fascia (Fig. 5) – underside view of vehicle.

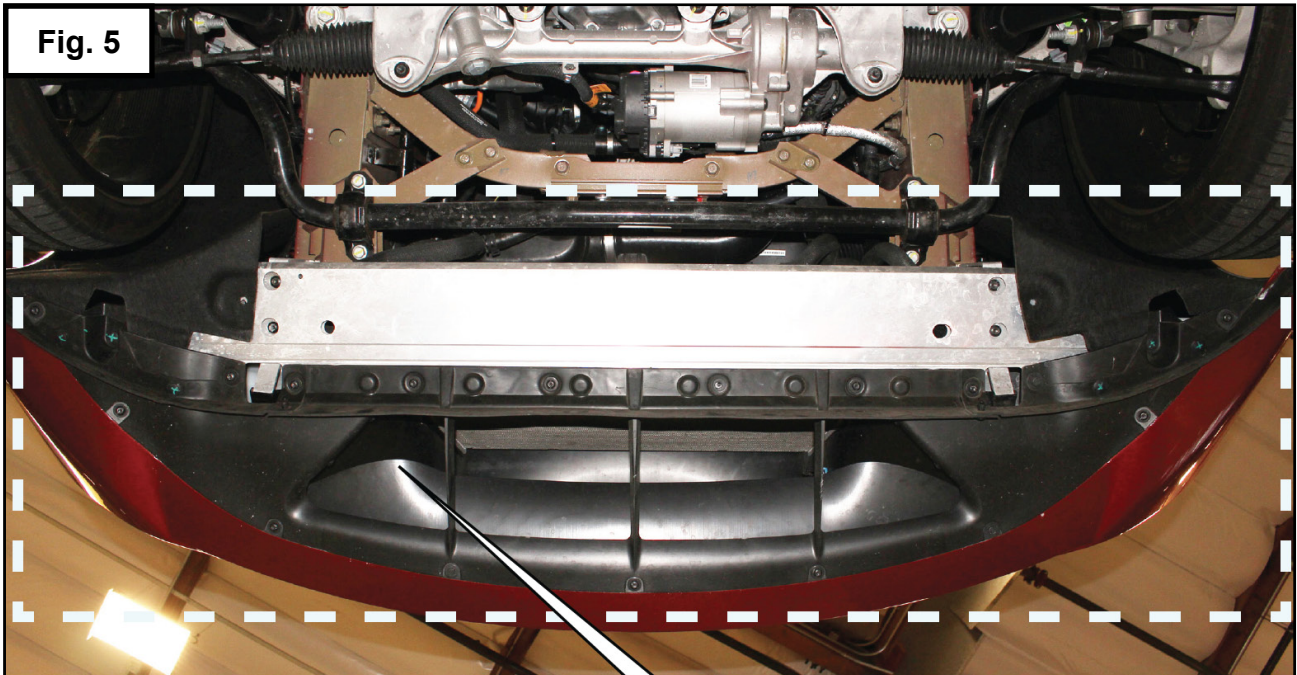

4. Locate the ESM on the left side of the front fascia, as shown in Fig 6.

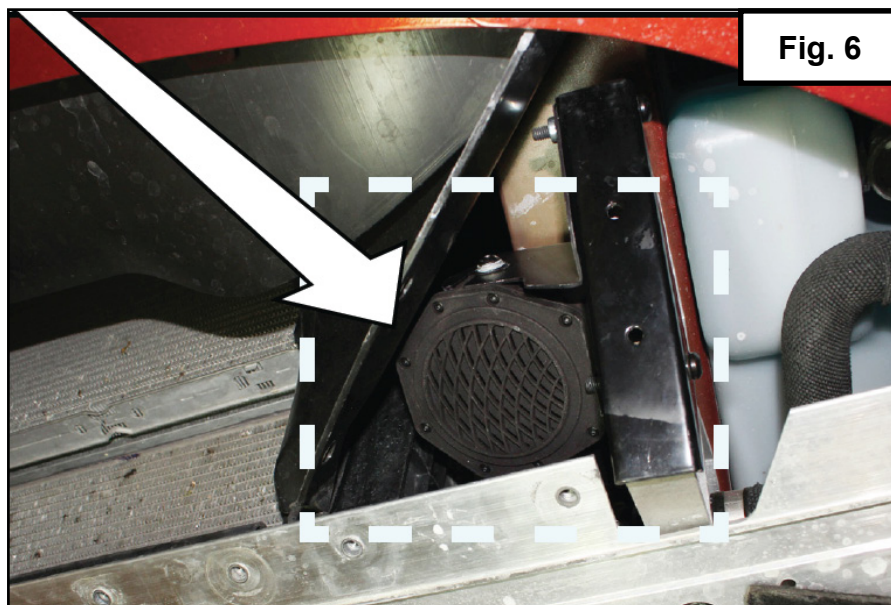

Karma Automotive bulletins and service documents are intended for use by experienced and trained Technicians. If you lack the skills, tools, equipment and a suitable workshop for any procedure described in this document, we suggest you leave such repairs to a Karma retailer and service provider. See your service provider for advice on whether your vehicle may benefit from the information contained within this document. The information contained in the Karma Bulletin is accurate at the date of publication. However, Karma Automotive regularly updates technical information. Please check with your Karma Automotive Retailer and Karma Automotive service provider that the bulletin you intend to use contains the latest available information.

Title: External Sound Module Location

Applicability: All Revero GT and GTS and GS-6 (Karma "2.0 vehicles")

5. Remove two (2) Torx head bolts from ESM bracket (1) - torque value 6.0Nm +/- 1 Nm, as shown in (Fig 7) front wheel well liners. There are 12 push pins on each liner.

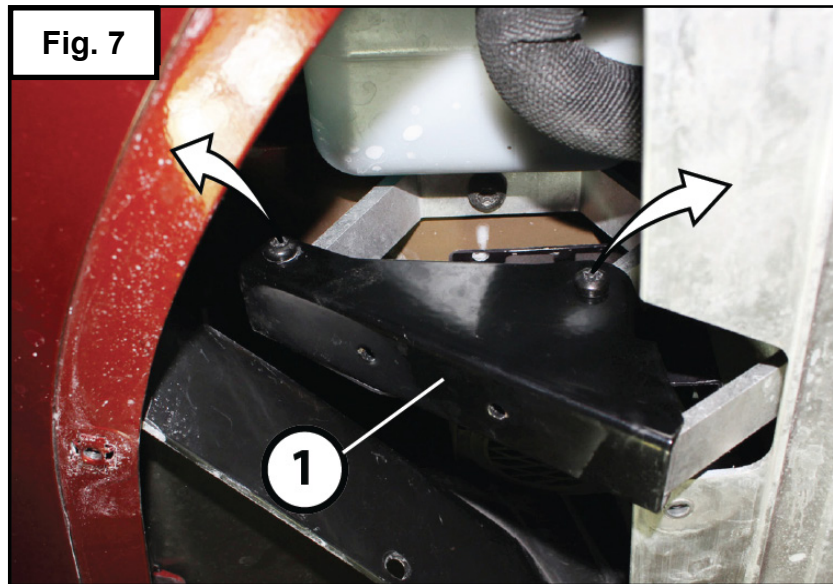

6. Remove the ESM from the front supports, as shown in (Fig. 8).

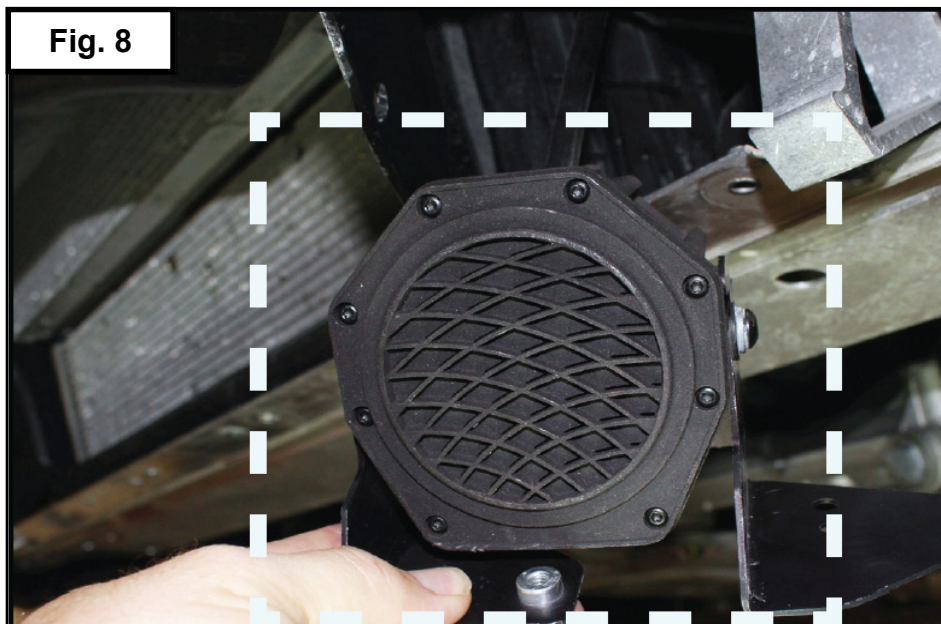

7. Installation of any replacement ESM is the reverse of the removal steps.

Karma Automotive bulletins and service documents are intended for use by experienced and trained Technicians. If you lack the skills, tools, equipment and a suitable workshop for any procedure described in this document, we suggest you leave such repairs to a Karma retailer and service provider. See your service provider for advice on whether your vehicle may benefit from the information contained within this document. The information contained in the Karma Bulletin is accurate at the date of publication. However, Karma Automotive regularly updates technical information. Please check with your Karma Automotive Retailer and Karma Automotive service provider that the bulletin you intend to use contains the latest available information.

Title: External Sound Module Parts Update

Applicability: All Revero GT and GTS and GS-6 (Karma "2.0 vehicles")

Reproduced here are the existing workshop manual instructions, including the rear module.

SPEAKER – FRONT EXTERNAL (External Sound Module) KRT No.: 90709005

REMOVAL

1. Raise and support vehicle. Refer to "LIFTING INSTRUCTIONS".
2. Remove front bumper lower closeout panel. Refer to "CLOSING PANEL - FRONT BUMPER".

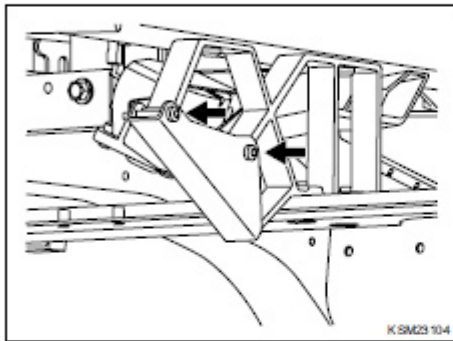

3. Remove (x2) bolts securing external speaker bracket from frame.

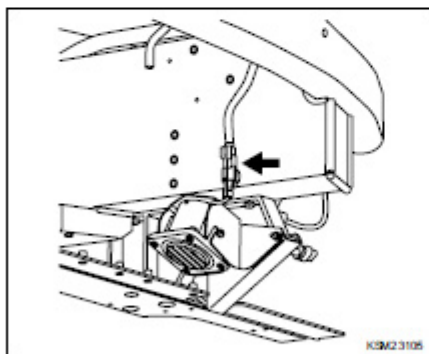

4. Lower external speaker and mounting bracket then disconnect harness connector.

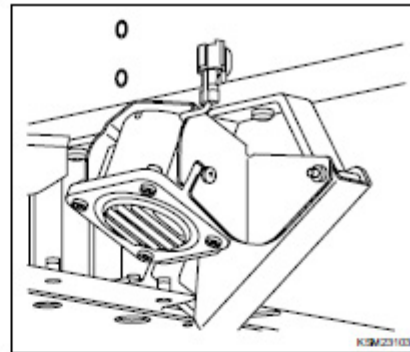

5. Loosen (x2) external speaker mounting bolts.

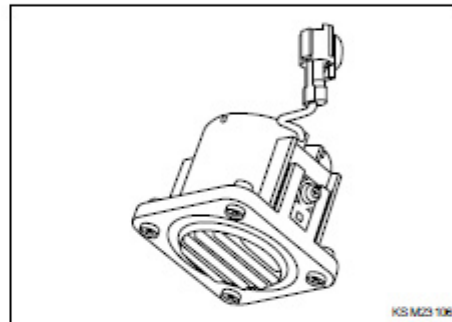

6. Remove external speaker from bracket.

INSTALLATION

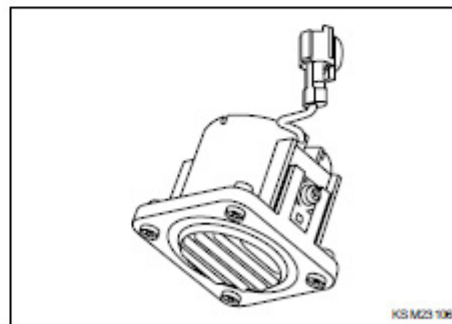

1. Install external speaker to bracket.

Title: External Sound Module Parts Update

Applicability: All Revero GT and GTS and GS-6 (Karma "2.0 vehicles")

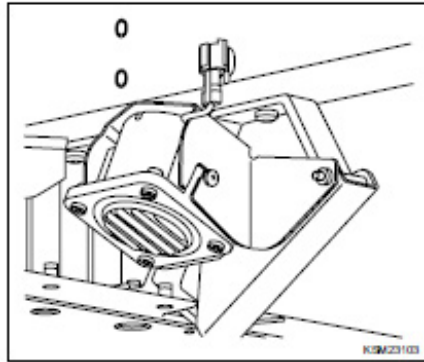

2. Tighten (x2) bolts securing external speaker to bracket. **Torque - 6 Nm**

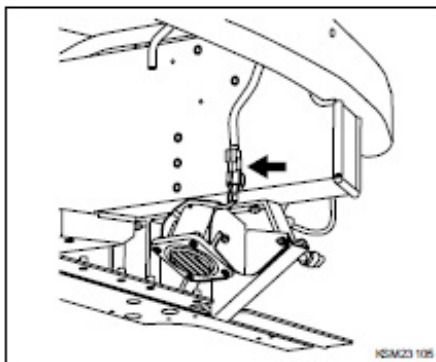

3. Raise up external speaker and mounting bracket then connect harness connector.

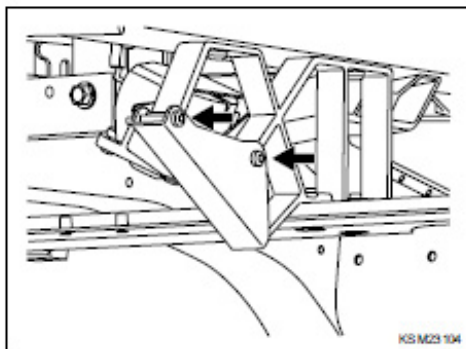

4. Install external speaker bracket to frame and install (x2) bolts securing bracket to frame. **Torque - 10 Nm**

5. Install front bumper lower closeout panel. Refer to "CLOSING PANEL - FRONT BUMPER".

6. Lower vehicle.

Title: External Sound Module Parts Update

Applicability: All Revero GT and GTS and GS-6 (Karma "2.0 vehicles")

SPEAKER – REAR EXTERNAL KRT No.: 90700900

REMOVAL

1. Raise and support vehicle. Refer to "LIFTING INSTRUCTIONS".

 **WARNING:** Make sure the vehicle is correctly supported before commencing work.

 **WARNING:** To avoid serious injury, use appropriate equipment to carry out this operation.

2. Remove diffuser. Refer to "DIFFUSER PANEL – REAR BUMPER".

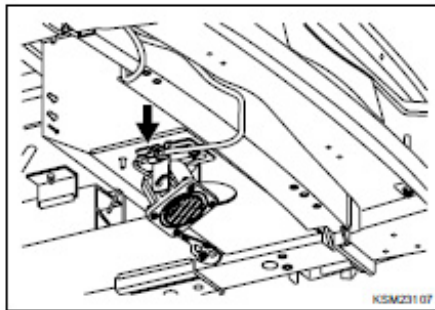

3. Disconnect speaker harness connector.

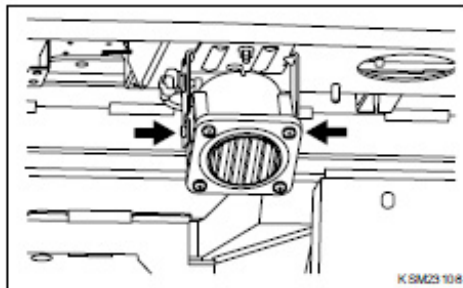

4. Loosen (x2) bolts securing rear external speaker from bracket.

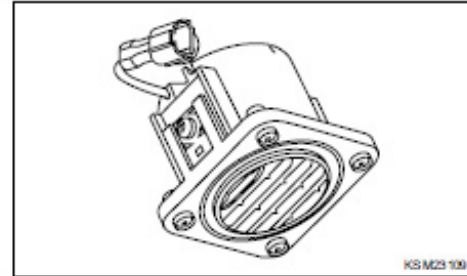

5. Remove rear external speaker from bracket.

INSTALLATION

IMPORTANT: Clean component mating surfaces, prior to installation.

1. Install rear external speaker to bracket.

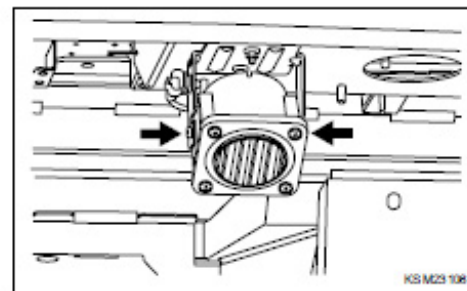

2. Tighten (x2) bolts securing rear external speaker to bracket. **Torque – 6 Nm**

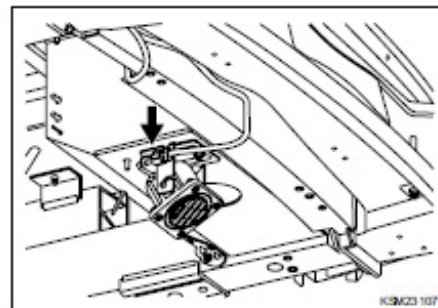

3. Connect speaker harness connector.
4. Install diffuser panel. Refer to "DIFFUSER PANEL – REAR BUMPER".
5. Lower vehicle.

Type: Service Communication

Year: 2024

Title: External Sound Module Location

System: Electrical (90)

Applicability: All Revero GT and GTS and GS-6 (Karma "2.0 vehicles")

Sequence: 01

First Release Rev: 0.1

PARTS REQUIRED:

PART NUMBER	DESCRIPTION	QUANTITY
C131181900301	External Sound Module (ESM)	1

SHOP SUPPLIES if Required:

PART NUMBER	DESCRIPTION	QUANTITY
N/A		

SPECIAL TOOLS:

DESCRIPTION
N/A

CAUSAL PART:

PART NUMBER	DESCRIPTION
C131181900300	External Sound Module (ESM)

LABOR CODES:

CODE	DESCRIPTION	TIME	DEFECT CODE
90-70-10-00	ESM R & R	0.7	90-70-10-33

SUBLET:

CODE	DESCRIPTION	AMOUNT
N/A		

WARRANTY DISPOSITION: This repair is covered under the New Vehicle Limited Warranty, in effect for four (4) years from the in-service date and 50K miles.

Karma Automotive bulletins and service documents are intended for use by experienced and trained Technicians. If you lack the skills, tools, equipment and a suitable workshop for any procedure described in this document, we suggest you leave such repairs to a Karma retailer and service provider. See your service provider for advice on whether your vehicle may benefit from the information contained within this document. The information contained in the Karma Bulletin is accurate at the date of publication. However, Karma Automotive regularly updates technical information. Please check with your Karma Automotive Retailer and Karma Automotive service provider that the bulletin you intend to use contains the latest available information.